

ACCU ELECTRIC MOTORS INC

USA: (888) 932-9183

CANADA: (905) 829-2505

- ✓ Over 100 years cumulative experience
- ✓ 24 hour rush turnaround / technical support service
- ✓ Established in 1993



The leading independent repairer of servo motors and drives in North America.

Visit us on the web:

www.servo-repair.com

www.servorepair.ca

www.ferrocontrol.com
www.sandvikrepair.com
www.accuelectric.com

Scroll down to view your document!

For 24/7 repair services :

USA: 1 (888) 932 - 9183

Canada: 1 (905) 829 -2505

Emergency After hours: 1 (416) 624 0386

Servicing USA and Canada

1326AS Series 460V, Low Inertia, Brushless Servo Motors



Product Data



This publication provides product information for the 0.49 to 49.3 N-m (4.33 to 436 lb-in.) 1326AS Series 460V, Low Inertia, Brushless Servo Motors. This publication includes:

- Detailed lists of the features and options available for 1326AS Series 460V, Low Inertia, Brushless Servo Motors
- Tables that show how to determine the catalog numbers for the motors and options you need
- Performance data and speed-torque curves for the entire 1326AS Series servo motor family
- Servo motor dimensions
- Details on holding brakes, shaft oil seal kits and junction boxes

Servo Motor Description

The 1326AS Series rare earth servo motors feature neodymium-iron-boron permanent magnet rotors that provide low inertias, high accelerations and high peak torques. These compact, environmentally-rugged, brushless, 460V servo motors are intended to be used with the Allen-Bradley 1394 Motion Control System. Each 1326AS Series servo motor features:

- An economical, compact design that can function in harsh environments.
- Neodymium-iron-boron magnet rotors that provide a high torque-to-inertia rating for faster light machinery acceleration.
- A three-phase, sinusoidally wound stator field for smooth operation at slow speeds.
- TENV construction. IP65 is standard.
- An extruded aluminum housing for improved heat transfer.
- A UL Listed insulation system (file #E149700).
- A CEI/IEC 72-1: 1991 metric flange mount with metric shafts.
- A normally closed thermal switch in the motor winding (maximum current rating of 2.5A at 250V AC) for thermal overload indication.
- A rugged, 2-pole brushless resolver that provides accurate position feedback, eliminates the need for on-board electronics and can withstand harsh shock, high operating temperatures and vibration. Resolver feedback generates 1024 ppr (4096 counts/rev) A Quad B encoder output.
- IP65 rated, quick release (bayonet release) connectors for easy installation and maintenance. IP67 is an option.
- The ability to be vertically mounted at any angle with the shaft up or down.
- Precision balance of 0.0127 mm (0.0005 in.) total peak-to-peak displacement.

Servo Motor Options

Options available for the 1326AS Series include (the option code or catalog number is in parenthesis):

- Integral spring-set holding brakes with 24V DC coils (-K3, -K4, -K6, and -K8).
- Shaft Oil Seal Kits for installing a Nitrile shaft seal in the field. Motor disassembly is not required. When the shaft seal is installed, the motor is dust tight, able to withstand pulsating water jets and meets the IP65 requirements of the IEC 529 standard.
- A field insatiable Junction Box Kit (1326AS-RJxx) that allows the existing motor connectors to be mounted axially (rather the radially) without further wiring is available with either front or rear exit connections.
- Right-angle connector cables (1326-xxx-RA-xxx, -RAL-xxx, -RB-xxx, and -RBL-xxx). Refer to the *1326 Cables for 460V AC Servo Motors Product Data* (publication 1326A-2.11) for cable options.

Figure 1
1326AS Series Servo Motor Options

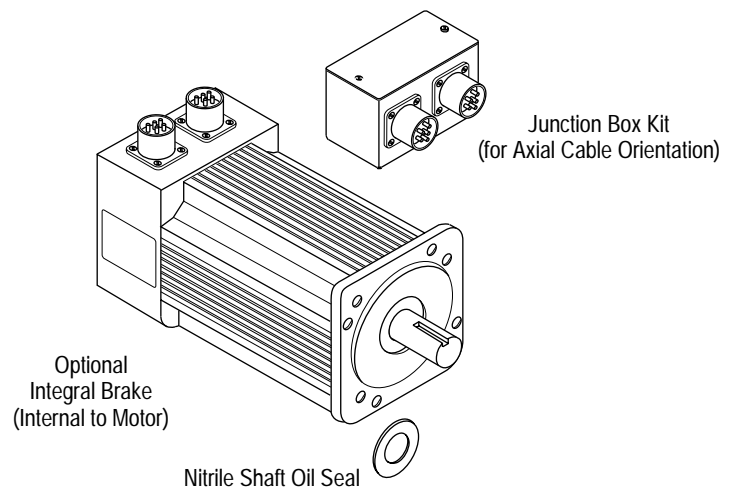

Servo Motor Cables

Servo motor cable information can be found at the end of this publication and in the *1326 Cables for 460V AC Servo Motors Product Data* (publication 1326A-2.11).

Motor Mounting Bolt Specifications

Refer to the following table to determine the correct bolt type to use with your motor.

Motor	Bolt Size	Pitch	Flange Thickness	Screw Length	Torque
B2xxx	M5	0.8 mm (0.031 in.)	12.3 mm (0.484 in.)	20 mm (0.787 in.)	3.36-6.72 N-m (30-60 in.-lb)
B3xxx	M6	1.00 mm (0.039 in.)	10.9 mm (0.429 in.)	20 mm (0.787 in.)	20.16-24.19 N-m (180-216 in.-lb)
B4xxx	M8	1.25 mm (0.049 in.)	11.2 mm (0.440 in.)	25 mm (0.984 in.)	37.63-47.04 N-m (336-420 in.-lb)
B6xxx	M12	1.75 mm (0.068 in.)	21.0 mm (0.826 in.)	40 mm (1.57 in.)	107.52-134.4 N-m (960-1200 in.-lb)
B8xxx	M12	1.75 mm (0.068 in.)	22.4 mm (0.881 in.)	40 mm (1.57 in.)	107.52-134.4 N-m (960-1200 in.-lb)

Determining Catalog Numbers

1326AS Series catalog numbers are made of various components. Each character of the catalog number identifies a specific version or option for that component. Use the selection tables below to assemble the catalog numbers for the motors and options you need.

1326AS Series Servo Motor

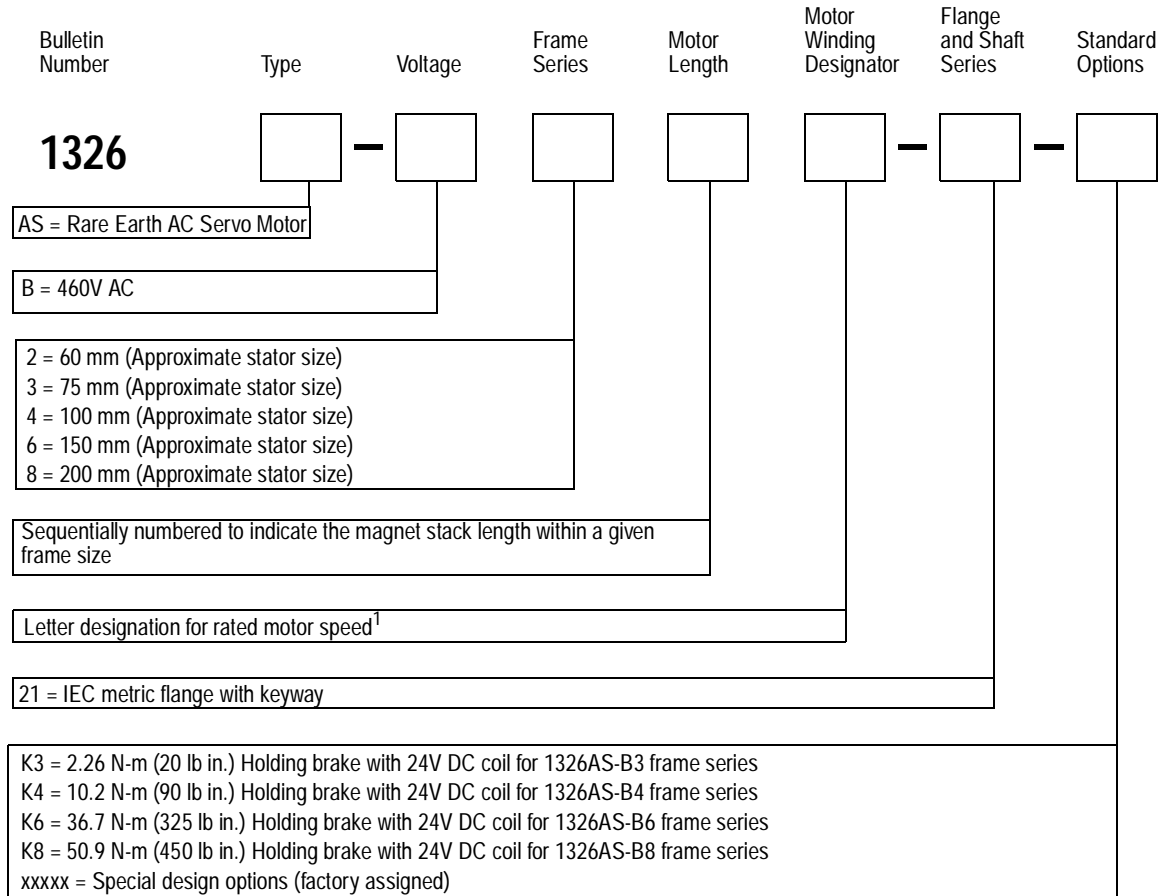

¹ See the table in the Servo Motor Performance Data section for the rated speeds of the entire 1326AS Series family of motors.

1326 Shaft Oil Seal Kit for 1326AS Motors

Bulletin
Number

Series

0041

—



5056=	Nitrile shaft seal for 1326AS-B2xx motors
5065 =	Nitrile shaft seal for 1326AS-B3xx motors
5066 =	Nitrile shaft seal for 1326AS-B4xx motors
5067 =	Nitrile shaft seal for 1326AS-B6xx motors
5053-005 =	Nitrile shaft seal for 1326AS-B8xx motors

Motor Junction Box Kit¹ for 1326AS Motors

Bulletin
Number

Type

1326AS

—



RJ34 =	Right angle junction box for B3 and B4 series motors.
--------	---

¹ The motor comes standard with IP65 plug style connectors mounted radially to the motor. This kit allows the connectors to be brought out axially to the motor without further wiring. Kit includes a motor junction box and mounting hardware.

Servo Motor Performance Data

This section contains 1326AS performance data. Included is a selection list detailing the performance data of selected amplifier/motor combinations, general speed-torque curve definitions and typical speed-torque curves.

Motor Catalog Number ¹	Rated Speed rpm		Motor Rated Torque N-m (lb-in.)	Motor Rated Output kW	Rotor Inertia kg-m ² (lb-in.-s ²)	System Continuous Torque N-m (lb-in.)	System Peak Stall Torque N-m (lb-in.)	System Continuous Stall Current Amperes	System Peak Stall Current Amperes	1394 Axis Module	
	460V	380V									
1326AS-B220H	5500	5000	0.49 (4.3)	0.17	0.00003 (0.0003)	0.49 (4.3)	1.24 (11.0)	0.57	1.7	AM03	
1326AS-B310H	6200	5120	0.7 (6.1)	0.3	0.000045 (0.0004)	0.7 (6.1)	2.1 (18)	0.8	2.4	AM03	
1326AS-B330H	6500	5370	2.0 (18.0)	0.9	0.00009 (0.0008)	2.1 (18)	5.6 (50)	2.1	6.0	AM03 AM04	
1326AS-B420G	5250	4340	3.2 (28.0)	1.2	0.0003 (0.0027)	3.2 (28)	7.3 (65) ³	2.6	6.0 ³	AM03	
							9.6 (84)		7.8	AM04	
										AM07	
1326AS-B440G	5250	4340	6.4 (56.0)	2.0	0.0005 (0.0046)	5.3 (47) ²	10.5 (93) ³	4.5 ²	9.0 ³	AM04	
						6.4 (56)	17.6 (156)		5.4	15.0	AM07
							19.0 (168)			16.2	AM50
1326AS-B460F	4300	3550	9.0 (80.0)	2.8	0.00075 (0.0066)	6.6 (58) ²	13.1 (116) ³	4.5 ²	9.0 ³	AM04	
						9.0 (80)	21.9 (194)		6.2	15.0	AM07
							27.1 (240)			18.6	AM50
1326AS-B630F	4500	3720	10.7 (95.0)	2.4	0.0014 (0.012)	10.3 (91) ²	20.6 (182) ³	7.5 ²	15.0 ³	AM07	
						10.7 (95)	25.4 (225)		7.8	18.5	AM50
1326AS-B660E	3000	2480	21.5 (190)	3.4	0.0025 (0.022)	13.7 (121) ²	27.3 (242) ³	7.5 ²	15.0 ³	AM07	
						21.5 (190)	54.2 (480)		11.8	29.8	AM50
							54.2 (480)			29.8	AM75
1326AS-B690E	3000	2480	36.4 (322)	5.0	0.0036 (0.032)	36.4 (322)	63.6 (563) ³	19.0	33.2 ³	AM50	
							79.1 (700)		41.3	AM75	
1326AS-B840E	3000	2480	37.6 (333)	4.7	0.0063 (0.056)	37.6 (333)	59.0 (522) ³	21.2	33.2 ³	AM50	
							70.0 (620)		39.5	AM75	
1326AS-B860C	2000	1650	49.3 (436)	6.0	0.0094 (0.083)	49.3 (436)	93.0 (823) ³	17.6	33.2 ³	AM50	
							124.0 (1100)		44.4	AM75	

¹ All ratings are for 40° C (104° F) motor ambient, 100° C (212° F) case and 50° C (122° F) amplifier ambient. For extended ratings at lower ambient temperatures, contact Allen-Bradley.

² Limited by the axis module continuous current.

³ Limited by axis module peak current.

General Speed-Torque Curve Definitions

The typical speed-torque curves show the operational envelope of different 1326AS Series/1394 combinations. General definitions for the 1326AS Series servo motors are given starting below.

Rated Speed - The operating speed of the drive and motor combination at which approximately 70% of continuous rated torque (T_o) can be developed. This point is defined with the motor at 25° C (77° F).

Rated Operation Area - The boundary of the speed-torque curve where the motor and controller combination may operate on a servo basis without exceeding the RMS rating of either.

Intermittent Operation Area - The boundary of the speed-torque curve where the motor and controller combination may operate in acceleration/deceleration mode without exceeding peak rating of either, provided that the duty cycle RMS continuous torque limit is not exceeded.

$$\text{RMSTorque} = \sqrt{\frac{(T_{pa}^2)(t_1) + (T_{ss}^2)(t_2) + (T_{pd}^2)(t_3) + (T_r^2)(t_4)}{t_1 + t_2 + t_3 + t_4}}$$

Continuous Current - The rated current of a motor with windings at a rated temperature and an ambient temperature of 40° C (104° F).

Peak Current - The amount of current that can be applied to the motor without causing damage to the motor.

Mechanical Time Constant - The time required for the motor to reach 63% of its final speed when a step voltage is applied.

Electrical Time Constant - The time required for the motor to reach 63% of its rated current.

Max. Ambient Temperature - The maximum environmental temperature in which the motor can be operated at rated loads without exceeding its insulation-type temperature rise limits.

Insulation Class - The designation of the operating temperature limits for motor insulation materials.

Thermal Time Constant - The time required for the motor windings to reach 63% of continuous temperature rise with constant watts loss.

Torque Constant - The amount of torque developed for one ampere of motor current at the stated motor temperature.

Voltage Constant - The value of the generated voltage at a specified speed when the rotor is moved mechanically in the magnetic field.

Terminal Resistance - The winding resistance.

Inductance - The winding inductance measured by a step input of zero impedance voltage applied to the locked rotor.

Rotor Polar Moment of Inertia - The moment of inertia about the axis of rotation.

Motor Weight - The weight of the complete motor (including brake, if supplied) less the weight of options.

Balance - The compensation of rotor weight distribution to reduce vibrational resonance. Motors are factory balanced under running speeds.

Figure 2
1326AS-B220H and 1326AS-B310H Speed-Torque Curves

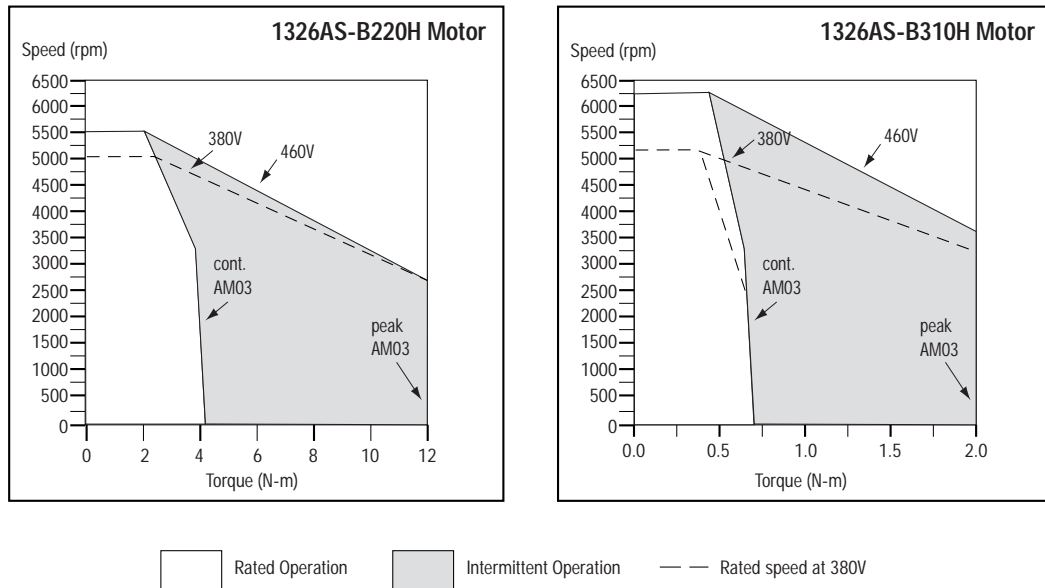

Important: The Servo Motor Performance Data section provides system ratings for specific motor/amplifier combinations.

The motor was tested at a line voltage of 460V AC, in an environment where the ambient temperature was 40° C (104° F). The case temperature was approximately 100° C (212° F) with the motor windings at an 85° C (185° F) rise over ambient. Torque ratings were determined when the motor was mounted to a 304.8 mm x 304.8 mm x 25.4 mm (12 in. x 12 in. x 1 in.) steel mounting bracket. The motor contains a normally closed thermal switch that opens when the internal motor temperature reaches 140° C (284° F) ± 5° C (± 9° F). The thermal switch has a maximum current rating of 2.5A at 250V AC. All values shown below have a tolerance of ± 10%.

Category	Parameter	Ambient Temperature	Units	1326AS-B220H	1326AS-B310H
General	Continuous Stall Torque - AM03/04	at 40° C (104° F)	N-m (lb-in.)	0.49 (4.3)/NA	0.7 (6)/NA
	Rated Output		kW	0.17	0.3
	Peak Stall Torque - AM03/04	at 40° C (104° F)	N-m (lb-in.)	1.24 (11.)/NA	2.1 (18)/NA
	Continuous Stall Current - AM03/04	at 40° C (104° F)	amperes	0.57/NA	0.8/NA
	Peak Stall Current - AM03/04	at 40° C (104° F)	amperes	1.7/NA	2.4/NA
	Mechanical Time Constant	at 40° C (104° F)	milliseconds	5.2	3.3
	Electrical Time Constant	at 40° C (104° F)	milliseconds	0.91	1.4
	Rated Speed - 460V/380V	at 40° C (104° F)	rpm	5500/5000	6200/5120
Thermal	Maximum Ambient Temperature (without derating)		degrees C	40	40
	Insulation Class			B	B
	Thermal Time Constant		minutes	11	11
Winding	Torque Constant	at 25° C (77° F)	N-m (lb-in.)/A	1.04 (9.2)	1.04 (9.2)
	Voltage Constant	RMS (L-L) at 25° C (77° F)	volts/1000 rpm	63	63
	Terminal Resistance	ohms (L-L) at 25° C (77° F)	ohms	110	52.4
	Inductance	mH (L-L) at 25° C (77° F)	millihenry	100	72.0
Mechanical	Rotor Polar Moment of Inertia		kg-m ² (lb-in.-s ²)	0.000033 (0.0003)	0.000045 (0.0004)
	Motor Weight		kg (lb)	2.2 (4.8)	2.8 (6.2)
	Balance ¹		mm (in.)	0.0127 (0.0005)	0.0127 (0.0005)

¹ To obtain vibration velocity in inches (mm)/second, use the following formula: $V_v = D_{p-p} \times \text{rpm}/27.01$
 where:
 V_v = Vibration velocity in mm (in.)/second
 D_{p-p} = Peak-peak displacement in mm (in.)
 rpm = Motor speed

Figure 3
1326AS-B330H and 1326AS-B420G Speed-Torque Curves

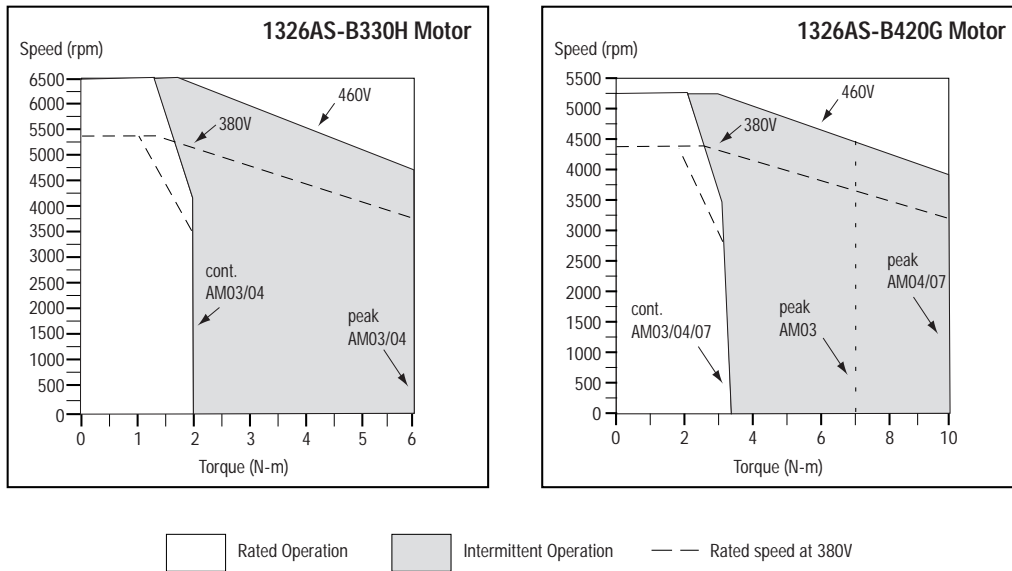

Important: The Servo Motor Performance Data section provides system ratings for specific motor/amplifier combinations. The motor was tested at a line voltage of 460V AC, in an environment where the ambient temperature was 40° C (104° F). The case temperature was approximately 100° C (212° F) with the motor windings at an 85° C (185° F) rise over ambient. Torque ratings were determined when the motor was mounted to a 304.8 mm x 304.8 mm x 25.4 mm (12 in. x 12 in. x 1 in.) steel mounting bracket. The motor contains a normally closed thermal switch that opens when the internal motor temperature reaches 140° C (284° F) ± 5° C (± 9° F). The thermal switch has a maximum current rating of 2.5A at 250V AC. All values shown below have a tolerance of ± 10%.

Category	Parameter	Ambient Temperature	Units	1326AS-B330H	1326AS-B420G
General	Continuous Stall Torque - AM03/04/07	at 40° C (104° F)	N-m (lb-in.)	2.1 (18)/2.1 (18)/NA	3.2 (28)/3.2 (28)/3.2 (28)
	Rated Output		kW	0.9	1.2
	Peak Stall Torque - AM03/04/07	at 40° C (104° F)	N-m (lb-in.)	5.6 (50)/5.6 (50)/NA	7.3 (65)/9.6 (84)/9.6 (84)
	Continuous Stall Current - AM03/04/07	at 40° C (104° F)	amperes	2.1/2.1/NA	2.6/2.6/2.6
	Peak Stall Current - AM03/04/07	at 40° C (104° F)	amperes	6.0/6.0/NA	6.0/7.8/7.8
	Mechanical Time Constant	at 40° C (104° F)	milliseconds	1.3	2.0
	Electrical Time Constant	at 40° C (104° F)	milliseconds	2.4	3.9
	Rated Speed - 460V/380V	at 40° C (104° F)	rpm	6500/5370	5250/4340
Thermal	Maximum Ambient Temperature (without derating)		degrees C	40	40
	Insulation Class			B	B
	Thermal Time Constant		minutes	21	18
Winding	Torque Constant	at 25° C (77° F)	N-m (lb-in.)/A	1.04 (9.2)	1.25 (11.1)
	Voltage Constant	RMS (L-L) at 25° C (77° F)	volts/1000 rpm	63	76
	Terminal Resistance	ohms (L-L) at 25° C (77° F)	ohms	10.2	6.9
	Inductance	mH (L-L) at 25° C (77° F)	millihenry	24.0	27.0
Mechanical	Rotor Polar Moment of Inertia		kg-m ² (lb-in.-s ²)	0.00009 (0.0008)	0.0003 (0.0027)
	Motor Weight		kg (lb)	4.3 (9.4)	8.1 (17.86)
	Balance ¹		mm (in.)	0.0127 (0.0005)	0.0127 (0.0005)

¹ To obtain vibration velocity in inches (mm)/second, use the following formula: $V_v = D_{p-p} \times \text{rpm} / 27.01$
 where:
 V_v = Vibration velocity in mm (in.)/second
 D_{p-p} = Peak-peak displacement in mm (in.)
 rpm = Motor speed

Figure 4
1326AS-B440G and 1326AS-B460F Speed-Torque Curves

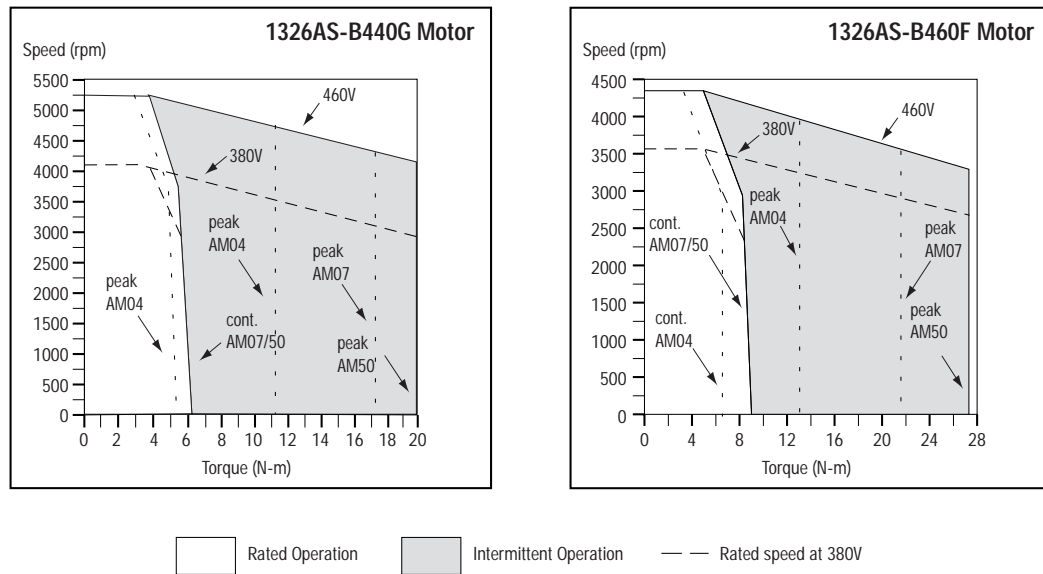

Important: The Servo Motor Performance Data section provides system ratings for specific motor/amplifier combinations.

The motor was tested at a line voltage of 460V AC, in an environment where the ambient temperature was 40° C (104° F). The case temperature was approximately 100° C (212° F) with the motor windings at an 85° C (185° F) rise over ambient. Torque ratings were determined when the motor was mounted to a 304.8 mm x 304.8 mm x 25.4 mm (12 in. x 12 in. x 1 in.) steel mounting bracket. The motor contains a normally closed thermal switch that opens when the internal motor temperature reaches 140° C (284° F) ± 5° C (± 9° F). The thermal switch has a maximum current rating of 2.5A at 250V AC. All values shown below have a tolerance of ± 10%.

Category	Parameter	Ambient Temperature	Units	1326AS-B440G	1326AS-B460F
General	Continuous Stall Torque - AM04/07/50	at 40° C (104° F)	N-m (lb-in.)	5.3 (47)/6.4 (56)/6.4 (56)	6.6 (58)/9.0 (80)/9.0 (80)
	Rated Output		kW	2.0	2.8
	Peak Stall Torque - AM04/07/50	at 40° C (104° F)	N-m (lb-in.)	10.6 (94)/17.6 (156)/19.0 (168)	13.1 (116)/21.9 (194)/27.1 (240)
	Continuous Stall Current- AM04/07/50	at 40° C (104° F)	amperes	4.5/5.4/5.4	4.5/6.2/6.2
	Peak Stall Current - AM04/07/50	at 40° C (104° F)	amperes	9.0/15.0/16.2	9.0/15.0/18.6
	Mechanical Time Constant	at 40° C (104° F)	milliseconds	1.3	0.98
	Electrical Time Constant	at 40° C (104° F)	milliseconds	4.0	5.5
	Rated Speed - 460V/380V	at 40° C (104° F)	rpm	5250/4340	4300/3550
Thermal	Maximum Ambient Temperature (without derating)		degrees C	40	40
	Insulation Class			B	B
	Thermal Time Constant		minutes	35	41
Winding	Torque Constant	at 25° C (77° F)	N-m (lb-in.)/A	1.25 (11.1)	1.58 (14.0)
	Voltage Constant	RMS (L-L) at 25° C (77° F)	volts/1000 rpm	76	96
	Terminal Resistance	ohms (L-L) at 25° C (77° F)	ohms	2.5	2.2
	Inductance	mH (L-L) at 25° C (77° F)	millihenry	10.0	12.0
Mechanical	Rotor Polar Moment of Inertia		kg-m ² (lb-in.-s ²)	0.0005 (0.0046)	0.00075 (0.0066)
	Motor Weight		kg (lb)	11.7 (25.79)	13.8 (30.4)
	Balance ¹		mm (in.)	0.0127 (0.0005)	0.0127 (0.0005)

¹ To obtain vibration velocity in inches (mm)/second, use the following formula: $V_v = D_{p-p} \times \text{rpm} / 27.01$
 where:
 V_v = Vibration velocity in mm (in.)/second
 D_{p-p} = Peak-peak displacement in mm (in.)
 rpm = Motor speed

Figure 5
1326AS-B630F and 1326AS-B660E Speed-Torque Curves

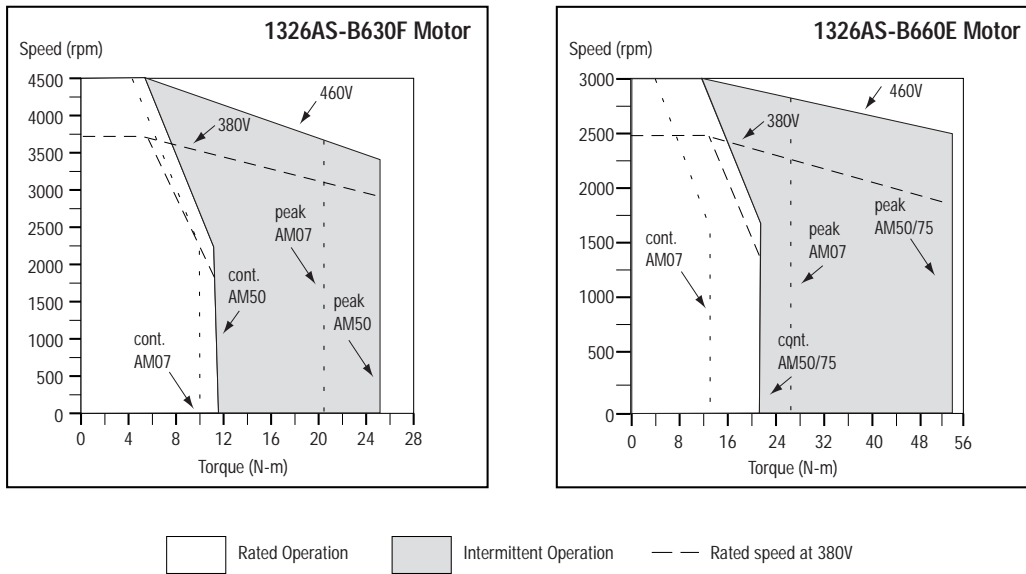

Important: The Servo Motor Performance Data section provides system ratings for specific motor/amplifier combinations.

The motor was tested at a line voltage of 460V AC, in an environment where the ambient temperature was 40° C (104° F). The case temperature was approximately 100° C (212° F) with the motor windings at an 85° C (185° F) rise over ambient. Torque ratings were determined when the motor was mounted to a 304.8 mm x 304.8 mm x 25.4 mm (12 in. x 12 in. x 1 in.) steel mounting bracket. The motor contains a normally closed thermal switch that opens when the internal motor temperature reaches 140° C (284° F) ± 5° C (± 9° F). The thermal switch has a maximum current rating of 2.5A at 250V AC. All values shown below have a tolerance of ± 10%.

Category	Parameter	Ambient Temperature	Units	1326AS-B630F	1326AS-B660E
General	Continuous Stall Torque-AM07/50/75	at 40° C (104° F)	N-m (lb-in.)	NA/10.3 (91)/ 10.7 (95)/NA	13.7 (121)/21.5 (190)/ 21.5 (190)
	Rated Output		kW	2.4	3.4
	Peak Stall Torque-AM07/50/75	at 40° C (104° F)	N-m (lb-in.)	NA/20.6 (182)/ 25.4 (225)/NA	27.3 (242)/54.2 (480)/ 54.2 (480)
	Continuous Stall Current AM07/50/75	at 40° C (104° F)	amperes	NA/7.5/7.8/NA	7.5/11.8/11.8
	Peak Stall Current-AM07/50/75	at 40° C (104° F)	amperes	NA/15.0/18.5/NA	15.0/29.8/29.8
	Mechanical Time Constant	at 40° C (104° F)	milliseconds	0.89	0.65
	Electrical Time Constant	at 40° C (104° F)	milliseconds	8.7	11.3
	Rated Speed - 460V/380V	at 40° C (104° F)	rpm	4500/3720	3000/2480
Thermal	Maximum Ambient Temperature (without derating)		degrees C	40	40
	Insulation Class			B	B
	Thermal Time Constant		minutes	50	60
Winding	Torque Constant	at 25° C (77° F)	N-m (lb-in.)/A	1.58 (14.0)	2.09 (18.5)
	Voltage Constant	RMS (L-L) at 25° C (77° F)	volts/1000 rpm	96	127
	Terminal Resistance	ohms (L-L) at 25° C (77° F)	ohms	1.1	0.76
	Inductance	mH (L-L) at 25° C (77° F)	millihenry	9.5	8.6
Mechanical	Rotor Polar Moment of Inertia		kg-m ² (lb-in.-s ²)	0.0014 (0.012)	0.0025 (0.022)
	Motor Weight		kg (lb)	18.3 (40.4)	26.9 (59.4)
	Balance ¹		mm (in.)	0.0178 (0.0007)	0.0178 (0.0007)

¹ To obtain vibration velocity in inches (mm)/second, use the following formula: $V_v = D_{p-p} \times \text{rpm} / 27.01$
 where:
 V_v = Vibration velocity in mm (in.)/second
 D_{p-p} = Peak-peak displacement in mm (in.)
 rpm = Motor speed

Figure 6
1326AS-B690E and 1326AS-B840E Speed-Torque Curves

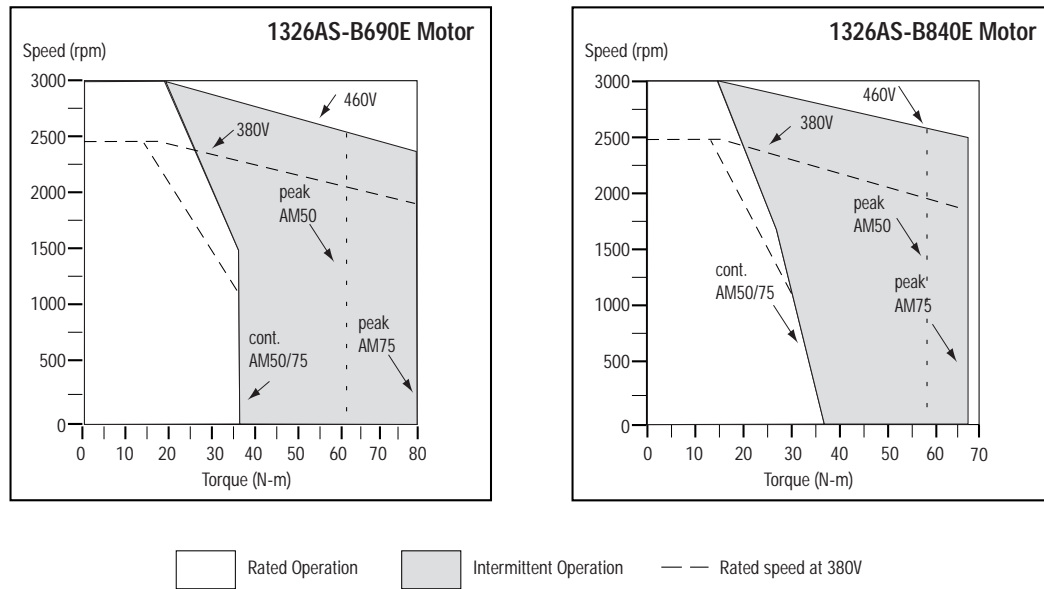

Important: The Servo Motor Performance section provides system ratings for specific motor/amplifier combinations.

The motor was tested at a line voltage of 460V AC, in an environment where the ambient temperature was 40° C (104° F). The case temperature was approximately 100° C (212° F) with the motor windings at an 85° C (185° F) rise over ambient. Torque ratings were determined when the motor was mounted to a 304.8 mm x 304.8 mm x 25.4 mm (12 in. x 12 in. x 1 in.) steel mounting bracket. The motor contains a normally closed thermal switch that opens when the internal motor temperature reaches 140° C (284° F) ± 5° C (± 9° F). The thermal switch has a maximum current rating of 2.5A at 250V AC. All values shown below have a tolerance of ± 10%.

Category	Parameter	Ambient Temperature	Units	1326AS-B690E	1326AS-B840E
General	Continuous Stall Torque-AM50/75	at 40° C (104° F)	N-m (lb-in.)	36.4 (322)/36.4 (322)	37.6 (333)/37.6 (333)
	Rated Output		kW	5.0	4.7
	Peak Stall Torque-AM50/75	at 40° C (104° F)	N-m (lb-in.)	63.6 (563)/79.1 (700)	59.0 (522)/70.0 (620)
	Continuous Stall Current-AM50/75	at 40° C (104° F)	amperes	19.0/19.0	21.2/21.2
	Peak Stall Current-AM50/75	at 40° C (104° F)	amperes	33.2/41.3	33.2/39.5
	Mechanical Time Constant	at 40° C (104° F)	milliseconds	0.65	0.85
	Electrical Time Constant	at 40° C (104° F)	milliseconds	10.4	20.9
	Rated Speed - 460V/380V	at 40° C (104° F)	rpm	3000/2480	3000/2480
Thermal	Maximum Ambient Temperature (without derating)		degrees C	40	40
	Insulation Class			B	B
	Thermal Time Constant		minutes	90	74
Winding	Torque Constant	at 25° C (77° F)	N-m (lb-in.)/A	2.16 (19.1)	1.94 (17.2)
	Voltage Constant	RMS (L-L) at 25° C (77° F)	volts/1000 rpm	131	118
	Terminal Resistance	ohms (L-L) at 25° C (77° F)	ohms	0.56	0.34
	Inductance	mH (L-L) at 25° C (77° F)	millihenry	5.8	7.1
Mechanical	Rotor Polar Moment of Inertia		kg·m ² (lb-in.·s ²)	0.0036 (0.032)	0.0063 (0.056)
	Motor Weight		kg (lb)	34.8 (76.8)	46.7 (103.0)
	Balance ¹		mm (in.)	0.0178 (0.0007)	0.0178 (0.0007)

¹ To obtain vibration velocity in inches (mm)/second, use the following formula: $V_v = D_{p-p} \times \text{rpm} / 27.01$
 where:
 V_v = Vibration velocity in mm (in.)/second
 D_{p-p} = Peak-peak displacement in mm (in.)
 rpm = Motor speed

Figure 7
1326AS-B860C Speed-Torque Curve

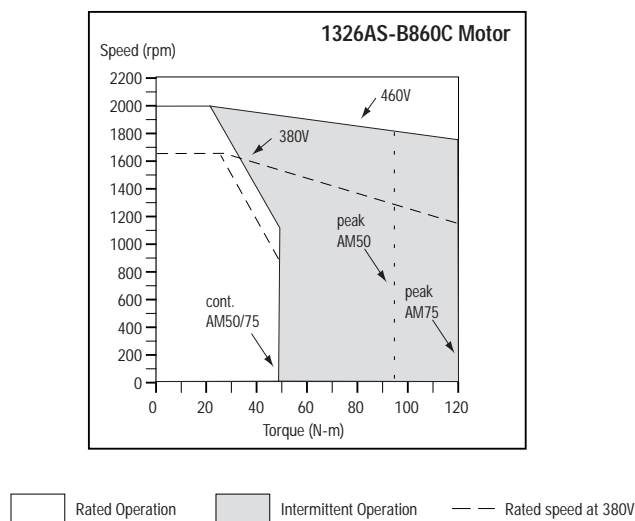

Important: The Servo Motor Performance Data section provides system ratings for specific motor/amplifier combinations.

The motor was tested at a line voltage of 460V AC, in an environment where the ambient temperature was 40° C (104° F). The case temperature was approximately 100° C (212° F) with the motor windings at an 85° C (185° F) rise over ambient. Torque ratings were determined when the motor was mounted to a 304.8 mm x 304.8 mm x 25.4 mm (12 in. x 12 in. x 1 in.) steel mounting bracket. The motor contains a normally closed thermal switch that opens when the internal motor temperature reaches 140° C (284° F) ± 5° C (± 9° F). The thermal switch has a maximum current rating of 2.5A at 250V AC. All values shown below have a tolerance of ± 10%.

Category	Parameter	Ambient Temperature	Units	1326AS-B860C
General	Continuous Stall Torque-AM50/75	at 40° C (104° F)	N-m (lb-in.)	49.3 (436)/49.3 (436)
	Rated Output		kW	6.0
	Peak Stall Torque-AM50/75	at 40° C (104° F)	N-m (lb-in.)	93.0 (823)/124.0 (1100)
	Continuous Stall Current-AM50/75	at 40° C (104° F)	amperes	17.6/17.6
	Peak Stall Current-AM50/75	at 40° C (104° F)	amperes	33.2/44.4
	Mechanical Time Constant	at 40° C (104° F)	milliseconds	0.76
	Electrical Time Constant	at 40° C (104° F)	milliseconds	23.1
	Rated Speed - 460V/380V	at 40° C (104° F)	rpm	2000/1650
Thermal	Maximum Ambient Temperature (without derating)		degrees C	40
	Insulation Class			B
	Thermal Time Constant		minutes	80
Winding	Torque Constant	at 25° C (77° F)	N-m (lb-in.)/A	3.10 (27.4)
	Voltage Constant	RMS (L-L) at 25° C (77° F)	volts/1000 rpm	188
	Terminal Resistance	ohms (L-L) at 25° C (77° F)	ohms	0.52
	Inductance	mH (L-L) at 25° C (77° F)	millihenry	12
Mechanical	Rotor Polar Moment of Inertia		kg-m ² (lb-in.-s ²)	0.0094 (0.083)
	Motor Weight		kg (lb)	56.1 (123.6)
	Balance ¹		mm (in.)	0.0178 (0.0007)

¹ To obtain vibration velocity in inches (mm)/second, use the following formula: $V_v = D_{p-p} \times \text{rpm} / 27.01$
 where:
 V_v = Vibration velocity in mm (in.)/second
 D_{p-p} = Peak-peak displacement in mm (in.)
 rpm = Motor speed

Servo Motor Dimensions

The following figures provide approximate dimensions for the 1326AS Series servo motors.

Figure 8
Motor Dimensions - 1326AS-B2 Series Servo Motor

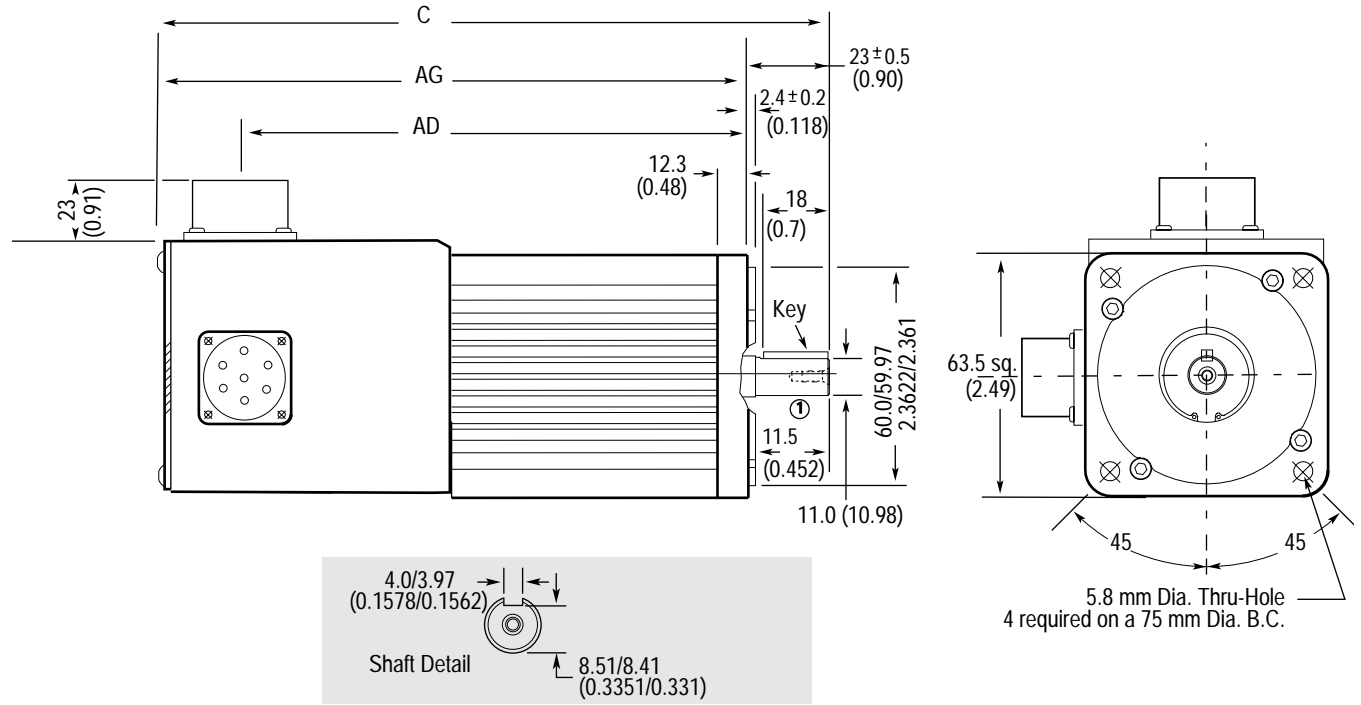

① Shaft and Pilot Tolerances

Shaft Runout	0.025 (0.001) T.I.R.
Shaft Endplay	0.025 (0.001)
Pilot Eccentricity	0.08 (0.0032) T.I.R.
Maximum Face Runout	0.08 (0.0032) T.I.R.

Motor Name Plate

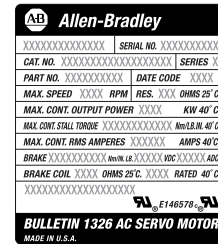

Flange Mount in millimeters and (inches)						
Catalog number	Description	AD	AG	C	Key	End milled keyway (full depth)
1326AS-B220x	without brake ¹	190 (7.48)	218 (8.58)	241 (9.48)	4 x 4x 18 (0.157 x 0.157 x 0.708)	18 (0.708)

¹ A brake is not available for the the 1326AS-B2 motor.

Dimensions are per NEMA Standards MG 7-2.4.1.3 and IEC 72-1. Shaft and pilot tolerances are per DIN 42955, N tolerance.

Figure 9
Motor Dimensions - 1326AS-B3 Series Servo Motor

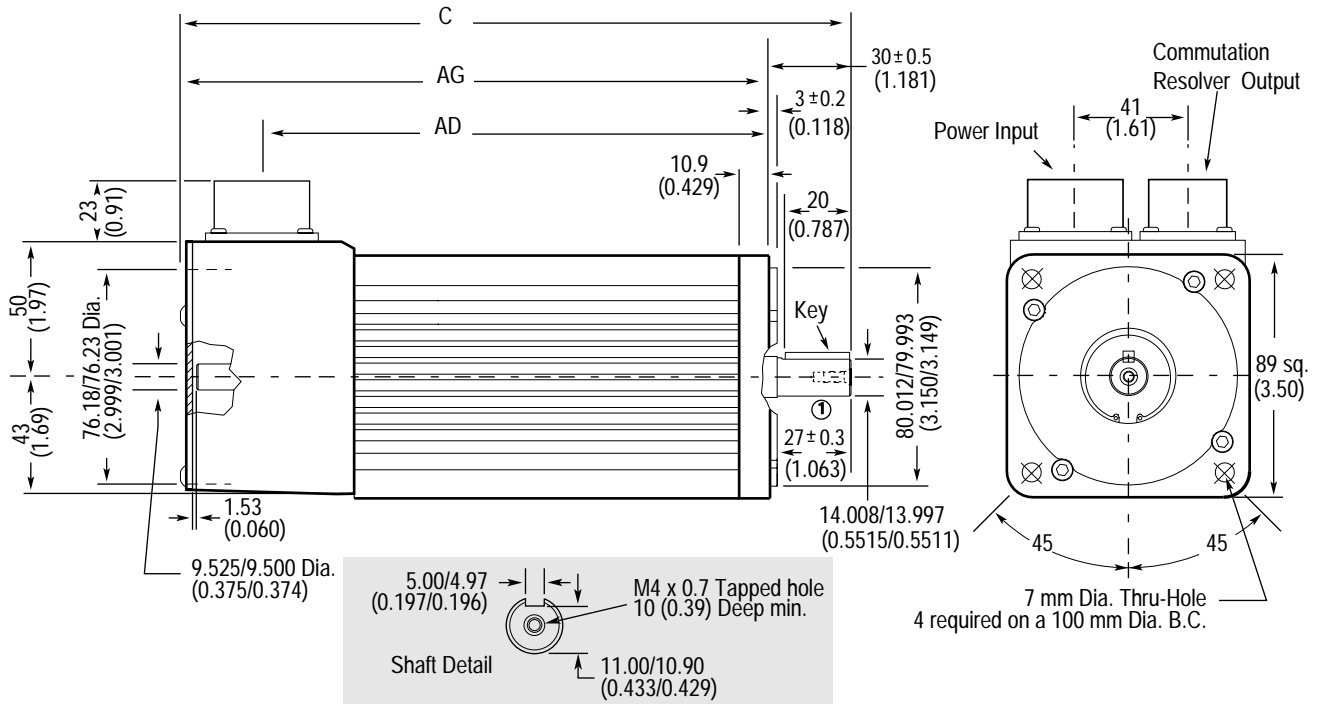

Ⓞ Shaft and Pilot Tolerances

Shaft Runout	0.025 (0.001) T.I.R
Shaft Endplay	0.025 (0.001)
Pilot Eccentricity	0.08 (0.0032) T.I.R
Maximum Face Runout	0.08 (0.0032) T.I.R

Motor Name Plate

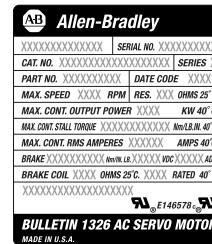

Flange Mount in millimeters and (inches)						
Catalog number	Description	AD	AG	C	Key	End milled keyway (full depth)
1326AS-B310x-21	without brake ¹	135 (5.32)	165 (6.50)	195 (7.68)	5 x 5 x 20 (0.197 x 0.197 x 0.79)	20 (0.79)
1326AS-B330x-21	without brake ¹	186 (7.32)	216 (8.50)	246 (9.68)	5 x 5 x 20 (0.197 x 0.197 x 0.79)	20 (0.79)

¹ If you are ordering a 1326AS-B3xxx-21-K3 with an optional 24V DC 2.26 N-m (20 lb-in.) brake, add 39 mm (1.54 in.) to AD, AG and C. Dimensions are per NEMA Standards MG 7-2.4.1.3 and IEC 72-1. Shaft and pilot tolerances are per DIN 42955, N tolerance.

Figure 10
Motor Dimensions - 1326AS-B4 Series Servo Motor

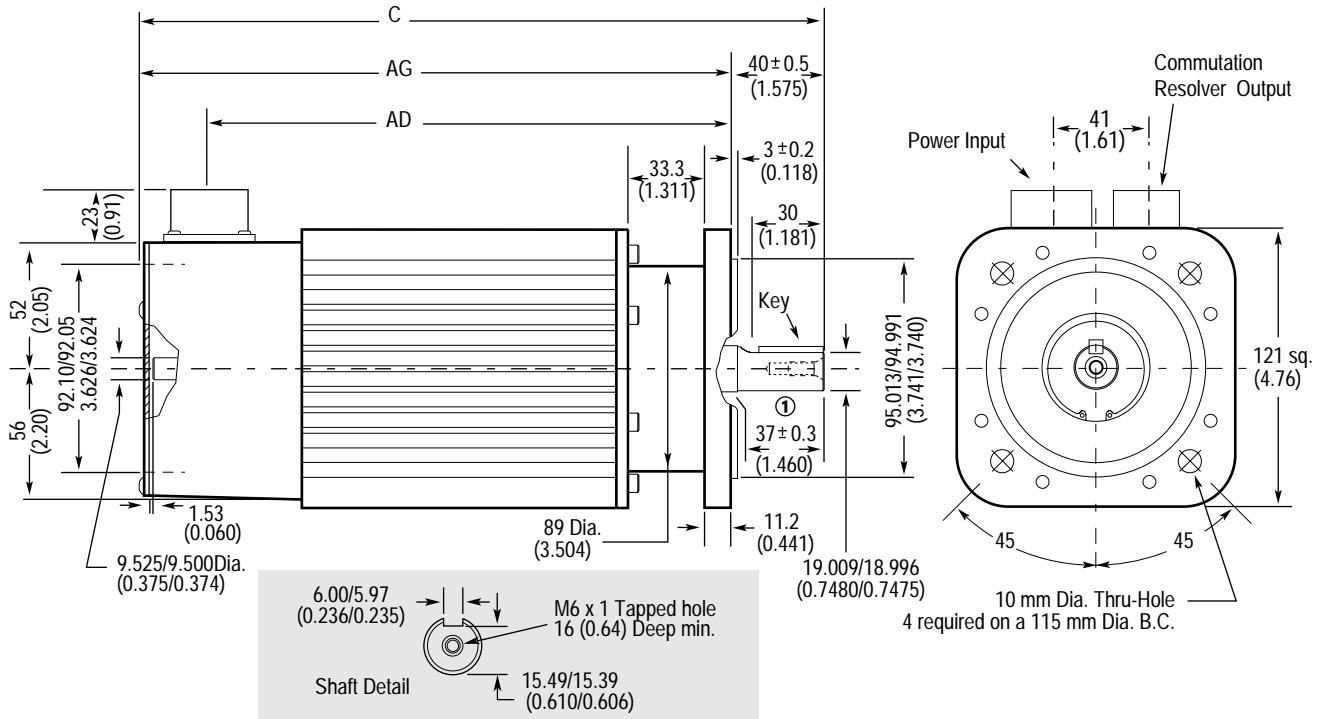

Ⓞ Shaft and Pilot Tolerances

Shaft Runout	0.04 (0.0016) T.I.R
Shaft Endplay	0.025 (0.001)
Pilot Eccentricity	0.08 (0.0032) T.I.R
Maximum Face Runout	0.08 (0.0032) T.I.R

Motor Name Plate



Flange Mount in millimeters and (inches)						
Catalog number	Description	AD	AG	C	Key	End milled keyway (full depth)
1326AS-B420x-21	without brake ¹	208 (8.19)	238 (9.38)	278 (10.95)	6 x 6 x 30 (0.236 x 0.236 x 1.18)	30.0 (1.18)
1326AS-B440x-21	without brake ¹	259 (10.19)	289 (11.38)	329 (12.95)	6 x 6 x 30 (0.236 x 0.236 x 1.18)	30.0 (1.18)
1326AS-B460x-21	without brake ¹	310 (12.19)	340 (13.38)	380 (14.95)	6 x 6 x 30 (0.236 x 0.236 x 1.18)	30.0 (1.18)

¹ If you are ordering a 1326AS-B4xxx-21-K4 with an optional 24V DC 10.2 N-m (90 lb-in.) brake, add 46 mm (1.81 in.) to AD, AG and C. Dimensions are per NEMA Standards MG 7-2.4.1.3 and IEC 72-1. Shaft and pilot tolerances are per DIN 42955, N tolerance.

Figure 11
Motor Dimensions - 1326AS-B6 Series Servo Motor

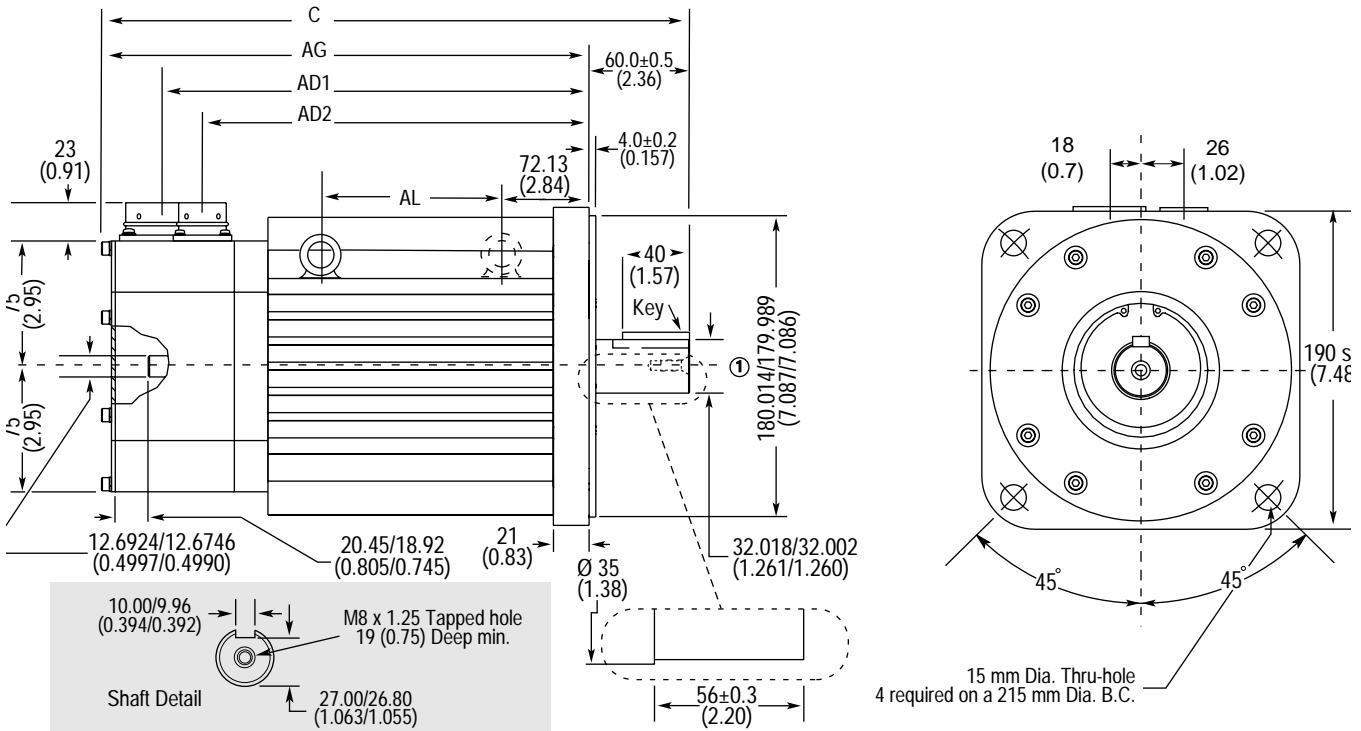

① Shaft and Pilot Tolerances

Shaft Runout	0.05 (0.002) T.I.R
Shaft Endplay	0.025 (0.001)
Pilot Eccentricity	0.10 (0.004) T.I.R
Maximum Face Runout	0.10 (0.004) T.I.R

Motor Name Plate



Flange Mount in millimeters and (inches)								
Catalog number	Description	AL	AD1	AD2	AG	C	Key	End milled keyway (full depth)
1326AS-B630x-21	without brake ¹	69 (2.71)	255 (10.03)	231 (9.09)	291 (11.45)	351 (13.81)	10 x 8 x 40 (0.394 x 0.315 x 1.57)	40 (1.57)
1326AS-B660x-21	without brake ¹	145 (5.71)	331 (13.03)	307 (12.09)	367 (14.45)	427 (16.81)	10 x 8 x 40 (0.394 x 0.315 x 1.57)	40 (1.57)
1326AS-B690x-21	without brake ¹	221 (8.71)	407 (16.03)	383 (15.09)	443 (17.45)	503 (19.81)	10 x 8 x 40 (0.394 x 0.315 x 1.57)	40 (1.57)

¹ If you are ordering a 1326AS-B6xxx-21-K6 with an optional 24V DC 36.7 N-m (325 lb-in.) brake, add 54 mm (2.13 in.) to AL, AD1, AD2, AG and C. Dimensions are per NEMA Standards MG 7-2.4.1.3 and IEC 72-1. Shaft and pilot tolerances are per DIN 42955, N tolerance. The eye bolt diameter is 30.48 mm (1.20 in) O.D. x 19.05 mm (0.75 in) I.D.

Figure 12
Motor Dimensions - 1326AS-B8 Series Servo Motor

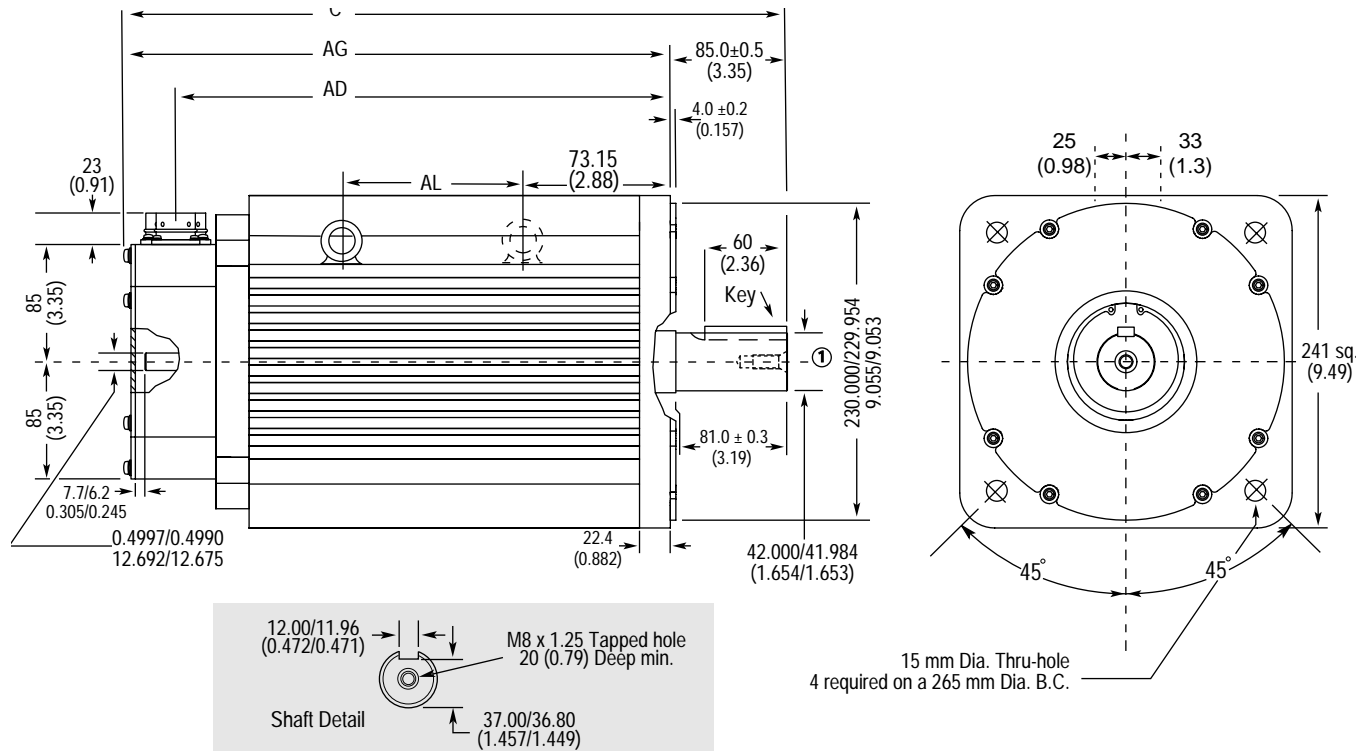

⊙ Shaft and Pilot Tolerances

Shaft Runout	0.05 (0.002) T.I.R
Shaft Endplay	0.025 (0.001)
Pilot Eccentricity	0.10 (0.004) T.I.R
Maximum Face Runout	0.10 (0.004) T.I.R

Motor Name Plate

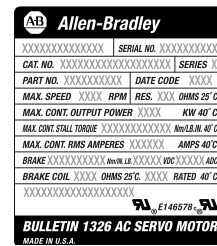

Flange Mount in millimeters and (inches)							
Catalog number	Description	AL	AD	AG	C	Key	End milled keyway (full depth)
1326AS-B840x-21	without brake ¹	131 (5.15)	308 (12.13)	346 (13.63)	431 (16.97)	12 x 8 x 60 (0.472 x 0.315 x 2.36)	60 (2.36)
1326AS-B860x-21	without brake ¹	235 (9.25)	359 (14.13)	397 (15.63)	482 (18.97)	12 x 8 x 60 (0.472 x 0.315 x 2.36)	60 (2.36)

¹ If you are ordering a 1326AS-B8xxx-21-K8 with an optional 24V DC 50.9 N-m (450lb-in.) brake, add 103 mm (4.05 in.) to AD, AG and C. Add 51 mm (2.0 in) to AL. Dimensions are per NEMA Standards MG 7-2.4.1.3 and IEC 72-1. Shaft and pilot tolerances are per DIN 42955, N tolerance. The eye bolt diameter is 38.1 mm (1.50 in) O.D. x 22.35 mm (0.88 in) I.D.

Figure 13
Motor Output Shaft Radial Load vs. Thrust Load

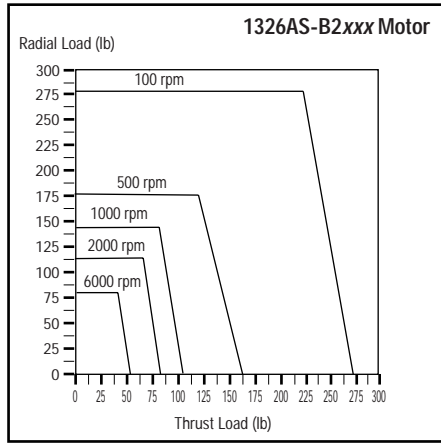

x = 10.31 mm (0.41 in.)

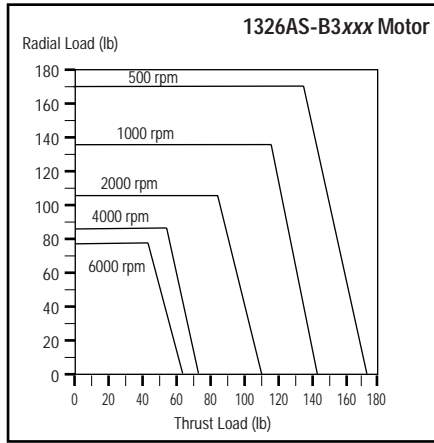

x = 13.5 mm (0.53 in.)

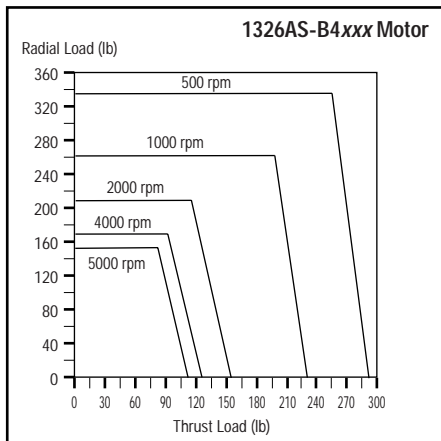

x = 18.5 mm (0.73 in.)

1326AS AC Servomotor 15,000 hour B10 bearing life -
 vertical or horizontal mounting

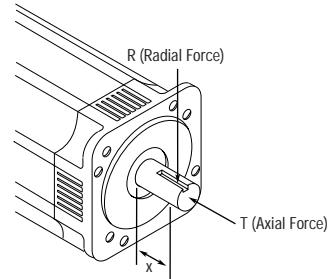
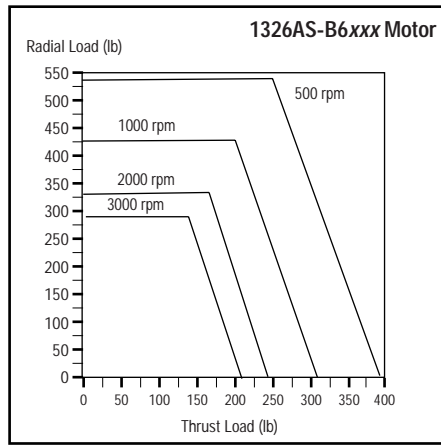
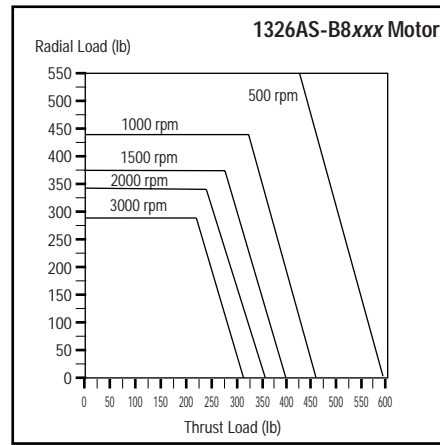

Figure 14
Motor Output Shaft Radial Load vs. Thrust Load



x = 28 mm (1.10 in.)



x = 41 mm (1.61 in.)

1326AS AC Servomotor 15,000 hour B10 bearing life -
 vertical or horizontal mounting

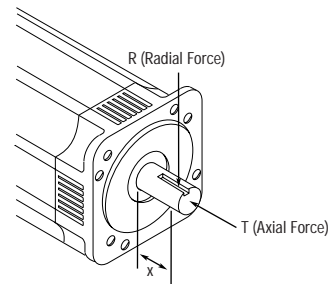

Servo Motor Options

This section provides detailed information on the various options available for the 1326AS Series servo motors.

Integral Holding Brake

The disc-type brake is spring-set upon removal of power. It is designed to hold a load at rest and provide limited braking torque for emergency stopping. The brake is not intended to be used as a positioning brake or continuously cycled to assist in stopping a load. The brake must not be energized/de-energized more than 90 times an hour when used as a parking brake. A parking brake is only meant to hold a stationary load and is not intended to stop motor movement unless a power interruption occurs. For further information, refer to the table below.

Note: A brake is not available for the 1326AS-B2 motor.

Option Designator	Holding torque N-m (lb-in.)	Current draw when energized (24V DC input)	Brake response time (ms) Pickup/Dropout	Weight added to motor weight kg (lb)	Inertia added to motor inertia kg-m ² (lb-in.-s ²)	Cold Resistance (Ohms)		Mechanical Backlash Degrees, minutes
						@ 25° C (77° F)	@ 40° C (104° F)	
-K3	2.26 (20)	0.50A DC	38/10	0.8 (1.8)	0.000008 (0.00007)	48	63	1,30
-K4	10.2 (90)	0.69A DC	44/13	2.1 (4.6)	0.00008 (0.0007)	35	45	0,44
-K6	36.7 (325)	1.22A DC	114/11	6.3 (14)	0.00035 (0.0031)	19	25	0,18
-K8	50.8 (450)	2.0A DC	200/12	15 (33)	0.0020 (0.018)	12	15	1,18

Shaft Oil Seal

Allen-Bradley offers a Nitrile shaft oil seal kit that you can install on the motor shaft in the field. Use the seal in applications where the motor shaft may be subjected to occasional oil splashes or low pressure water jetting (For example: If the motor is exposed to splashing from coolant nozzles).

Important: The kit is not intended to be used in applications where the motor shaft is partially or fully submerged in oil.

Motor Junction Box Kit

The Motor Junction Box Kit allows the existing motor connectors to be mounted axially (rather than radially) without further wiring. Motors with IP65 protection maintain their rating when using this option.

Note: The connector may be mounted to the face or rear of the motor.

Figure 15
Motor Junction Box Dimensions

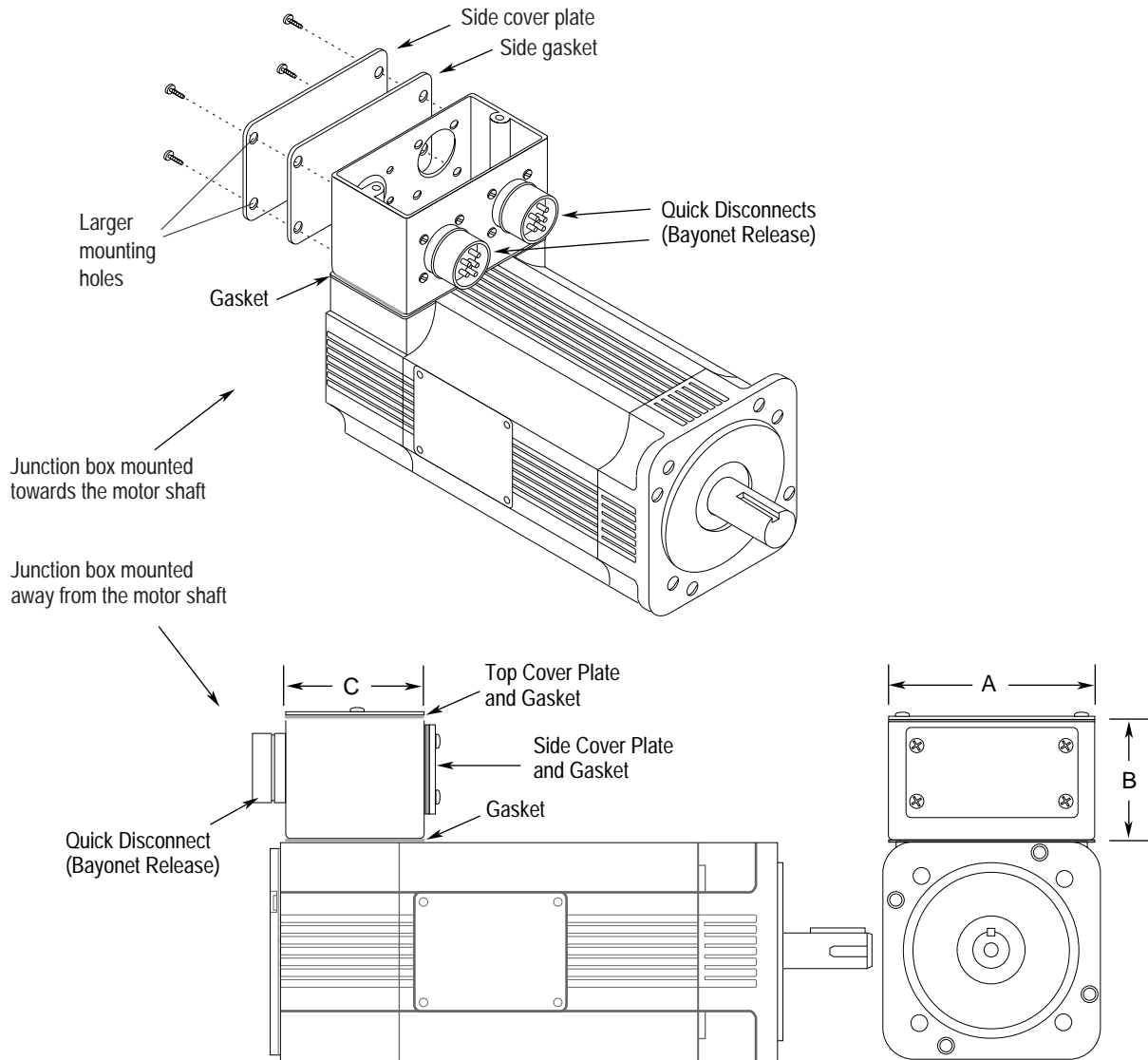

The dimensions of the motor junction box are given in the table below.

Dimension:	Is:
A	92.07 mm (3.62 in.)
B	69.85 mm (2.75 in.)
C	63.50 mm (2.50 in.)

1326-CCU-xxx Standard Commutation Cable for Motor Resolver

Wire Color	Gauge mm ² (AWG)	Connector Pin	System Module Terminal #
Black (Axis_0_R1)	0.519 (20)	A	1
White (Axis_0_R2)	0.519 (20)	B	6
Shield - Drain	0.519 (20)	no connection	2
Black (Axis_0_S1)	0.519 (20)	D	3
Red (Axis_0_S3)	0.519 (20)	E	8
Shield - Drain	0.519 (20)	no connection	7
Black (Axis_0_S4)	0.519 (20)	H	9
Green (Axis_0_S2)	0.519 (20)	G	4
Shield - Drain	0.519 (20)	no connection	5
Overall Shield	N/A	no connection	10

1326-CCUT-xxx Flex Rated Commutation Feedback Cable for Motor Resolver

Wire Color	Gauge mm ² (AWG)	Connector Pin	System Module Terminal #
White/Black (Axis_0_R1)	0.519 (20)	A	1
White (Axis_0_R2)	0.519 (20)	B	6
Shield	0.519 (20)	no connection	2
White/Black (Axis_0_S1)	0.519 (20)	D	3
White/Red (Axis_0_S3)	0.519 (20)	E	8
Shield	0.519 (20)	no connection	7
White/Black (Axis_0_S4)	0.519 (20)	H	9
White/Green (Axis_0_S2)	0.519 (20)	G	4
Shield	0.519 (20)	no connection	5
Green/Yellow	N/A	no connection	10

1326-CPB1-xxx Standard Motor Power Cable for 1326AS-B3xxx and 1326AS-B4xxx Servo Motors

Wire Number	Wire Color	Gauge mm ² (AWG)	Connector Pin	1394 Terminal
1 (Power)	Black	1.30 (16)	1	U1
2 (Power)	Black	1.30 (16)	2	V1
3 (Power)	Black	1.30 (16)	3	W1
4 (Brake)	Black	1.30 (16)	4	TB1-3
5 (Thermostat)	Black	1.30 (16)	5	TB1-2
6 (Brake)	Black	1.30 (16)	6	TB1-4
Braided shield	Braided shield	N/A	7	PE3
(GND)	Green/Yellow	1.30 (16)	8	PE2
9 (Thermostat)	Black	1.30 (16)	9	TB1-1

1326-CPC1-xxx Standard Power Cable for the 1326AS-B6xxx and 1326AS-B8xxx Servo Motors

Wire Number	Wire Color	Gauge mm ² (AWG)	Connector Pin	1394 Terminal
1 (Power)	Black	5.3 (10)	1	U1
2 (Power)	Black	5.3 (10)	2	V1
3 (Power)	Black	5.3 (10)	3	W1
4 (Brake)	Black	1.3 (16)	4	TB1-3
5 (Thermostat)	Black	1.3 (16)	5	TB1-2
6 (Brake)	Black	1.3 (16)	6	TB1-4
Braided shield	Braided shield	N/A	7	PE3
(GND)	Green/Yellow	3.3 (12)	8	PE2
9 (Thermostat)	Black	1.3 (16)	9	TB1-1

1326-CPB1T-xxx Flex Rated Power Cable for 1326AS-B3xxx and 1326AS-B4xxx Servo Motors

Wire Number	Wire Color	Gauge mm ² (AWG)	Connector Pin	1394 Terminal
1 (Power)	White	1.3 (16)	1	U1
2 (Power)	White	1.3 (16)	2	V1
3 (Power)	White	1.3 (16)	3	W1
4 (Brake)	White	1.3 (16)	4	TB1-3
5 (Thermostat)	White	1.3 (16)	5	TB1-2
6 (Brake)	White	1.3 (16)	6	TB1-4
Braided Shield	Braided Shield	N/A	7	PE3
(GND)	Green/Yellow	1.3 (16)	8	PE2
9 (Thermostat)	White	1.3 (16)	9	TB1-1

1326-CPC1T-xxx Flex Rated Power Cable for the 1326AS-B6xxx 1326AS-B8xxx Servo Motors

Wire Number	Wire Color	Gauge mm ² (AWG)	Connector Pin	1394 Terminal
1 (Power)	White	5.3 (10)	1	U1
2 (Power)	White	5.3 (10)	2	V1
3 (Power)	White	5.3 (10)	3	W1
4 (Brake)	White	1.3 (16)	4	TB1-3
5 (Thermostat)	White	1.3 (16)	5	TB1-2
6 (Brake)	White	1.3 (16)	6	TB1-4
Braided Shield	Braided Shield	N/A	7	PE3
(GND)	Green/Yellow	3.3 (12)	8	PE2
9 (Thermostat)	White	1.3 (16)	9	TB1-1

For more information refer to our web site: www.ab.com/motion

Reach us now at www.rockwellautomation.com

Wherever you need us, Rockwell Automation brings together leading brands in industrial automation including Allen-Bradley controls, Reliance Electric power transmission products, Dodge mechanical power transmission components, and Rockwell Software. Rockwell Automation's unique, flexible approach to helping customers achieve a competitive advantage is supported by thousands of authorized partners, distributors and system integrators around the world.

Americas Headquarters, 1201 South Second Street, Milwaukee, WI 53204, USA, Tel: (1) 414 382-2000, Fax: (1) 414 382-4444
European Headquarters SA/NV, avenue Hermann Debroux, 46, 1160 Brussels, Belgium, Tel: (32) 2 663 06 00, Fax: (32) 2 663 06 40
Asia Pacific Headquarters, 27/F Citicorp Centre, 18 Whitfield Road, Causeway Bay, Hong Kong, Tel: (852) 2687 4788, Fax: (852) 2508 1846

