

ACCU ELECTRIC MOTORS INC

USA: (888) 932-9183

CANADA: (905) 829-2505

- ✓ Over 100 years cumulative experience
- ✓ 24 hour rush turnaround / technical support service
- ✓ Established in 1993



The leading independent repairer of servo motors and drives in North America.

Visit us on the web:

www.servo-repair.com

www.servorepair.ca

www.ferrocontrol.com

www.sandvikrepair.com

www.accuelectric.com

Scroll down to view your document!

For 24/7 repair services :

USA: 1 (888) 932 - 9183

Canada: 1 (905) 829 -2505

Emergency After hours: 1 (416) 624 0386

Servicing USA and Canada

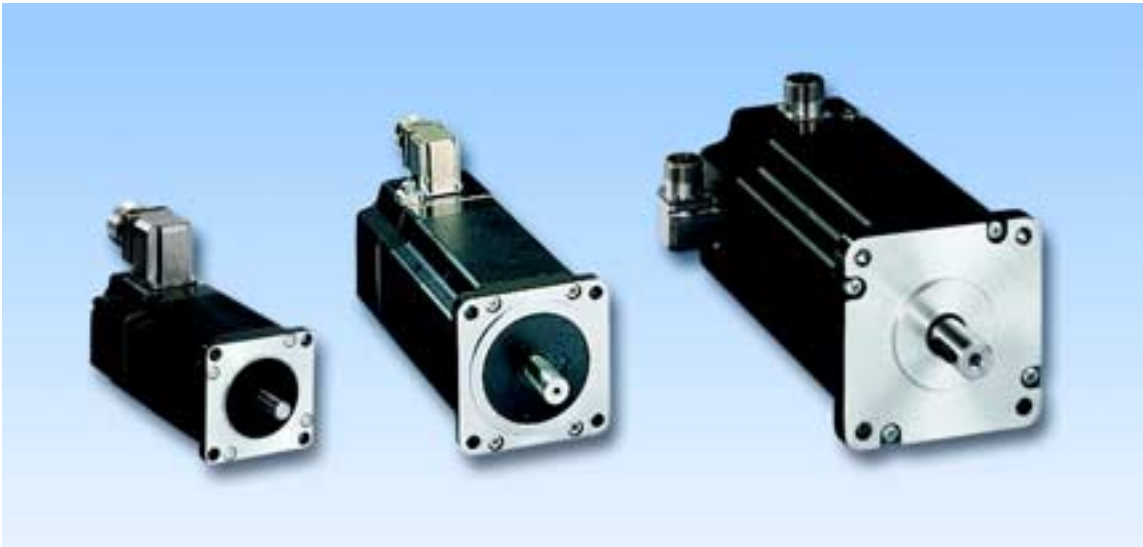

Series of 3-phase stepping motors

3-phase stepping motors

Features

3-phase stepping motors from Berger Lahr are:

- **Powerful** because the optimised internal geometry results in a high power intensity, meaning up to 50 % more torque than standard stepping motors of comparable size.
- **Quiet** due to the sinusoidal commutation of the Twin Line power electronics and the special mechanical construction - the stepping motor runs quietly and virtually resonance-free.
- **Economical** because of the high power intensity, simple wiring and compact Twin Line power electronics.

Characteristic curves

The measurements were performed at a step count of 1000 steps per revolution.

The following characteristic curves are depicted:

- Operating-limit torque curve
- Start-stop curve (start frequency depends on load torque)
- Load inertia curve for start-stop operation

The characteristic curves were generated at the following operating currents:

- VRDM 368 with TLD 011: 0.9 A
- VRDM 397 with TLD 011: 1.75 A
- VRDM 3910 with TLD 011: 2.0 A
- VRDM 3913 with TLD 011: 2.25 A
- VRDM 31117 with TLD 012: 4.0 A
- VRDM 31122 with TLD 012: 4.75 A

Technical specifications

- Testing voltage according to DIN VDE 0530
- Protection type:
 - Motor housing: IP 56
 - Shaft end, front: IP 41
- Insulation class F
- Motor with 90° mounting socket
- Size (flange)
 - VRDM 368 (57.2 x 57.2 mm²)
 - VRDM 39x (85 x 85 mm²)
 - VRDM 311x (110 x 110 mm²)

Optional accessories

- Encoder (1000) for rotation monitoring, including integrated temperature sensor for monitoring the motor temperature
- Integrated holding brake
- Gearbox

Environmental influences

Ambient conditions (based on DIN 50019-R14):

- Temperature: -25 °C to +40 °C
- Humidity: ≤ 75 % R.H. yearly average, 95 % R.H. on 30 days, non-condensing

Storage and transport temperature:

- Temperature: -25 °C to +70 °C

Technical data

		VRDM 368	VRDM 397	VRDM 3910	VRDM 3913	VRDM 31117	VRDM 31122
Max. torque	M_{max}	150 Ncm	200 Ncm	400 Ncm	600 Ncm	1200 Ncm	1650 Ncm
Holding torque	M_H	174 Ncm	226 Ncm	452 Ncm	678 Ncm	1392 Ncm	1914 Ncm
Rotor inertia	J_R	0.38 kgcm ²	1.1 kgcm ²	2.2 kgcm ²	3.3 kgcm ²	10.5 kgcm ²	16 kgcm ²
Max. start frequency	F_{Aom}	6 kHz	5.3 kHz	5.3 kHz	5.3 kHz	4.7 kHz	4.7 kHz
Rated current/ supply	I_ω	0.9 A	1.8 A	2.0 A	2.3 A	4.1 A	4.8 A
Resistor/winding	R_ω	25 Ω	6.5 Ω	5.8 Ω	6.5 Ω	1.8 Ω	1.9 Ω
Current rise-time constant	τ	4.6 ms	7 ms	9 ms	10 ms	22 ms	22 ms
Permissible dynamic shaft load, axial		8.4 N	60 N	60 N	60 N	60 N	60 N
Permissible dynamic shaft load, radial		50 N	100 N	100 N	110 N	300 N	300 N
Mass	G	1.1 kg	2.5 kg	3.1 kg	4.2 kg	8.0 kg	11 kg

VRDM 3x

Motor voltage	U	325 V
Step count	z	200/400/500/1000/2000/4000/5000/10000
Stepping angle per step	a	1.8/0.9/0.72/0.36/0.18/0.09/0.072/0.036 °
Encoder line count (optional)		1000

Characteristic curves

3-phase stepping motors

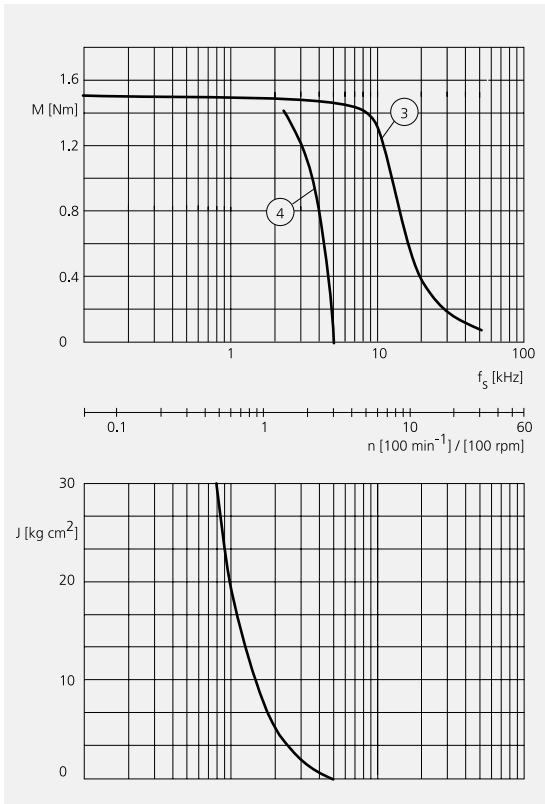

VRDM 368 with TLD 011

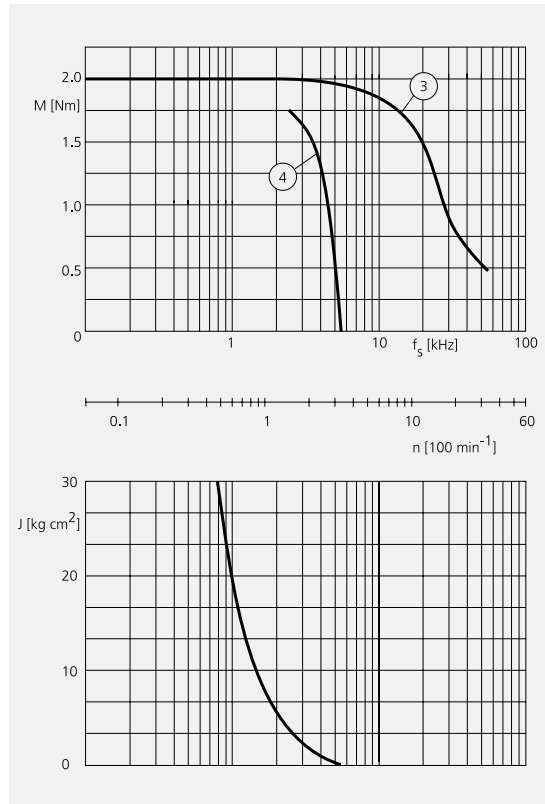

VRDM 397 with TLD 011

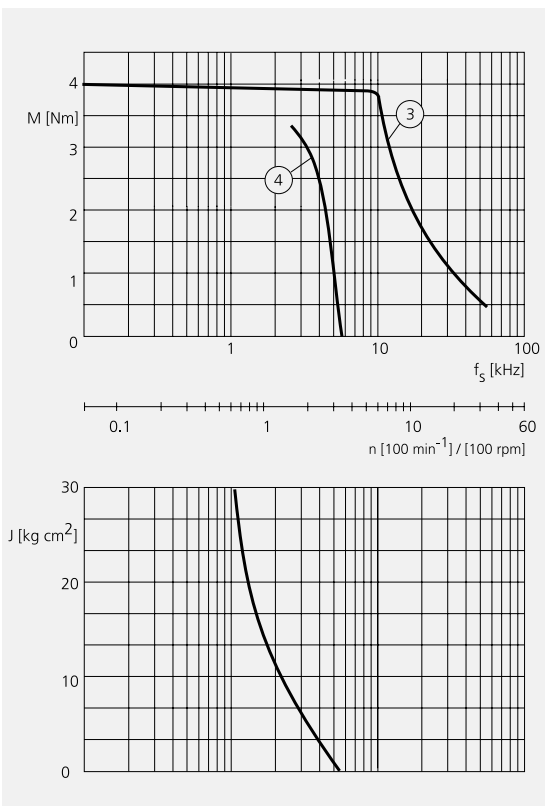

VRDM 3910 with TLD 011

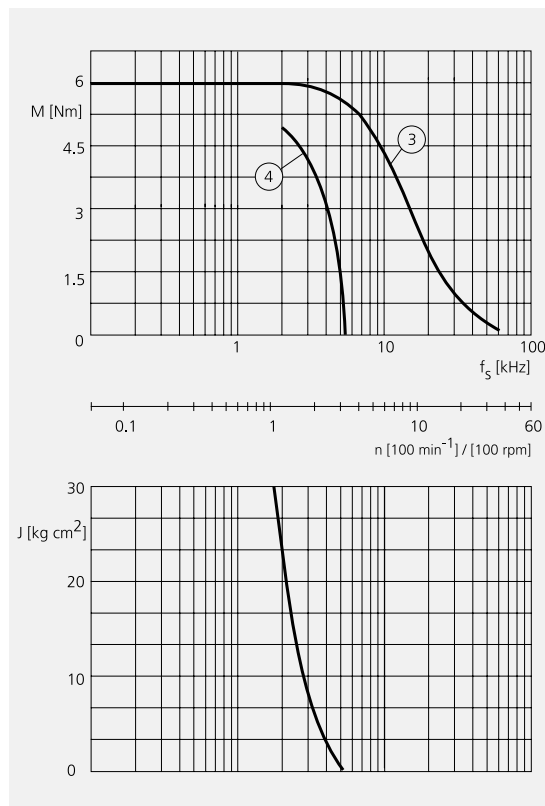

VRDM 3913 with TLD 011

- 3 Operating-limit torque
- 4 Start-stop curve

3-phase stepping motors

Characteristic curves

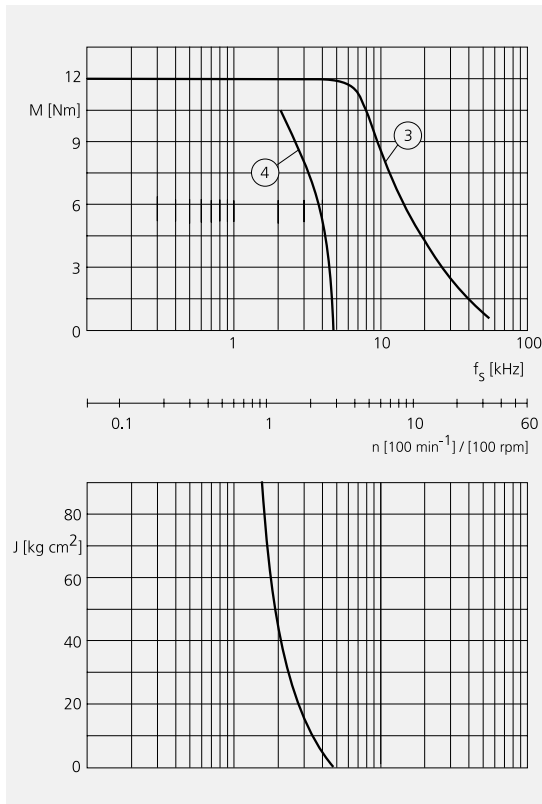

VRDM 31117 with TLD 012

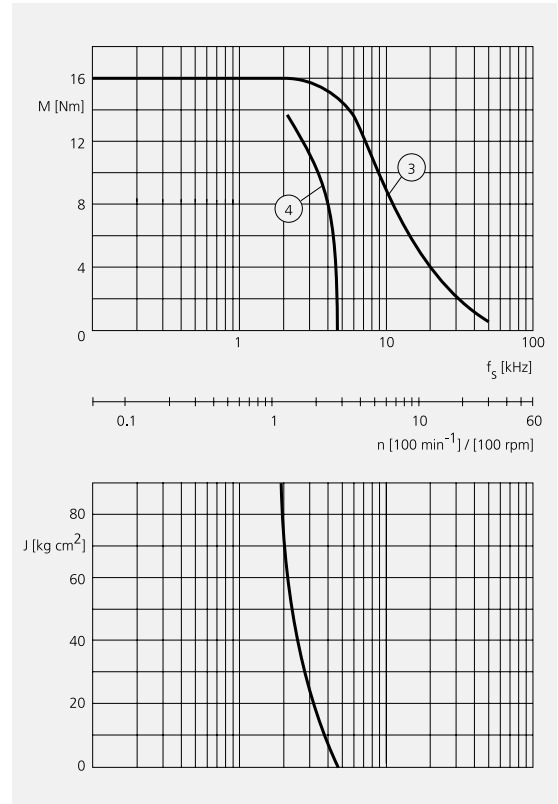

VRDM 31122 with TLD 012

- 3 Operating-limit torque
- 4 Start-stop curve

Dimensional drawings

3-phase stepping motors

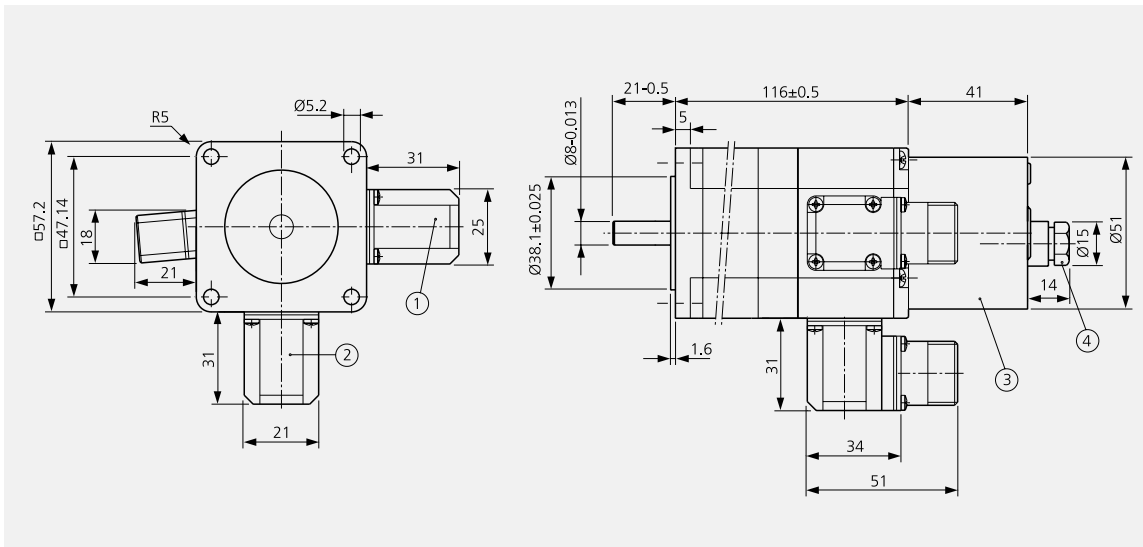

VRDM 368

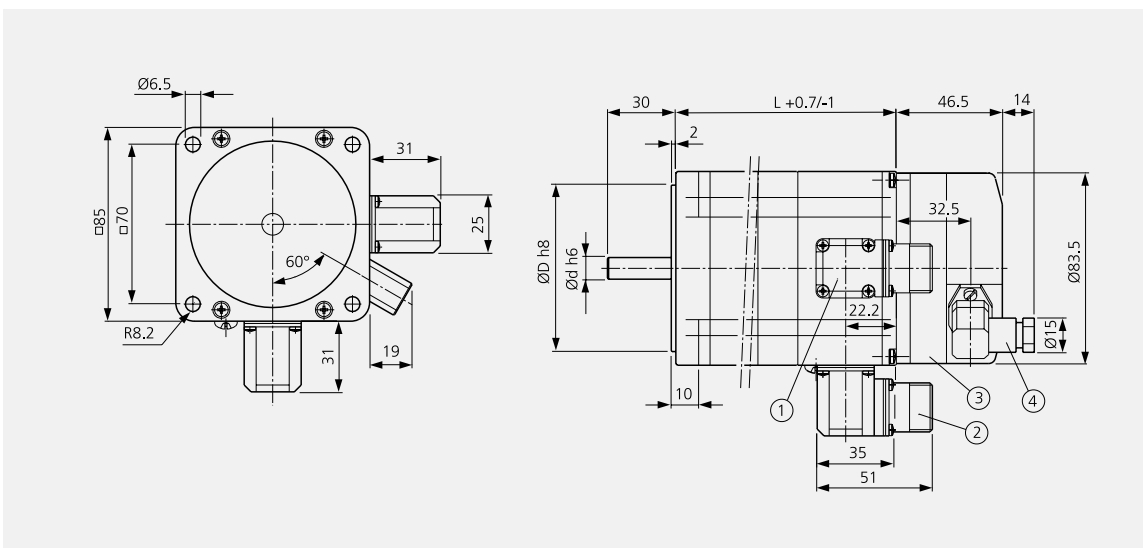

VRDM 397, 3910, 3913

- 1 Encoder connector
- 2 Motor connector
- 3 Brake
- 4 Brake connector

3-phase stepping motors

Dimensional drawings

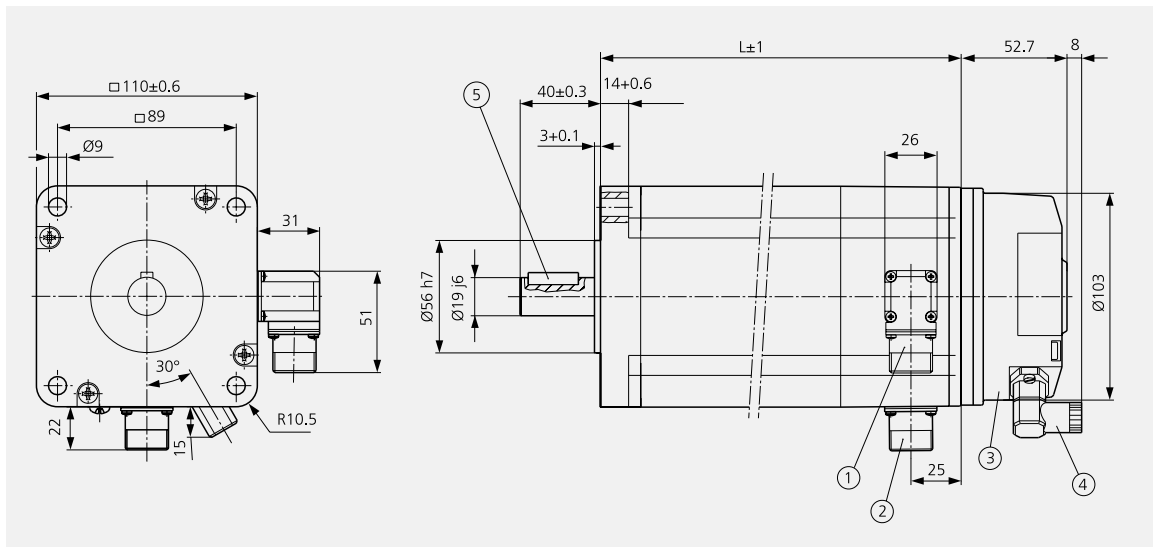

VRDM 31117, 31122

- 1 Encoder connector
- 2 Motor connector
- 3 Brake
- 4 Brake connector
- 5 Feather key

Dimensions

		VRDM 368	VRDM 397	VRDM 3910	VRDM 3913	VRDM 31117	VRDM 31122
Shaft diameter	d	8 mm	12 mm	12 mm	14 mm	19 mm	19 mm
Shaft construction		Smooth shaft	Smooth shaft	Smooth shaft	Smooth shaft	Washer/ featherkey A6 x 6 x 25 DIN 6885	Washer/ featherkey A6 x 6 x 25 DIN 6885
Length	L	116 mm	110 mm	140 mm	170 mm	180 mm	228 mm
Centering collar	D	38.1 mm	60 mm	60 mm	60 mm	56 mm	56 mm



3-phase stepping motor with holding brake

Holding brake

The holding brake is an electromagnetic spring-pressure brake for locking the motor axle after the motor current is shut off. In emergency situations, such as in a power failure or during an EMERGENCY STOP, it shuts down the drive, significantly contributing to overall safety. The motor axle must also be locked for weight-induced torque loads, e.g. in cases of vertical axes in manual mode.

Holding brake controller

The holding brake can be controlled either directly or via the **Twin Line Holding Brake Controller**, which is available as an accessory.

The TL HBC reduces heating of the brake by lowering the pickup voltage.

Caution! Overloading may damage the holding brake! Avoid stationary load torques greater than 25 % of the motor holding torque when using vertical axes with the holding brake.

Technical data of the holding brake

	VRDM 36x	VRDM 39x	VRDM 311x
Holding torque	1 Nm	6 Nm	16 Nm
Armature inertia	0.016 kgcm ²	0.2 kgcm ²	0.35 kgcm ²
Electrical pickup power	8 W	24 W	32 W
Energise time	58 ms	35 ms	65 ms
De-energise time	14 ms	15 ms	15 ms
Weight	0.5 kg	1.5 kg	2.0 kg



3-phase stepping motor with encoder (cover removed)

Encoder

The encoder reports the actual motor position, provided the power controller is equipped with rotation monitoring electronics. The rotation monitoring system compares the set and actual positions of the motor and reports an error if the difference exceeds a limit (drag-error limit). One advantage of this system is that it can detect and prevent the motor from overloading.

The encoder is fitted in the connector housing – the motor length is unaffected.

The encoder option also includes integrated motor-temperature monitoring. The temperature is evaluated via the data-monitoring option of the Twin Line device.

	VRDM
Resolution	1000 incr./revolutions
Index pulse	1 pulse/revolution
Output	RS 422
Signals	A, B, \bar{A} , \bar{B} , 0, $\bar{0}$
Impulse form	Rectangular
Supply voltage	5 V \pm 5 %
Supply current	0.15 A
Working temperature range	0 to 100 °C



PL 10 and PL 50 planetary gears

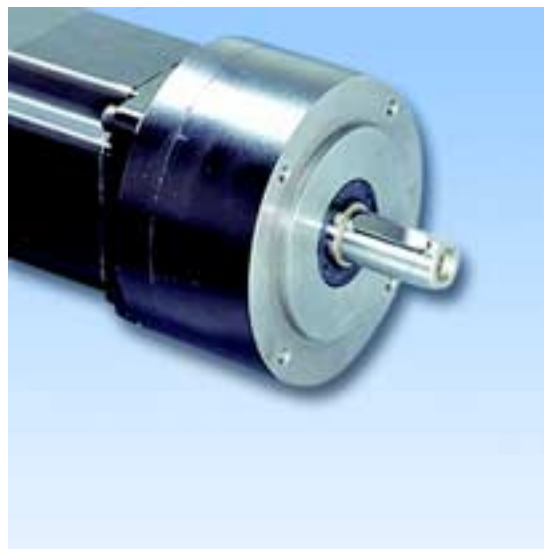

PL 100 planetary gear

Gearbox PL 10 ... PL 115

Gearbox data for all types

Gearbox type	Single-stage straight-toothed planetary gear
Nominal storage life*	$L_{10h} = 20000$ h
Torsional flank clearance	$< 12'$, PL 115 $< 3'$
Housing material	Aluminium
Surface	Anodised black
Shaft material	C 45
Bearing	Roller bearing
Sealing at shaft end	IP 54
Lubrication	Grease-lubricated for entire service life
Temperature range	-20 °C to $+80$ °C

* Value in operating hours with a 10 % likelihood of failure; 100 % duty cycle at continuous output torque; operating mode S1 (continuous operation); storage temperature = 30 °C

The PL 10 / 50 / 100 / 115 gearboxes are delivered already mounted to the motor. They can be ordered using the type key for the motor.

	1	2	3	4	5	J	M_{DG}	M_{max}
		kg	N	N		kgcm²	Nm	Nm
VRDM 368 with PL 10	3:1	0.73	225	290	0.9	0.61	10	4.05
	5:1					0.21	14	6.75
	10:1					0.07	7.5	13.5
VRDM 397 with PL 50	3:1	2.3	550	580	0.9	0.63	38	5.4
	5:1					0.14	50	9
	10:1					0.07	41	18
VRDM 3910 with PL 50	3:1	2.3	550	580	0.9	0.63	38	10.8
	5:1					0.14	50	18
	10:1					0.07	41	36
VRDM 3913 with PL 50	3:1	2.3	550	580	0.9	0.63	38	16.2
	5:1					0.14	50	27
	10:1					0.07	41	54
VRDM 31117 with PL 100	3:1	8.75	760	760	0.9	1.5	100	32.4
	5:1					0.7	100	54
	10:1					0.5	80	108
VRDM 31122 with PL 100	3:1	8.75	760	760	0.9	1.5	100	44.55
	5:1					0.7	100	74.25
	10:1					0.5	80	148.5
VRDM 31122 with PL 115	10:1	9	3200	6500	0.98	1.0	125	148.5

- | | | | |
|---|---|------------------|--|
| 1 | Reduction ratio | 5 | Efficiency |
| 2 | Gearbox mass | J | Gearing inertia |
| 3 | Max. permissible radial force at $n_{2^*} = 400 \text{ min}^{-1}$ | M _{DG} | Continuous output torque of the gearbox in the continuous endurance range of the toothed parts (motor not taken into account). |
| 4 | Max. permissible axial force at $n_{2^*} = 400 \text{ min}^{-1}$ | M _{max} | Max. torque at output (gearbox with motor, efficiency taken into account) |
- *Gear output speed

Note: M_{DG} may not be exceeded for a long period of time. Dual torque is possible for short periods, e. g. for EMERGENCY STOP situations.

Additional gearboxes are available upon request.

3-phase stepping motors

Gearbox options

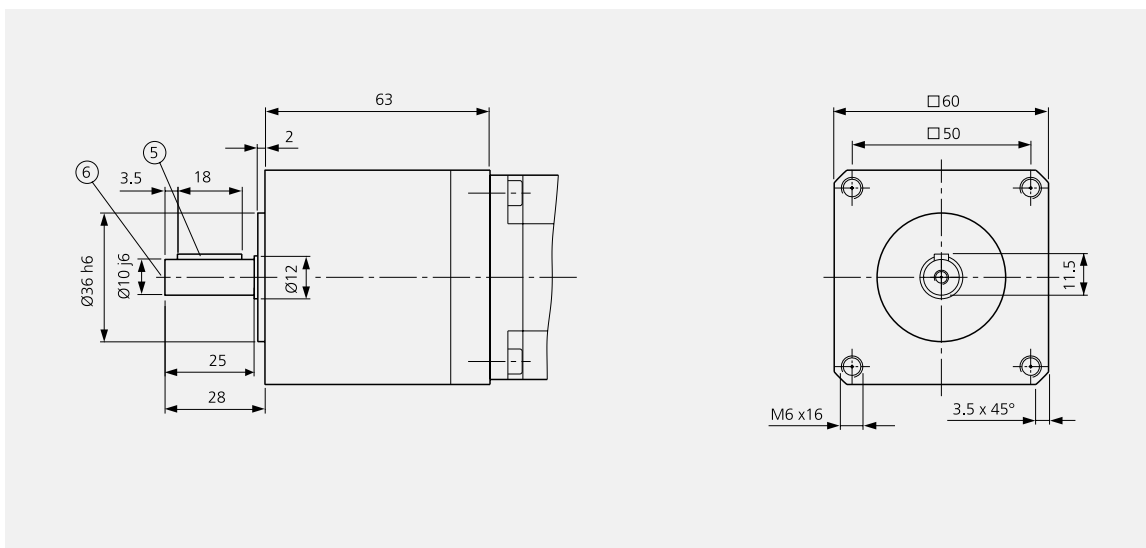

Dimensional drawing of 3-phase stepping motor, size 60, with PL 10 planetary gear

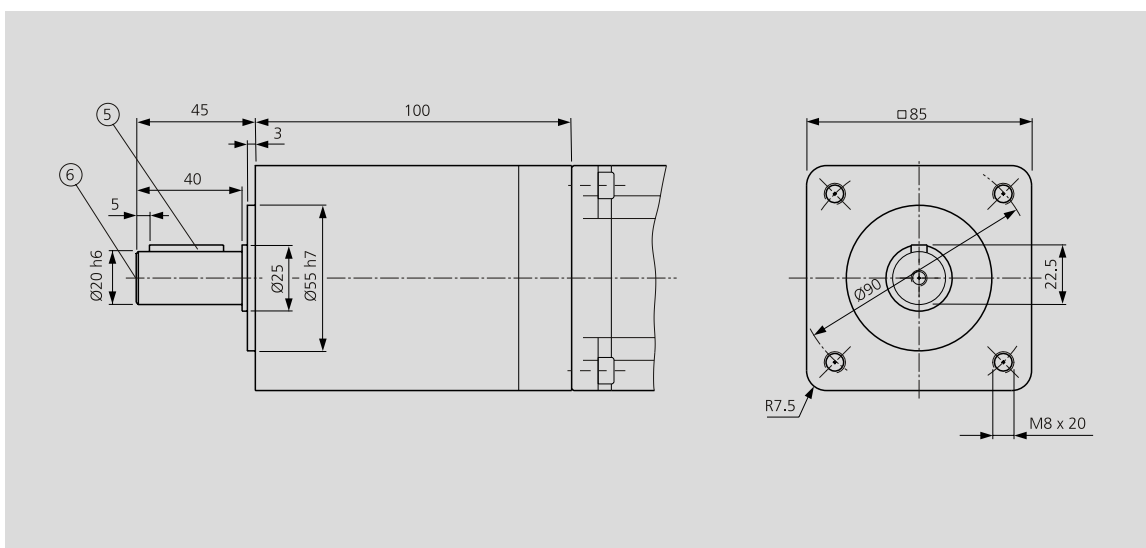

Dimensional drawing of 3-phase stepping motor, size 90, with PL 50 planetary gear

- 5 Featherkey
- 6 Centre hole

	Gearbox	Featherkey	Centre hole
PL 10	DIN 6885 A4 x 4 x 18	DIN 332 DS M4	
PL 50	DIN 6885 A6 x 6 x 28	DIN 332 DS M6	

Gearbox options

3-phase stepping motors

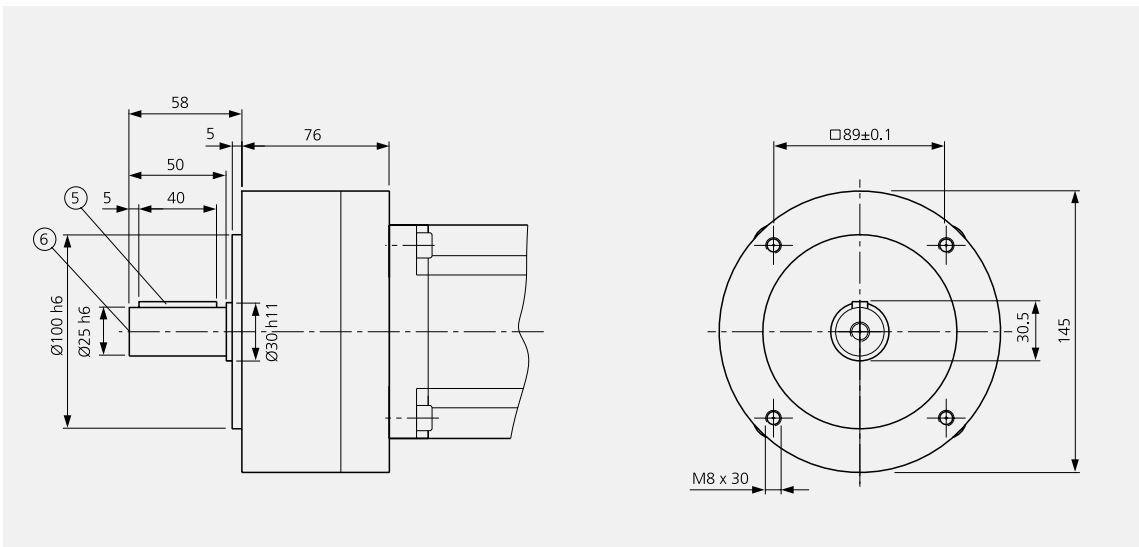

Dimensional drawing of 3-phase stepping motor, size 110, with PL 100 planetary gear

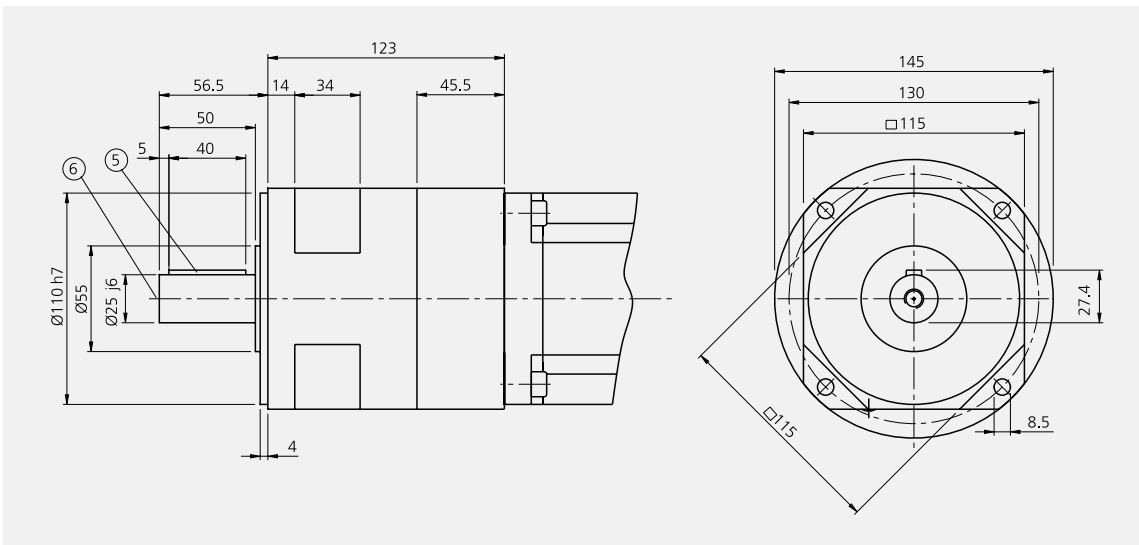

3-phase stepping motor, size 110, with PL 115 planetary gear

- 5 Featherkey
- 6 Centre hole

Gearbox	Featherkey	Centre hole
PL 100	DIN 6885 A8 x 7 x 40	DIN 332 DS M10
PL 115	DIN 6885 A8 x 7 x 40	DIN 332 DS M15

3-phase stepping motors

Type key

Example	VRDM	3	X	X	L	W	C	X	X	X	X
Number of phases 3	VRDM	3	X	X	L	W	C	X	X	X	X
Size (flange) 6 (57,2 mm) 9 (85 mm) 11 (110 mm)	VRDM	3	X	X	L	W	C	X	X	X	X
Length 7 8 10 13 17 22	VRDM	3	X	X	L	W	C	X	X	X	X
Rotor L = laminated rotor	VRDM	3	X	X	L	W	C	X	X	X	X
Motor voltage W = 325 V	VRDM	3	X	X	L	W	C	X	X	X	X
Motor connection C = with connector 90°	VRDM	3	X	X	L	W	C	X	X	X	X
Holding brake B = with brake O = without brake	VRDM	3	X	X	L	W	C	X	X	X	X
Encoder E = with encoder O = without encoder	VRDM	3	X	X	L	W	C	X	X	X	X
Gearbox type PL 10 PL 50 PL 100 PL 115	VRDM	3	X	X	L	W	C	X	X	X	X
Gearbox ratios I3 = 3:1 I5 = 5:1 I10 = 10:1	VRDM	3	X	X	L	W	C	X	X	X	X