

ACCU ELECTRIC MOTORS INC

USA: (888) 932-9183

CANADA: (905) 829-2505

- ✓ Over 100 years cumulative experience
- ✓ 24 hour rush turnaround / technical support service
- ✓ Established in 1993



The leading independent repairer of servo motors and drives in North America.

Visit us on the web:

www.servo-repair.com

www.servorepair.ca

www.ferrocontrol.com

www.sandvikrepair.com

www.accuelectric.com

Scroll down to view your document!

For 24/7 repair services :

USA: 1 (888) 932 - 9183

Canada: 1 (905) 829 -2505

Emergency After hours: 1 (416) 624 0386

Servicing USA and Canada

Servodyn-D

Diagnosics, maintenance

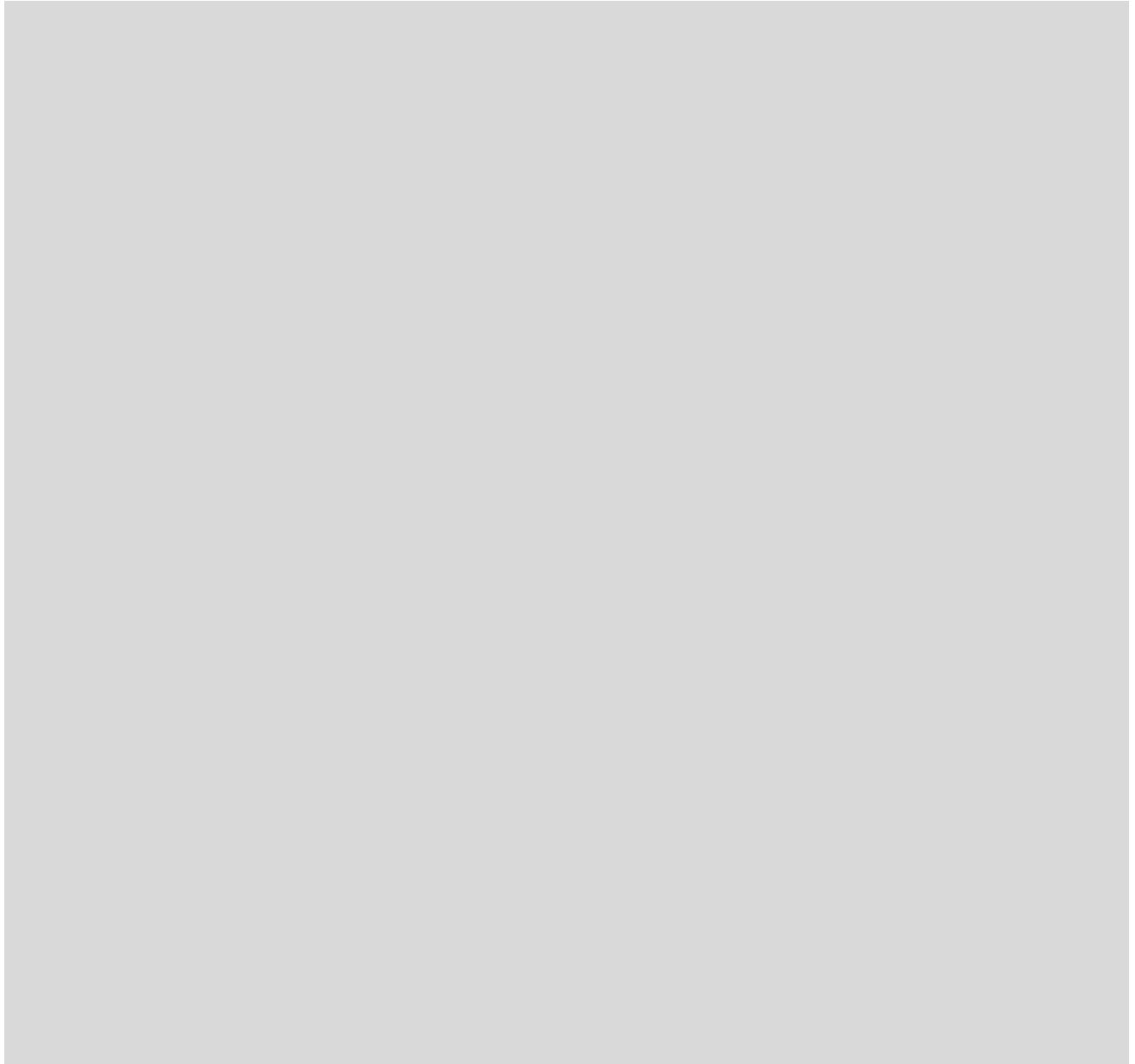

Edition

102

Servodyn-D

Diagnostics, maintenance

1070 066 032-102 (98.07) GB



Reg. no. 16149-03

© 1998

by Robert Bosch GmbH, Erbach / Germany
All rights reserved, including applications for protective rights.
Reproduction or handing over to third parties are subject to our written permission.

Discretionary charge 10.00 DM

Table of contents

	Page
Safety instructions	VII
1 Mains connection at the place of installation	1–1
2 Diagnostics displays at the drive	2–1
2.1 VM..K Status displays	2–1
2.2 Status displays VM..B,C,D	2–2
2.3 Warning displays VM..B,C,D	2–3
2.4 Status displays DM and DS (without frequency inverter)	2–4
2.5 Error displays (without frequency inverter)	2–5
2.6 DM computer errors (without SERCOS interface)	2–11
2.7 Servodyn–D frequency inverter displays	2–12
2.7.1 Status/warning displays	2–12
2.7.2 Error displays	2–14
3 Connection overview	3–1
3.1 Supply module VM..K	3–1
3.2 Supply module VM..B,C,D	3–2
3.3 Three–phase current module DM with analog interface or positioning function	3–3
3.4 Frequency inverter DM...8001–D with analog interface .	3–4
3.5 Three–phase current module DM with CAN bus	3–5
3.6 Three–phase current module DM with SERCOS interface	3–6
3.7 Stand–alone module DS, supply unit	3–7
4 Replacing components	4–1
4.1 Motors	4–1
4.2 Drive modules	4–3
4.2.1 DC link connection of VM..B,C,D and DM..A,B,D with backplane modules	4–3
4.2.2 VM...K and DM...K	4–4
A Appendix	A–1

Safety instructions

Store this manual in a place to which all users have access at any time.

Proper use

These products normally pose no danger to persons or property if they are used in accordance with the handling stipulations and safety notes prescribed for their configuration, mounting, and proper operation.

The present manual contains all instructions required for their proper use. The drive inverters described are components to be installed in metallic switch cabinets of machines and systems for industrial use.

The low-voltage motors described are designed for **commercial or industrial** applications. They comply with the harmonized standards of the VDE 0530 / EN60034 series. Their use in potentially explosive atmospheres is not admissible unless expressly permitted by additional notes.

Air-cooled designs are rated for ambient conditions between -20 °C up to $+40\text{ °C}$ and an erection height of ≤ 1000 above mean sea level. Different data on the nameplate must be observed under all circumstances. The conditions at the place of erection must match all data stated on the nameplate.

- Before putting the drive inverters into operation, ensure that the machine which the inverters are to be installed in meets the stipulations of the machine directive (89/392/EEC) and the EMC directive (89/336/EEC).
- The inverters themselves meet the safety objectives of the low-voltage directive (73/23/EEC) and the harmonized standards EN 50178 (VDE 0160) and EN 60146-1-1 (VDE 0558-11).
- Low-voltage motors are **components** to be installed in machines as defined by the machine directive 89/392/EEC.
Before putting them into operation, ensure that the machine which the motors are to be installed in meets the stipulations of the machine directive (note also EN 60204-Part 1).

The products described

- have been developed, manufactured, tested, and documented in compliance with the safety standards. These products normally pose no danger to persons or property if they are used in accordance with the handling stipulations and safety notes prescribed for their configuration, mounting, and proper operation.
- meet the requirements of the EMC directive (89/336/EEC, 93/68/EEC, and 93/44/EEC) and the low-voltage directive (73/23/EEC). In particular, the EMC product standard EN 61800-3 is complied with.
- are designed for operation in industrial environments. For operation in residential environments, in trade and commercial applications and small enterprises, an individual permit of the national authority or test institution is required; in Germany, please contact the Bundesanstalt für Post und Telekommunikation or its local branch offices.

The faultless, safe functioning of the product requires proper transport, storage, erection and installation as well as careful operation.

Qualified personnel

The requirements as to qualified personnel depend on the qualification profiles described by ZVEI (central association of the electrical industry) and VDMA (association of German machine and plant builders) in:

Weiterbildung in der Automatisierungstechnik

edited by: ZVEI and VDMA

MaschinenbauVerlag

Postfach 71 08 64

D-60498 Frankfurt

The present manual is designed for drive technicians.

Interventions in the hardware and software of our products, unless described otherwise in this manual, are reserved to our specialized personnel.

Tampering with the hardware or software, ignoring warning signs attached to the components, or non-compliance with the warning notes given in this manual can result in serious bodily injury or property damage.

For this reason, only **electrotechnicians** as recognized under VDE 1000-10 who are familiar with the contents of this manual may install and service the products described. Furthermore, all existing accident prevention regulations (in Germany: UVV VBG4, VDE 100, VDE 105) and installation instructions (EN 60204-Part 1, EN 50178) must be observed.

Such personnel are

- those who, being well trained and experienced in their field and familiar with the relevant norms, are able to analyze the jobs being carried out and recognize any hazards which may have arisen.
- those who have acquired the same amount of expert knowledge through years of experience that would normally be acquired through formal technical training.

Insufficiently trained or untrained personnel may produce severe damages to the machine and drives, loss of software or even personal injury!

Programming, start and operation as well as the modification of program parameters is therefore reserved to properly trained personnel! This personnel must be able to judge potential hazards arising from programming, program changes and in general from the mechanical, electrical, or electronic equipment.

Please note our comprehensive range of training courses.

Our training center will be pleased to provide you with further information, telephone: +49 (0)6062 78-258.

Safety markings on components

Warning of dangerous electrical voltage!



Warning of hot surface > 60°C!



Protect against impact and shock!



Electrostatically sensitive components!



Pin for connecting PE conductor only!



Conductor shield

**The warning signs attached to the motors**

- dangerous electrical voltage, and
- hot surface

must be attached to the motors after installation in a visible location in accordance with the machine directive 89/392/EEC if motor surfaces are exposed.

Safety instructions in this manual



DANGEROUS ELECTRICAL VOLTAGE

This symbol is used to warn of a **dangerous electrical voltage**. The failure to observe the instructions in this manual in whole or in part may result in **personal injuries**.



DANGER

This symbol will be used if the failure to observe the instructions in this manual in whole or in part may result in **personal injuries**.



CAUTION

This symbol will be used if the failure to observe the instructions in this manual in whole or in part may result in **damages to equipment or files**.



This symbol will be used to draw the user's attention to special circumstances.

- ★ This symbol refers to an activity to be performed by the user.

Key operation

Special keys or combinations of keys are represented by pointed brackets

- Special keys: e.g. <enter>, <pgup>,
- Key combinations (pressed simultaneously): e.g. <ctrl>+<pgup>

Modifications

Those paragraphs in this edition which are modified versions of Edition 101 are marked by black vertical bars on the margin.

Safety instructions

**DANGER**

Danger for persons and equipment!

Test every new program before starting up a system!

**DANGEROUS ELECTRICAL VOLTAGE**

Lethal voltages of up to 375 V DC against ground on all power connections and DC link connections!

The drives must not be switched on unless all covers have been fitted!

When the drive has been disconnected from mains, wait for up to 5 minutes until the system is de-energized before removing any covers.

The drive must always be examined for safe isolation from supply!

**DANGEROUS ELECTRICAL VOLTAGE**

Danger of life through electrical voltage!

Unless described otherwise, maintenance works must be performed on inactive systems! The system must be protected against unauthorized or accidental reclosing.

For measuring or test activities on the live system, the existing safety and accident prevention regulations must be observed in any case. Use suitable insulated tools for all types of work!

**DANGER**

Health hazards through destroyed electrical components!

Do not destroy any built-in components. Dispose of destroyed components in a proper manner.

Please note your local, system-specific regulations and requirements as well as the proper use of tools, hoisting and transport equipment as well as the applicable standards, regulations, and accident prevention regulations.

**CAUTION**

Danger to the module!

Observe all precautions for ESD protection when handling modules and components! Avoid electrostatic discharge!

The following protective measures must be observed for modules and components sensitive to electrostatic discharge (ESD)!

- The personnel responsible for storage, transport, and handling must have been trained for ESD protection.
- ESD-sensitive components must be stored and transported in their prescribed protective packaging.

- ESD-sensitive components may only be handled at special ESD-workplaces.
- Personnel, working surfaces, as well as all equipment and tools which get in contact with ESD-sensitive components must have the same potential (e.g., by grounding).
- Wear an approved grounding bracelet. The grounding bracelet must be connected with the working surface through a cable with an integrated resistor of 1 M Ω .
- ESD-sensitive components must by no means get in contact with chargeable objects, including most plastic materials.
- When ESD-sensitive components are installed in or removed from equipment, the equipment must be de-energized.

**DANGER**

Danger of life through inadequate EMERGENCY-STOP devices! EMERGENCY-STOP devices must be active and within reach in all system modes. Releasing an EMERGENCY-STOP device must not result in an uncontrolled restart of the system! First check the EMERGENCY-STOP circuit, then switch the system on.

**DANGER**

Retrofits or modifications may adversely affect the safety of the products described! The consequences may include severe injuries, damage to equipment, or environmental hazards. Possible retrofits or modifications to the system using third-party equipment therefore have to be approved by Bosch.

**CAUTION**

Repair/maintenance work is reserved to the Bosch service or repair/maintenance units authorized by Bosch! Only replacement/spare parts approved by Bosch may be used!

Documentation and Software

The present manual provides information on the Servodyn-D series of drives. The following documentation is additionally available:

Servodyn-D documentation	Part no.	
	German	English
Configuration manual for overview and rating	1070 066 009	1070 066 029
Servo motors SF, SR	1070 066 004	1070 066 024
Asynchronous motors DU	1070 066 007	1070 066 027
Interface conditions	1070 066 010	1070 066 030
Servodyn-D with SERCOS interface – Parameter and commissioning manual	1070 066 011	1070 066 031
Servodyn-D with analog interface – Parameter description	1070 066 013	–
Servodyn-D with analog interface – Commissioning manual	1070 066 014	1070 066 034
Diagnostics, maintenance	1070 066 012	1070 066 032
EMC manual	1070 066 072	1070 066 074
External load switching module	1070 066 077	1070 066 080

All trademarks for software installed on Bosch products upon delivery are the property of the respective manufacturers.

Upon delivery, all installed software is copyright-protected. The software may only be reproduced with the approval of Bosch or in accordance with the license agreement of the respective manufacturer.

1 Mains connection at the place of installation

**CAUTION**

Inverter modules may only be connected to earthed systems. Operation with indirectly earthed systems (IT systems) is not admissible because the clearances and creepage distances inside the module may be overloaded.

DIN VDE 0100–300 distinguishes between mains systems according to the type of earth connection.

Accordingly, in an IT system, all active parts are isolated from ground, or one point is connected to ground via an impedance.

The components of the electrical system are either

- grounded separately, or
 - grounded jointly, or
 - jointly connected to the system earth.
-

**CAUTION**

Operation at asymmetrical systems (one system phase grounded) is not admissible!

**DANGEROUS ELECTRICAL VOLTAGE**

Exclusively permissible protective measure to EN 50 178: TT protective system.

The protective conductor surface area must be at least 10 mm².

One-sided grounding of the DC link is not permissible if unit is operated via an isolating transformer!

**DANGEROUS ELECTRICAL VOLTAGE**

Leakage currents emerging from the DC link may disable e.l.c.b.'s type A.

Operation at a separate circuit protected by an e.l.c.b. type B is permissible. Please note the leakage currents of radio-interference suppression circuits.

**CAUTION**









An incorrect phase sequence or winding direction of a line reactor will destroy the power supply module.

Therefore, check wiring when a module has been replaced.





Your notes:

2 Diagnostics displays at the drive

2.1 VM..K Status displays

7-segment display	Status	Action
	Ready Standard ready display	–
	Warning: <ul style="list-style-type: none"> Excessive heat sink temperature Ballast switch may be overloaded VM power limit reached 	<ul style="list-style-type: none"> Increase air supply, reduce ambient temperature Reduce module load
	Undervoltage DC link voltage < 400 V	<ul style="list-style-type: none"> Switch module on Check system voltage
	Overvoltage DC link voltage > 750 V	<ul style="list-style-type: none"> Reduce braking current Check system voltage
	Ballast switch overload	<ul style="list-style-type: none"> Reduce braking current Set longer braking times
	Power supply fault Internal supply voltage outside permissible tolerance.	<ul style="list-style-type: none"> Check 24V voltage supply Replace module
	Module overtemperature Heat sink temperature > 75°C	<ul style="list-style-type: none"> Increase air supply Reduce ambient temperature
	Ambient overtemperature Ambient temperature > 55°C	<ul style="list-style-type: none"> Check operating conditions Observe derating

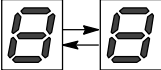
2.2 Status displays VM..B,C,D

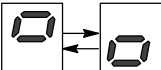
LED	Status	Action
 AE	Drive On LED lights up at 24 V at X06.7 (AE)	–
 FGI	Internal Enable , if: <ul style="list-style-type: none"> • 24 V at X06.7 (AE) • no error 	–
	Multi-figure displays flash alternately.	
	Normal operating mode (NO) Standard operating display.	–
	Special operating mode (SO) Operating mode for open safety door where standstill monitoring of the drives is still active at maximum energy supply.	–
	Intermediate circuit not yet discharged Alternate flashing while DC link voltage > 50 V	Wait for a discharge time of 5 minutes and then check the DC link at the DC measuring sockets for zero voltage.







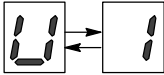
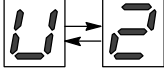
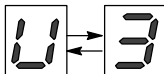
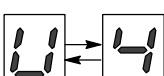
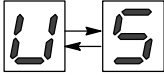

**DANGEROUS ELECTRICAL VOLTAGE**

Before dismantling the modules, wait for a discharge time of 5 minutes and check the DC link at the DC measuring sockets for zero voltage.

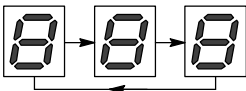
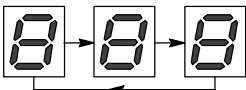
2.3 Warning displays VM..B,C,D

Indicators flash alternately	Warning	Action
	Overload Output limit of the VM reached during supply or regeneration: <ul style="list-style-type: none"> • $P_{\max} > 140\%$, or • $P_N > 100\%$ 	In continuous operation: reduce load When regenerating: flatten braking ramp by limiting braking current (P-0-0027)
	Overtemperature Heat sink temperature $> 75^{\circ}\text{C}$	<ul style="list-style-type: none"> • Check air supply • Check fans
	Overtemperature Ambient temperature $> 45^{\circ}\text{C}$	<ul style="list-style-type: none"> • Check operating conditions • Observe derating
	Power failure, 1-phase The VM maintains axis supply, although the output is reduced to 66 %. Overload may result if failure of one phase is long-term.	<ul style="list-style-type: none"> • Check fuses and line system • Check wiring • Replace power supply module NA
	Power failure, 2 or 3-phase $U_{\text{system rms}} < 70\%$ for more than 3 ms. The DC link can be temporarily supported by the axes, which are informed of the power failure via the module cross connection.	<ul style="list-style-type: none"> • Check fuses and line system • Check wiring • Replace power supply module NA

2.4 Status displays DM and DS (without frequency inverter)



LED	Status	Action
 FG	External Axis Enable , if <ul style="list-style-type: none"> 24 V at X06.3 (FG) 	–
 FGI	Internal Enable , if <ul style="list-style-type: none"> 24 V at X06.3 (FG) Central enable available via VM no error Additionally with SERCOS interface and CAN bus: "Drive-On" and "Drive-Enable" are available 	–
	Multi-figure displays flash alternately	
	Open ring (only with SERCOS interface and CAN bus) The preset address value flashes : <ul style="list-style-type: none"> before phase 0, if no signal was received from phase 2, if the axis was not addressed in phase 1 	<ul style="list-style-type: none"> in phase 0: check ring circuit from phase 2: check the setting of the axis address SERCOS interface : DIP switch on Personality Module CAN bus : rotary switches S2, S3 on front panel
	Phase 0 Initialization phase. If phase 0 has stopped: <ul style="list-style-type: none"> Error in phase start-up 	<ul style="list-style-type: none"> Check initialization file (*.scs) Contact control system manufacturer
	Phase 1 Initialization phase. If phase 1 has stopped: <ul style="list-style-type: none"> Error in phase start-up 	<ul style="list-style-type: none"> Check initialization file (*.scs) Contact control system manufacturer
	Phase 2 Initialization phase. If phase 2 has stopped: <ul style="list-style-type: none"> The parameters loaded into the drive during this phase are not all valid 	<ul style="list-style-type: none"> Request list of the invalid operating data phase 2 (S-0-0021) Check input limits of the parameters Check completeness of the parameters
	Phase 3 Initialization phase. If phase 3 has stopped: <ul style="list-style-type: none"> The parameters loaded into the drive during this phase are not all valid 	<ul style="list-style-type: none"> Request list of the invalid operating data phase 3 (S-0-0022) Check input limits of the parameters Check completeness of the parameters
	Phase 4 Operating phase The drive has started up, communication has been established.	–



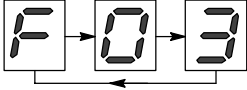
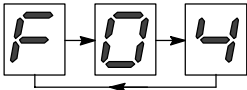
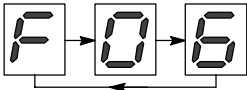
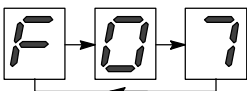
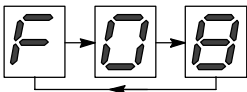
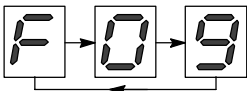
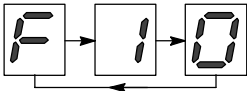
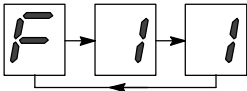
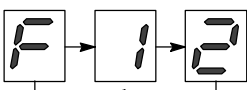
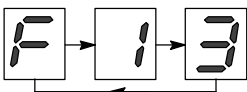
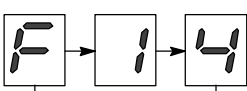

Phase run-up is performed so fast, especially if no bus interface is used, that the drive immediately displays phase 4 when it has been switched on.

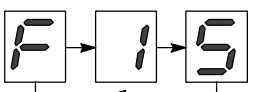
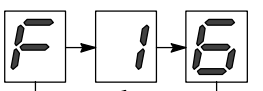
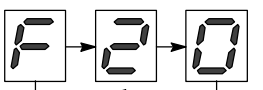
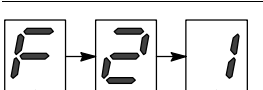
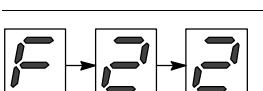
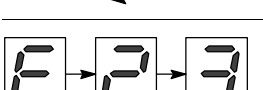
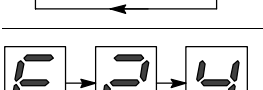
2.5 Error displays (without frequency inverter)

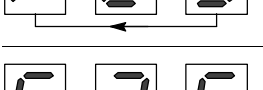
Displays flash alternately.	Error	Action
	Error in option module Option module in drive slot is faulty.	<ul style="list-style-type: none"> • Check option module has a stable position • Replace option module
	Overcurrent Permissible peak current exceeded.	<ul style="list-style-type: none"> • Reduce load • Flatten braking and acceleration ramps • Check controller optimisation • Check motor • Check application
	Real-time error Error in drive control system during commissioning	<ul style="list-style-type: none"> • Restart module • Reduce DSS-D load on CPU (e.g. turn oscilloscope off) • Replace module
	Module overtemperature Heat sink temperature > 80°C	<ul style="list-style-type: none"> • Increase air supply • Check fans
	Motor overtemperature Motor winding > 145°C, Temperature detector or detector circuit faulty.	<ul style="list-style-type: none"> • Reduce motor load, use larger motor • Check cooling • Check encoder cable • Check operating conditions
	Ambient overtemperature Ambient temperature > 55°C	<ul style="list-style-type: none"> • Check operating conditions • Observe derating
	Communication error SERCOS interface Only for modules with SERCOS interface terminal. Module jumps back to phase 0.	<ul style="list-style-type: none"> • After phase 2 start up, evaluate type of error and communication phase in which the error occurred (S-0-0014). Remove cause of error.
	Encoder error Connection error, short circuit or interruption of encoder cable. Encoder, encoder evaluation or electronic rating plate defective.	<p>With motor encoder and/or external encoder:</p> <ul style="list-style-type: none"> • Check encoder plug • Check encoder cable • Replace motor • Replace module
	Lag error, standstill monitoring axis moves without traverse command	<ul style="list-style-type: none"> • Check mechanics
	Excessive deviation of controller Drive could not follow the setpoint input.	<ul style="list-style-type: none"> • Compare max. setpoint input with spindle speed limit value (S-0-0091) • Check lag • SERCOS interface: Observe braking/acceleration current limit (P-0-0061, P-0-0062)
	Position limit value exceeded The predetermined setpoint leads to an axis position outside the travel range.	<ul style="list-style-type: none"> • Check position limit value parameters S-0-0049 and S-0-0050 • Check software limit switch settings

Displays flash alternately.	Error	Action
	<p>The drive has switched off.</p> <p>Normal mode: Maximum speed exceeded (channel 1)</p> <ul style="list-style-type: none"> The speed limit value S-0-0091 was exceeded. <p>Special mode (RSU): Deviation from Safe Standstill (channel 1)</p> <ul style="list-style-type: none"> The angle of rotation limit value P-0-0022 was exceeded. <p>Special mode with acknowledgement (RSU): Deviation from Safe Speed (channel 1)</p> <ul style="list-style-type: none"> The speed limit value P-0-0012 was exceeded. 	<ul style="list-style-type: none"> Observe speed limit value Observe sequence of operations Check enable signals Check control circuits Clear RSU error with "Control reset"
	<p>Normal mode: Maximum speed exceeded (channel 2)</p> <ul style="list-style-type: none"> The speed limit value S-0-0091 was exceeded. <p>Special mode (RSU): Deviation from Safe Standstill (channel 2)</p> <ul style="list-style-type: none"> The angle of rotation limit value P-0-0022 was exceeded. <p>Special mode with acknowledgement (RSU): Deviation from Safe Speed (channel 2)</p> <ul style="list-style-type: none"> The speed limit value P-0-0012 was exceeded. 	<ul style="list-style-type: none"> Observe speed limit value Observe sequence of operations Check enable signals Check control circuits Clear RSU error with "Control reset"
	<p>Charging circuit overloaded Energy loss in the charging resistors too high.</p>	<ul style="list-style-type: none"> Switch back on after approx. 5 min. Replace power supply module
	<p>Line reactor connection The line reactor is incorrectly connected.</p>	<ul style="list-style-type: none"> Check line reactor connection
	<p>Charging circuit defective Error in power supply module.</p>	<ul style="list-style-type: none"> Replace power supply module
	<p>No DC link controller DC link cannot be adjusted according to setpoint.</p>	<ul style="list-style-type: none"> Replace supply module
	<p>Main contactor does not pick up</p>	<ul style="list-style-type: none"> Replace power supply module
	<p>Main contactor released The main contactor was released during operation.</p>	<ul style="list-style-type: none"> Replace power supply module
	<p>Main contactor is not released</p>	<ul style="list-style-type: none"> Replace power supply module

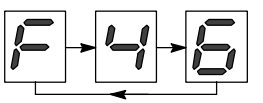
Displays flash alternately.	Error	Action
	Load contactor is not released	<ul style="list-style-type: none"> • Replace power supply module
	Synchronization error in VM..B,C,D	<ul style="list-style-type: none"> • Check mains voltage • Replace supply module
	Mains frequency Mains frequency < 48 Hz or > 62 Hz	<ul style="list-style-type: none"> • Check mains frequency
	Overvoltage in DC link DC link voltage > 670 V (before: U1 warning display)	<ul style="list-style-type: none"> • Reduce recovery capacity (Smooth down braking ramp, reduce braking current) • Note error message on VM
	Undervoltage in DC link DC link voltage < 670 V (before: U1 warning display)	<ul style="list-style-type: none"> • Reduce acceleration power of axes
	Overvoltage in mains Mains voltage > 456 V	<ul style="list-style-type: none"> • Check mains voltage
	Undervoltage in mains Mains voltage < 342 V	<ul style="list-style-type: none"> • Check mains voltage
	Error in Security Hardware	<ul style="list-style-type: none"> • Replace module
	24 V DC external fault 24 V module supply out of permissible range	<ul style="list-style-type: none"> • Check 24 V supply at X30 of the supply module • Check F1 miniature fuse in VM
	Drives do not stand still Drives shutdown not completed when time limit has expired	<ul style="list-style-type: none"> • Check time limit setting in VM • Check enable signals • Clear error with "Drive ON"
	Channel error Emergency-Stop Both channels were not switched within 0.5 sec	<ul style="list-style-type: none"> • Check Emergency-Stop wiring (X312.2, X06.3/4) • Clear error with "Drive ON"
	Channel error operating mode (RSU) Operating mode switchover via channels NO and SO does not take place within 0.5 sec.	<ul style="list-style-type: none"> • Check control of the VM inputs NO and SO (X312.3/4, X06.6) • Check safety door tumbler control • Clear error with "Drive ON"
	Channel error safety door tumbler (RSU) The check-back signal "safety door released" was not given within approx. 3 sec. in special mode	<ul style="list-style-type: none"> • Check safety door tumbler • Check PLC check-back signal (X312.6) • The VM should be replaced if there is a short-circuit in the driver of the safety door release (X312.5) • Clear error with "Drive ON"

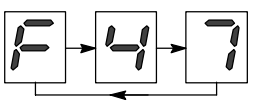
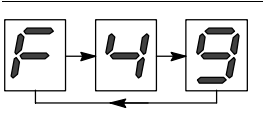
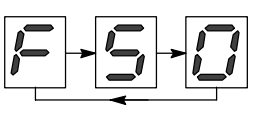
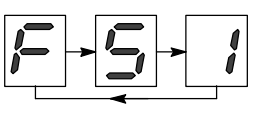
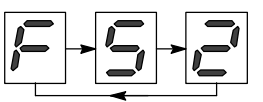
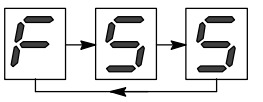
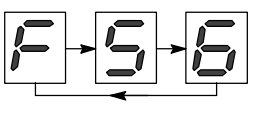
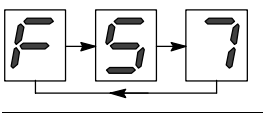
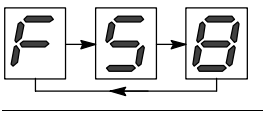
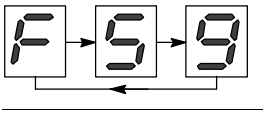
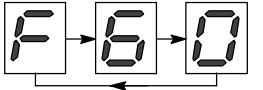
Displays flash alternately.	Error	Action
	Error The drive has switched off.	
	Error in special mode (RSU): Channel error Acknowledgement <ul style="list-style-type: none"> Both acknowledgement channels have not been operated within 1 sec (P-0-0024) Time limit P-0-0023 for acknowledgement exceeded Channel error "Safe signal transmission" Defective signal transmission in X810 starting with module with this error message Channel error "Safety-oriented data" The safety-oriented data on the PM module and in the EEPROM are not identical	<ul style="list-style-type: none"> Check wiring (X312.1, X06.5) Check key for mechanical or electrical bridge Observe sequence of operations Check X810 signal cross-connection Replace module Check safety-oriented data Clear error with "Control reset"
	Channel error FGZ (RSU) Defective transmission of the central enable signal from VM	<ul style="list-style-type: none"> Check X810 signal cross-connection Replace module
	Emergency Stop time step defective	<ul style="list-style-type: none"> Toggle 24 V off / on or press RESET Replace supply module
	CPU test Error in microprocessor.	<ul style="list-style-type: none"> Replace module
	RAM test Error in RAM memory.	<ul style="list-style-type: none"> Replace module
 up to 	Checksum error	<ul style="list-style-type: none"> Replace personality module or memory card
	Update Memory Card Update of memory card was incorrect.	<ul style="list-style-type: none"> Replace memory card
	Watchdog-Test	<ul style="list-style-type: none"> Replace module
	Error in security test	<ul style="list-style-type: none"> Replace module
	Memory overflow	
	Initialization error I²C-bus	<ul style="list-style-type: none"> Replace module

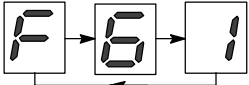
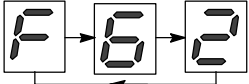
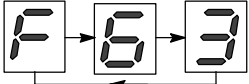
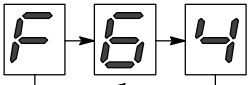
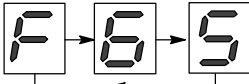
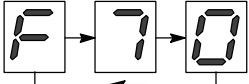
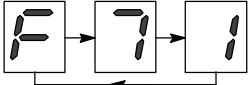
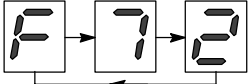
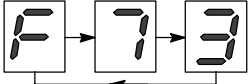
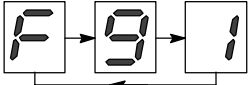
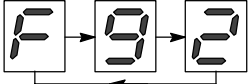
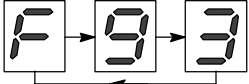
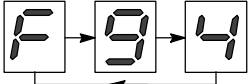
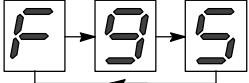
Displays flash alternately.	Error	Action
	Initialization error AD converter The drive has switched off.	<ul style="list-style-type: none"> • Check motor lead • Replace module
	Initialization error PWM3	<ul style="list-style-type: none"> • Replace module
	Initialization error SERCOS tables	<ul style="list-style-type: none"> • Replace module
	Initialization error overcurrent threshold	<ul style="list-style-type: none"> • Replace module
	Initialization error Security (RSU)	<ul style="list-style-type: none"> • Check signal cross-connection between modules • Replace module
	Encoder error Incorrect encoder initialization	<ul style="list-style-type: none"> • Connect suitable encoder • Check encoder connection • Replace motor/encoder
	Invalid driver identification	<ul style="list-style-type: none"> • Replace module
	Assignment module – software Software and hardware are not compatible.	<ul style="list-style-type: none"> • Use compatible software
	Assignment power supply module – VM Power supply module and supply module do not have the same power output stage.	<ul style="list-style-type: none"> • Combine compatible modules
	Runtime Personality Module	<ul style="list-style-type: none"> • Check stable position of personality module • Replace personality module
	Runtime I²C-bus	<ul style="list-style-type: none"> • Replace module
	Stack error	<ul style="list-style-type: none"> • Replace module
	Unpermitted memory access	<ul style="list-style-type: none"> • Replace module
	Synchronisation I-controller	<ul style="list-style-type: none"> • Replace module

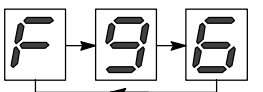
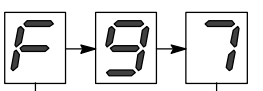
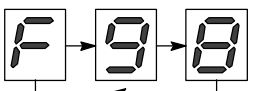
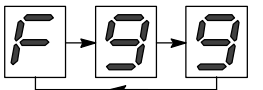

Displays flash alternately.	Error The drive has switched off.	Action
	Speed controller plausibility error	<ul style="list-style-type: none"> ● Check motor lead ● Check DC link voltage ● Check DC link connection of modules (for DM..A,B,C in backplanes). Switch modules off because of dangerous electrical voltage! ● Motor stalled ● Switch off torque reduction ● For details, refer to P-0-0010
	VM shut-down Shut-down due to operation error (e.g. undervoltage/overvoltage)	<ul style="list-style-type: none"> ● Check error message on VM ● Clear error with "Control reset"
	VM shut-down Shut-down due to shut-down command	<ul style="list-style-type: none"> ● Switch VM on ● Check Emergency-Stop
	Other runtime errors	<ul style="list-style-type: none"> ● Replace module

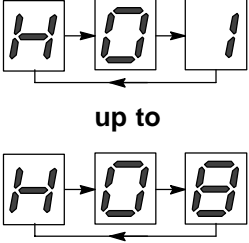
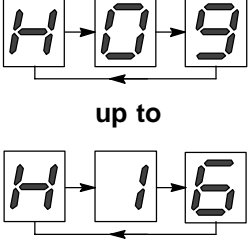
2.6 DM computer errors (without SERCOS interface)

Displays flash alternately.	Error	Action
	<p>CPU program execution errors</p> <p>H01 non-maskable interrupt H02 stack overflow H03 stack underflow H04 undefined CPU code H05 undefined protected command H06 inadmissible word instruction H07 inadmissible jump H08 inadmissible bus control</p>	<ul style="list-style-type: none"> • Contact Bosch technical service • Replace module
	<p>CPU computing errors</p> <p>H09 integer overflow H10 floating overflow H11 floating underflow H12 division by zero H13 undefined floating number H14 integer/floating conversion error H15 floating point stack overflow H16 floating point stack underflow</p>	<ul style="list-style-type: none"> • Check last parameter changes made before error occurred • Contact Bosch technical service

2.7 Servodyn-D frequency inverter displays

2.7.1 Status/warning displays

LED	Status	Action
 FG	External Axis Enable , if <ul style="list-style-type: none"> • 24 V at X06.3/4 (FG) 	–
 FGI	Internal Enable , if <ul style="list-style-type: none"> • 24 V at X06.3 (FG) • Central enable available via VM • no error 	–





3-digit 7-segment display

 <p>Computer has run up TEMP STA</p>	<p>Operating display:</p> <ul style="list-style-type: none"> • STA is present if <ul style="list-style-type: none"> – computer has run up – no error <p>Temperature warning:</p> <ul style="list-style-type: none"> • TEMP is present if: warning temperature of the heat sink or the motor (with active bimetal function) is exceeded. • TEMP relay is opened 	<p>–</p> <ul style="list-style-type: none"> • Check air supply, fans • Reduce cycle frequency or load • Select higher motor rating • Check bimetal setting
---	--	--

You can read various operating data from the 7-segment display:

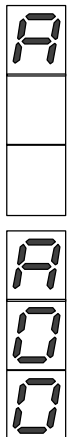







- Press <D> key in the basic display
- Select the 'A' display function with the <↑> or <↓> keys.
- Press <D>.
- Select the desired operating display with the <↑> or <↓> keys, e.g. A00 (actual output frequency).
- Press <D>.
- The display shows the current operating data.
- Jump back to the operating data level with the <PgUp> keys.
- You may now select the next operating display with the <↑> or <↓> key, e.g. A08.
- Further procedure as described above.



	Unit	Description	
A00	Hz	Actual output frequency f_{act}	Current motor frequency
A01	Hz	Commanded output frequency f_{set}	Specified output frequency
A02	A	Total current	rms value of the total current
A03	A	Active current	rms value of active current
A04	A	Reactive current	rms value of reactive current
A05	V	Motor voltage	rms value of current motor voltage
A06	V	DC link voltage	Current value of the DC link voltage. For range, see "Interface conditions" manual.

	Unit	Description	
A07	kVA	Total power	Current total power
A08	kW	Shaft output	Current mechanical shaft output of the motor
A09	%	Utilization	Current utilization rate of the motor, for $f < f_N$ with reference to the motor torque M_N for $f > f_N$ with reference to the motor power P_N Accuracy: depends on motor, for $n > 0.1 n_N$, approx. 5% of final value
A10	°C	Heat sink temperature	Current heat sink temperature. Warning message 'U01' with excessive heat sink temperature, TEMP relay opens.
A11	A	Present current limit	The presently effective current limit is set depending on the selected settings and the current heat sink temperature.
A12		TEMP warning	Warning message when TEMP relay has switched off:
		U00	no warning
		U01	excessive heat sink temperature
		U02	excessive motor temperature. Only if bimetal function is active P43 – P45.
		U03	excessive heat sink and motor temperature
A13		Last error after STA shut-off	The last error prior to STA shut-off is displayed when unit is switched back on.
A14		Software version	Number left of dot = software version Number right of dot = software scope Always specify both numbers in enquiries
A15		Software index	Version index of operating software, always specify in enquiries.

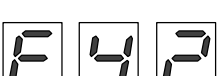
2.7.2 Error displays

Displays arranged vertically on module	Error	Action
	Power supply fault Internal supply voltages not in admissible range	<ul style="list-style-type: none"> • Check module cross-connections • Replace module
	Overvoltage / driver fault Drivers were switched off due to a supply module fault	<ul style="list-style-type: none"> • Check output stage • Replace module
	Short-circuit or earth fault in load circuit Motor or motor lead defective	<ul style="list-style-type: none"> • Measure motor and motor lead • Check output stage
	Overcurrent Admissible module peak current exceeded for > 2 sec	<ul style="list-style-type: none"> • Reduce load • Flatten braking and acceleration ramps • Check application
	Overvoltage in DC link $U_{DC} > 860 \text{ V}$, unless F20	<ul style="list-style-type: none"> • Check system voltage • Reduce braking power
	Motor connection Motor not properly connected	<ul style="list-style-type: none"> • Check motor connection
	Heat sink overtemperature	<ul style="list-style-type: none"> • Check air supply • Check fans
	Motor overtemperature Electronic bimetal function signals motor overload	<ul style="list-style-type: none"> • Check bimetal setting • Check motor rating
	RAM memory error	<ul style="list-style-type: none"> • Replace module
	EEPROM error Reading from and/or writing to the EEPROM not possible	<ul style="list-style-type: none"> • Replace module
	Incorrect software Software not valid for this module size	<ul style="list-style-type: none"> • Use valid software • Check software index
 up to 	Real-time error Control unit error	<ul style="list-style-type: none"> • Restart module • Replace module

3 Connection overview

3.1 Supply module VM..K

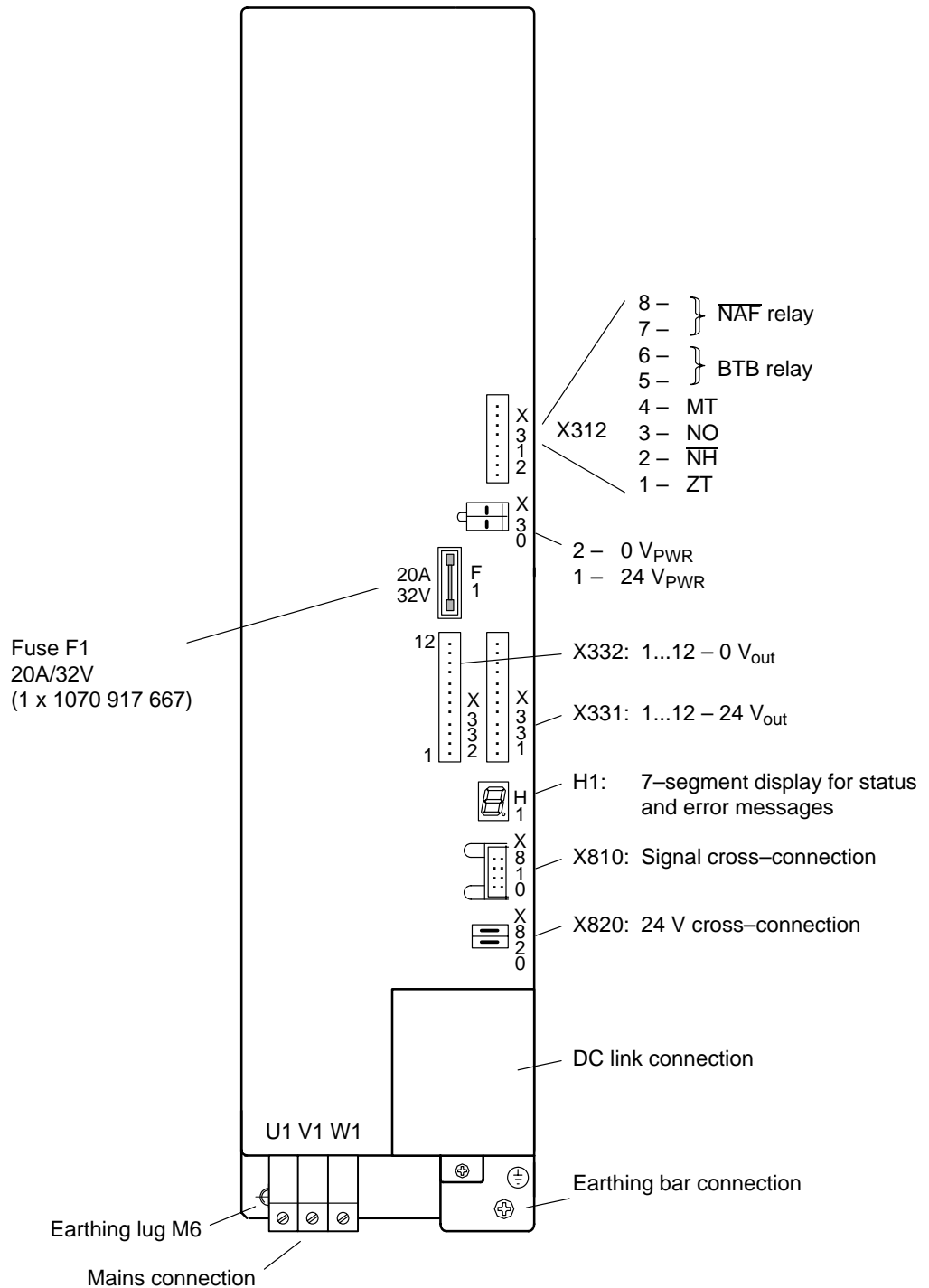

3.2 Supply module VM..B,C,D

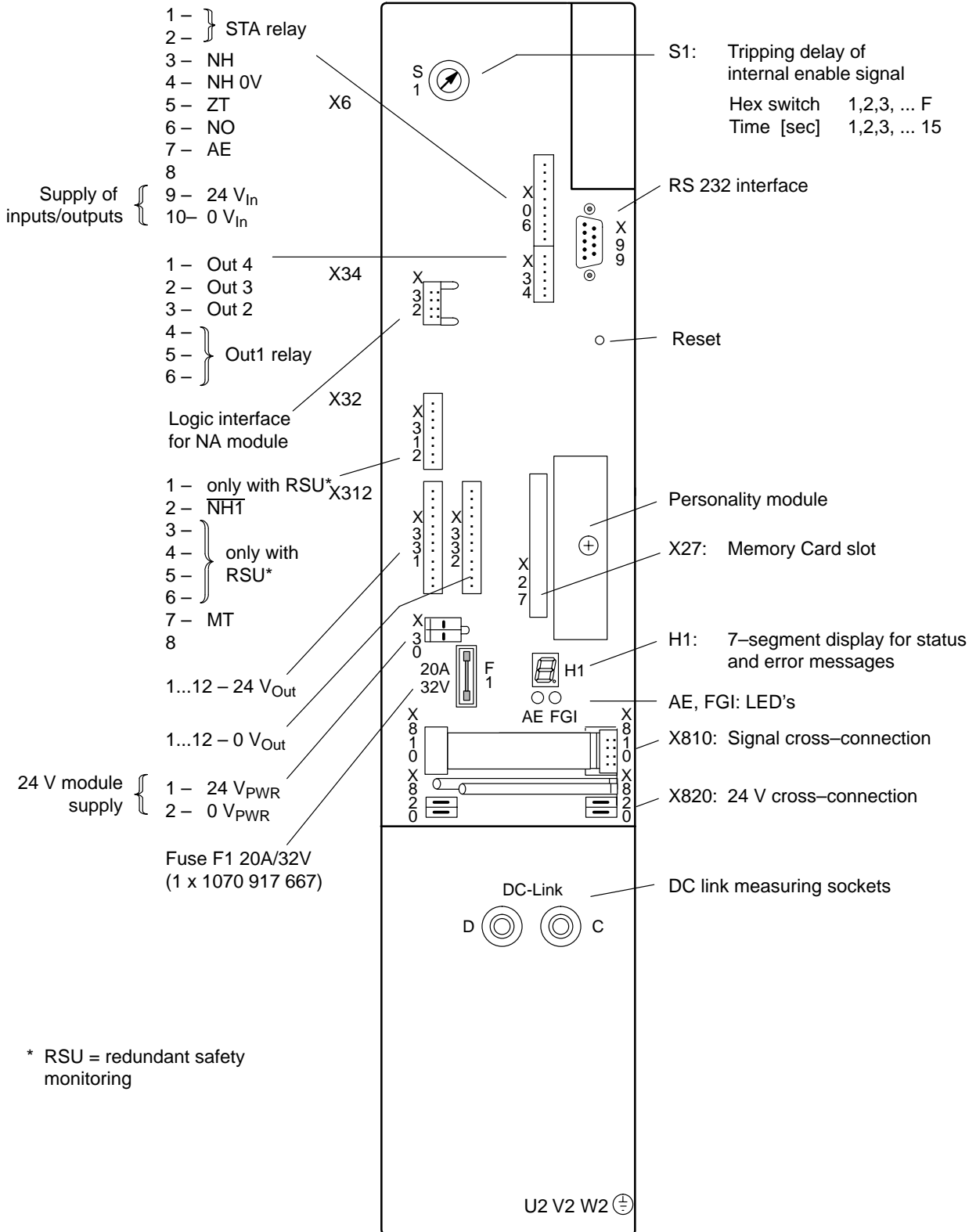

* RSU = redundant safety monitoring

3.3 Three-phase current module DM with analog interface or positioning function

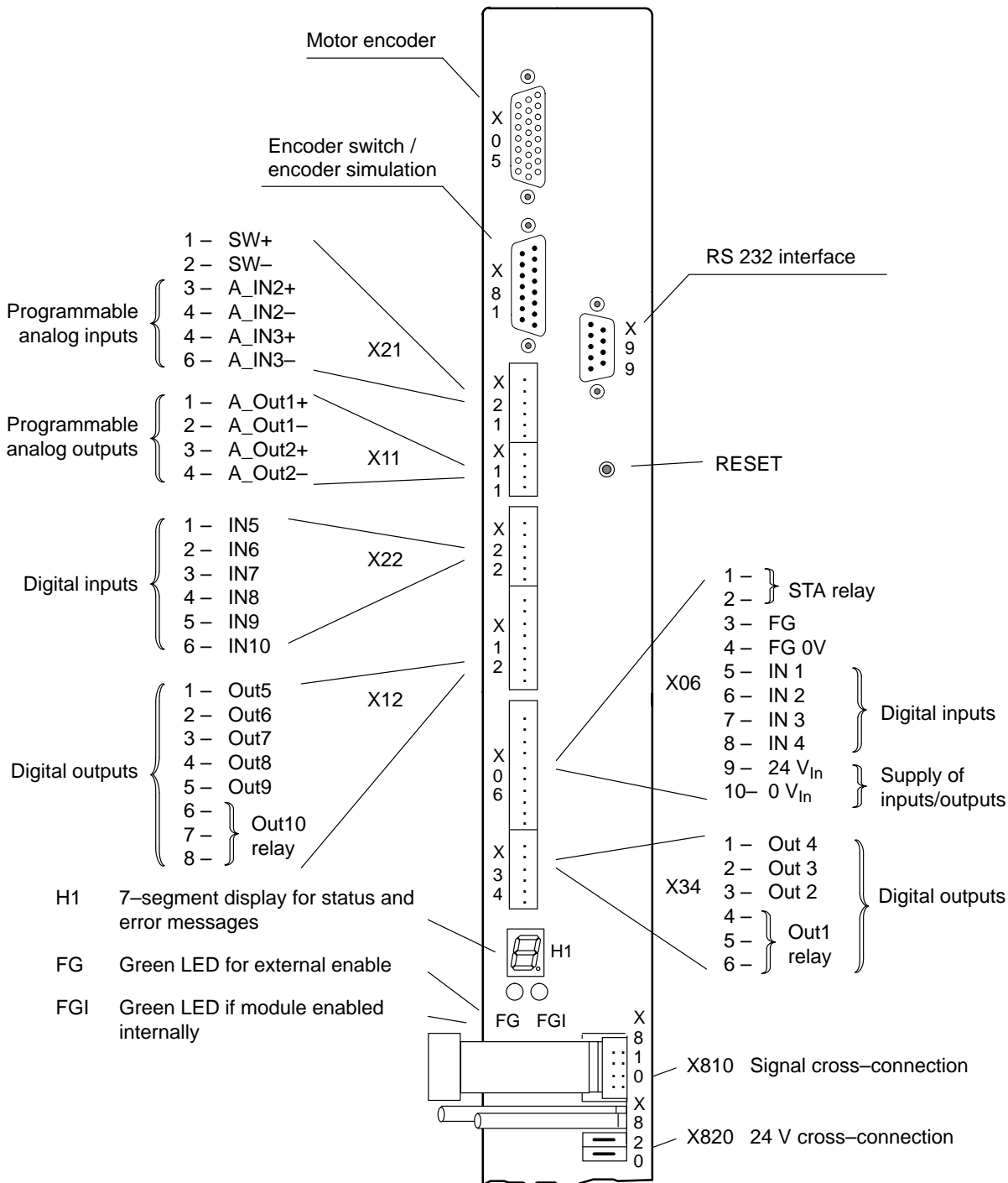

3.5 Three-phase current module DM with CAN bus

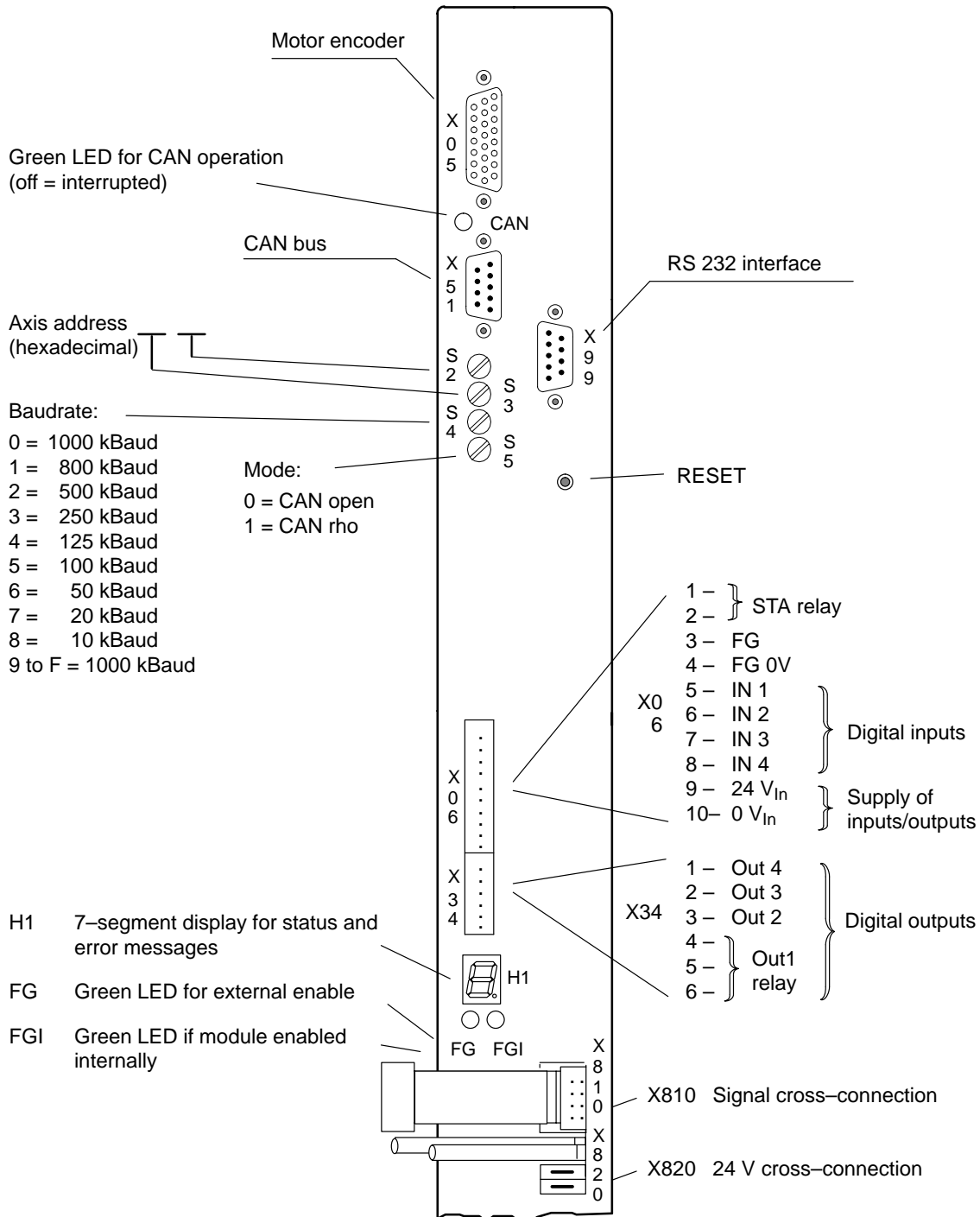

3.6 Three-phase current module DM with SERCOS interface

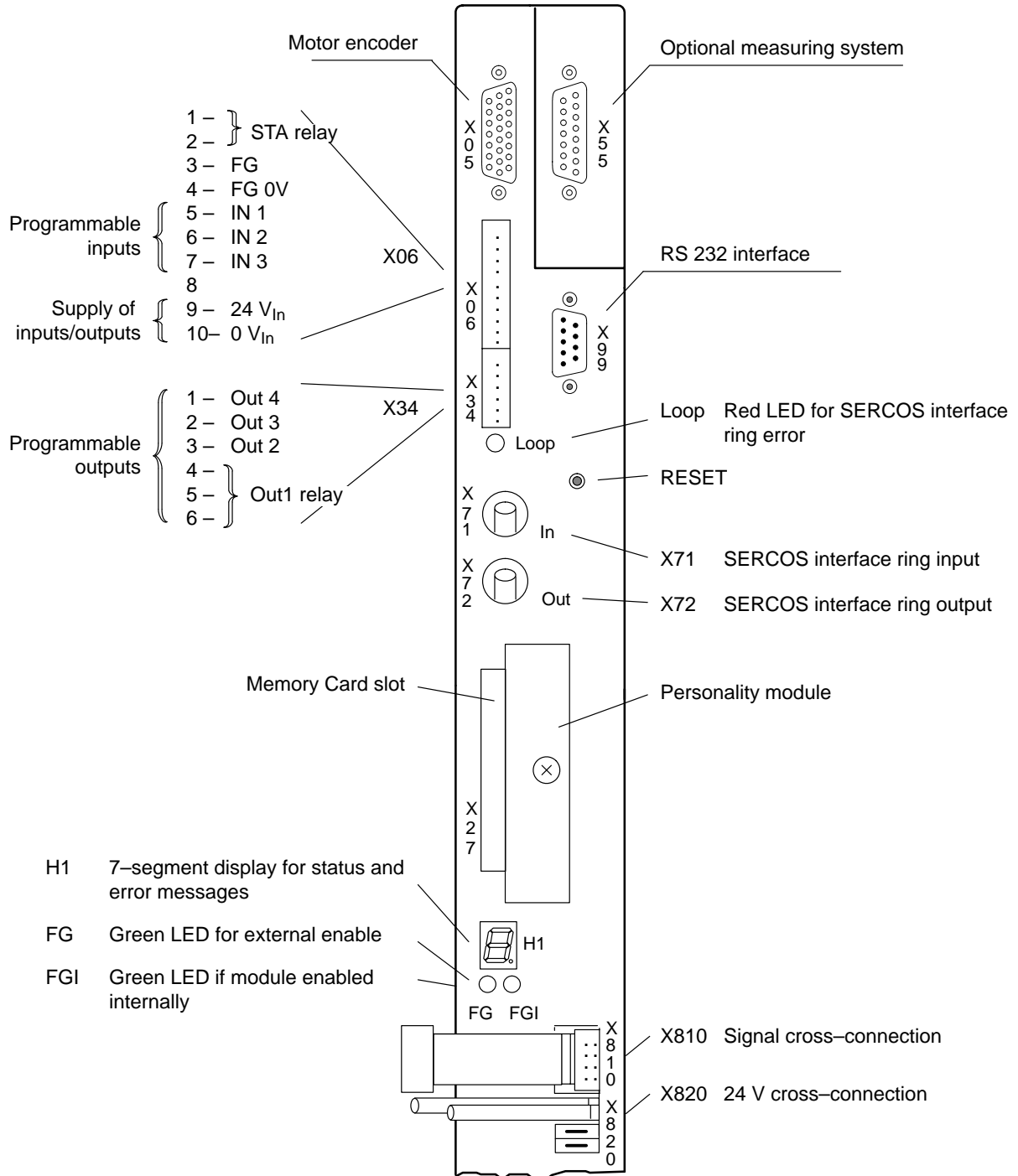

3.7 Stand-alone module DS, supply unit

Stand-alone modules are single-axis drives with an integrated supply unit. The interfaces and functions correspond to those of the modules described in sections 3.3 to 3.6.

Therefore, the following illustration only shows the additional connectors of the supply unit:

- Other connectors corresponding to the interfaces:
- analog interface, positioning function
 - frequency inverter
 - CAN bus
 - SERCOS interface

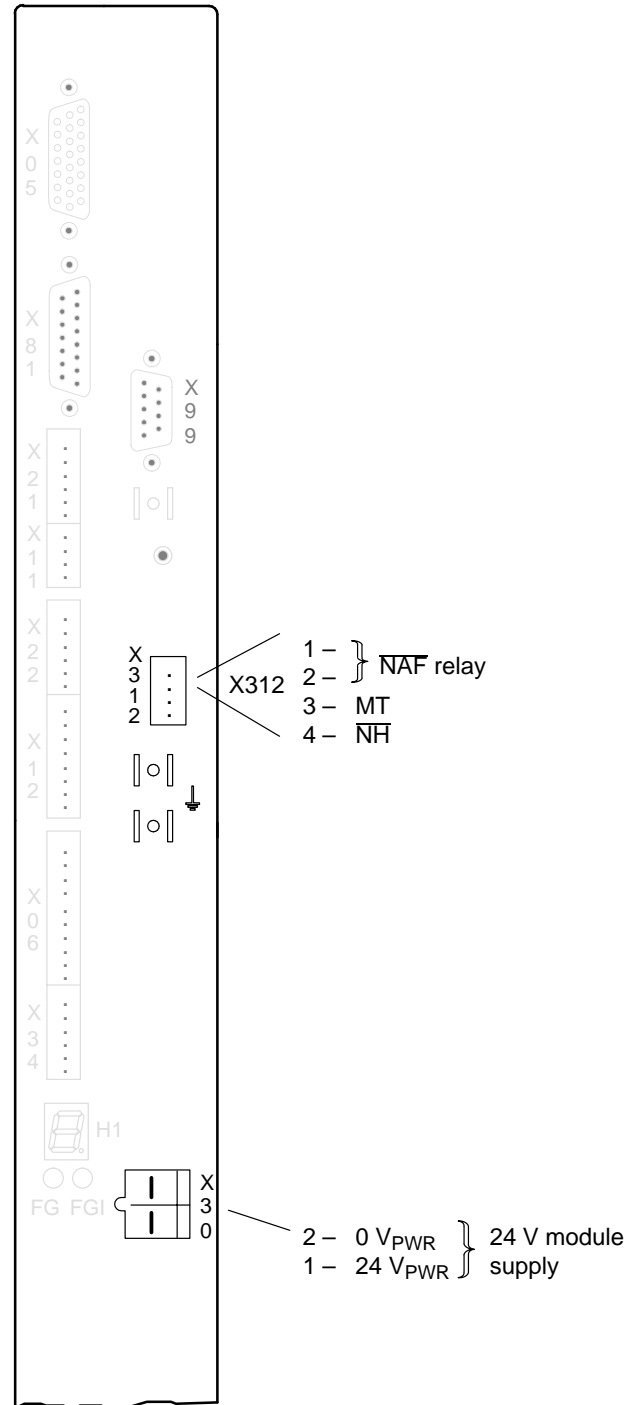

Your notes:

4 Replacing components

**DANGER**

Danger caused by unqualified interventions.

The maintenance and installation of the components is reserved to qualified personnel who observes the accident prevention regulations (UVV VBG4, VDE 100, VDE 105) and installation standards (EN 60204-Part 1, prEN 50178).

Please note the safety instructions on the first pages of this manual!



If a defective drive component is to be replaced, please use our 'Diagnostics card' to facilitate diagnostics and handling.

4.1 Motors

**DANGER**

Brakes are subject to wear.

The holding brake is no service brake and must only be operated when the axis is at standstill.

After approx. 1000 Emergency-Stop braking processes with an extraneous moment of inertia \leq motor moment of inertia, the holding brake must be checked in the manufacturer's workshop.

**DANGEROUS ELECTRICAL VOLTAGE**

All connection and installation work must be performed while the system is de-energized.

Due to permanent magnet excitation, a dangerous voltage is present at the power outlet when the rotor is rotating and the motor is not connected electrically!

**DANGER**

Danger of injuries by ejected featherkey.

Motors with a groove and featherkey may only be operated when installed in place or with featherkey secured.

**CAUTION**

Hitting or knocking on the shaft end will damage the rotary encoder and the ball bearing!

Drive elements such as pulleys, clutch disks, toothed gears etc. must be installed or removed after steady warming-up of the drive elements to 60 or 80 °C or with a suitable installation or dismantling tool. Use the thread at the shaft end.

At least half of motors with an **oil-tight flange on the output side** (oil-running tight, designs 100, 101) must be submerged in oil. Due to the high friction, they must never be started dry.

For dry operation, the rotary shaft seal must be removed, however, it cannot be reinstalled afterwards.

**CAUTION**

Loss of data!

Interventions in the motor may delete the data of the electronic rating plate.

Do not dismantle servo motors. Installation work in excess of the adjustment of the outgoing cable direction must be performed in the manufacturer's workshop.

The outgoing direction of all plug-in systems can be changed by releasing the angle flange box.

Do not turn the angle flange box by more than 180° in order to avoid damaging the connection leads.

**CAUTION**

Moisture inside the motor.

When tightening the angle flange box, please make sure that the O-ring is properly seated in the groove of the angle flange box.

Protection standard IP 67 is achieved for the plug-in system only if the admissible external lead diameters are maintained and the mating connectors are screwed down to their stop.

4.2 Drive modules



CAUTION

Destruction of supply modules!

Note the tightening torque of 3 Nm for the power connections U, V, W.

4.2.1 DC link connection of VM..B,C,D and DM..A,B,D with backplane modules

The conductor bars are captivated in the backplane module terminal blocks. Mounting using a SW 4 Allen key:

1. Unscrew the terminal screws (1).
2. Unscrew the terminal screws (2), move the conductor bars into the adjoining terminal block and tighten the screws.
3. Fasten the second end of the conductor bar using the terminal screw (1).
4. Cover the right backplane module terminal block of every module row with the terminal block end cover from the VM module accessory set. There is a second cover in the DC link terminal accessory set which can be used if there are two module rows.



DANGEROUS ELECTRICAL VOLTAGE

Busbars carry lethal voltages during operation.

It is absolutely necessary to install the terminal block covers at the right-hand end of each row of modules.

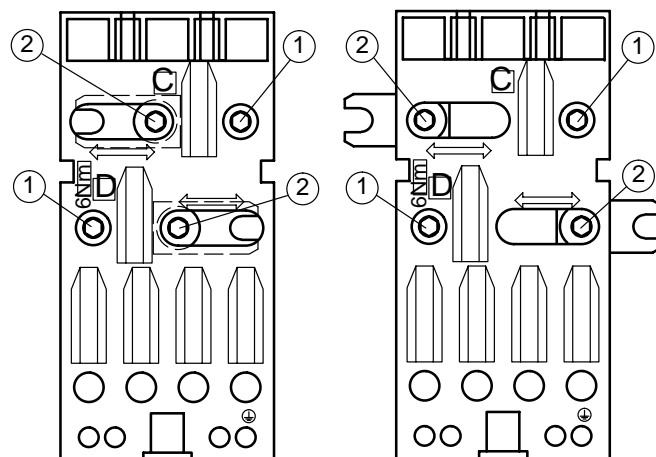

CAUTION

Destruction of supply modules!

Please note the tightening torque of 6 Nm for the screwed DC link connections.

4.2.2 VM...K and DM...K

The DC link connection is achieved with conductor bars "C" and "D" at the front side of the modules:

1. Release fastening screw below the cover, unhinge and remove cover upward.
2. Release screws of the pre-assembled conductor bars, push bars below the fastening screws of the adjoining left module, and tighten screws again.

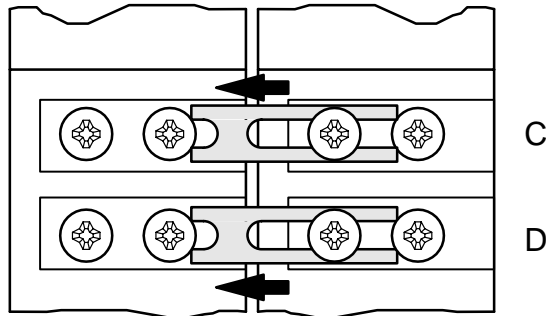

CAUTION

Destruction of supply modules!

Please note the tightening torque of 3 Nm for the screwed DC link connections.

3. Reinstall all covers.



DANGEROUS ELECTRICAL VOLTAGE

Busbars carry lethal voltages during operation.

It is absolutely necessary to install the shock-protection covers at both ends of each row of modules.

A Appendix

C

- Computer errors, 2–11
- Connection overview
 - Frequency inverter with analog interface, 3–4
 - Stand-alone module DS, 3–7
 - Supply module VM..B,C,D, 3–2
 - Supply module VM..K, 3–1
 - Three-phase current module with analog interface, 3–3
 - Three-phase current module with CAN bus, 3–5
 - Three-phase current module with positioning function, 3–3
 - Three-phase current module with SERCOS interface, 3–6

D

- DC link connection
 - compact mechanics without backplane modules, 4–4
 - with backplane modules, 4–3
- Documentation, XIII

E

- e.l.c.b., 1–1
- EMC directive, VII
- EMERGENCY–STOP devices, XII
- Error displays
 - all without frequency inverter, 2–5
 - Computer errors, 2–11–2–14
 - Frequency inverter, 2–14
- ESD, Electrostatic discharge, XI
- ESD-sensitive components, XI, XII

H

- Holding brake, 4–1

I

- IT system, 1–1

L

- Low-voltage directive, VII

M

- Machine directive, VII
- Mains connection, 1–1
- Modifications, X
- Modules sensitive to electrostatic discharge. *See* ESD-sensitive components

P

- Proper use, VII

Q

- Qualified personnel, VIII

R

- Replacement parts, XII
- Replacing components
 - Drive modules, 4–3
 - Motors, 4–1

S

- Safety instructions, X
- Safety markings, IX
- Spare parts, XII
- Status displays
 - Frequency inverter, 2–12
 - Stand-alone module DS, 2–4
 - Supply module VM...B,C,D, 2–2
 - Supply module VM...K, 2–1
 - Three-phase module DM, 2–4

T

- Test activities, XI
- Tightening torque
 - DC link in backplane modules, 4–3
 - DC link in compact mechanics, 4–4
 - Power connections, 4–3
- TT protective system, 1–1

W

- Warning displays
 - Frequency inverter, 2–12
 - VM..B,C,D, 2–3

Your notes:

Bosch-Automationstechnik

Robert Bosch GmbH
Geschäftsbereich
Automationstechnik
Industriehydraulik
Postfach 30 02 40
D-70442 Stuttgart
Telefax (07 11) 8 11-18 57

Robert Bosch GmbH
Geschäftsbereich
Automationstechnik
Fahrzeughydraulik
Postfach 30 02 40
D-70442 Stuttgart
Telefax (07 11) 8 11-17 98

Robert Bosch GmbH
Geschäftsbereich
Automationstechnik
Pneumatik
Postfach 30 02 40
D-70442 Stuttgart
Telefax (07 11) 8 11-89 17

Robert Bosch GmbH
Geschäftsbereich
Automationstechnik
Montagetchnik
Postfach 30 02 07
D-70442 Stuttgart
Telefax (07 11) 8 11-77 12

Robert Bosch GmbH
Geschäftsbereich
Automationstechnik
Antriebs- und Steuerungstechnik
Postfach 11 62
D-64701 Erbach
Telefax (0 60 62) 78-4 28

Robert Bosch GmbH
Geschäftsbereich
Automationstechnik
Schraub- und Einpreßsysteme
Postfach 11 61
D-71534 Murrhardt
Telefax (0 71 92) 22-1 81

Robert Bosch GmbH
Geschäftsbereich
Automationstechnik
Entgrattechnik
Postfach 30 02 07
D-70442 Stuttgart
Telefax (07 11) 8 11-34 75

Technische Änderungen vorbehalten

Ihr Ansprechpartner

BOSCH



Robert Bosch GmbH
Geschäftsbereich
Automationstechnik
Antriebs- und Steuerungstechnik
Postfach 11 62
D-64701 Erbach
Telefax (0 60 62) 78-4 28