

ACCU ELECTRIC MOTORS INC

USA: (888) 932-9183

CANADA: (905) 829-2505

- ✓ Over 100 years cumulative experience
- ✓ 24 hour rush turnaround / technical support service
- ✓ Established in 1993



The leading independent repairer of servo motors and drives in North America.

Visit us on the web:

www.servo-repair.com

www.servorepair.ca

www.ferrocontrol.com

www.sandvikrepair.com

www.accuelectric.com

Scroll down to view your document!

For 24/7 repair services :

USA: 1 (888) 932 - 9183

Canada: 1 (905) 829 -2505

Emergency After hours: 1 (416) 624 0386

Servicing USA and Canada



ELECTRIC MOTORS, GEARMOTORS AND DRIVES

Variable Speed AC Motor Drives

**SM-Basic
Installation and Operation Manual**

LEESON ELECTRIC CORPORATION

2100 WASHINGTON STREET GRAFTON, WI 53024-0241 (262)377-8810 FAX: (262)377-9025

EC Declaration of Conformity In accordance with EN45014:1998

We,

Leeson Electric Corporation
2100 Washington Street
Grafton, Wisconsin 53024
USA

declare under sole responsibility that the following equipment to which this declaration relates, meets the essential health and safety requirements and is in conformity with the relevant sections of the applicable EC standards and other normative documents. If changes are made to the product that is covered by this declaration of conformity, the declaration of conformity is no longer valid.

Equipment Type:

AC Variable Frequency Motor Drives:

174374.00	174375.00	174376.00	174377.00	174378.00
174379.00	174380.00	174381.00	174382.00	174383.00
174384.00	174385.00	174386.00	174387.00	174388.00

EC Directives:

By virtue of this conformity, the products are deemed to comply with the provisions of the Council of European Communities Directives listed, provided installations are carried out in accordance with the manufacturer's instructions.

- 1) Low Voltage Directive 73/23/EEC as amended 93/68/EEC
- 2) Electromagnetic Compatibility Directive 89/336/EEC as amended 92/31/EEC

Harmonized Standards Used:

EN50081-2*: Electromagnetic Compatibility — Generic Emission Standard; Part 2: Industrial Environment
EN50082-2*: Electromagnetic Compatibility — Generic Emission Standard; Part 2: Industrial Environment
EN50178; 1998 Electronic Equipment for use in Power Installations

* with suitable filters that are properly installed

Authorized Representative:

Ms. Elisa Basso
Leeson Electric International
Via Caduti Di Sabbiano 11/D-E
40011 Anzola Emilia Bologna
Italy

Phone: (+39) 0-51-732-247

Fax: (+39) 0-51-734-943

Dated this 2nd day of May 2000.



Peter F. Hennig
Senior Design Engineer



TABLE OF CONTENTS

1.0	GENERAL	1
2.0	SM-Basic DIMENSIONS	2
3.0	SM-Basic MODEL DESIGNATION CODE	3
4.0	SM-Basic SPECIFICATIONS	3
5.0	SM-Basic RATINGS	4
6.0	INSTALLATION	5
7.0	INPUT AC POWER REQUIREMENTS	7
8.0	POWER WIRING	8
9.0	SM-Basic POWER WIRING DIAGRAM	9
10.0	CONTROL WIRING	10
11.0	SM-Basic CONTROL WIRING DIAGRAMS	13
12.0	INITIAL POWER UP AND MOTOR ROTATION	16
13.0	PROGRAMMING THE SM Basic DRIVE	18
14.0	PARAMETER MENU	21
15.0	DESCRIPTION OF PARAMETERS	23
16.0	TROUBLESHOOTING	37
17.0	SM-Basic DISPLAY MESSAGES	39
18.0	USER SETTING RECORD	41

THE SM-Basic SUB-MICRO DRIVE

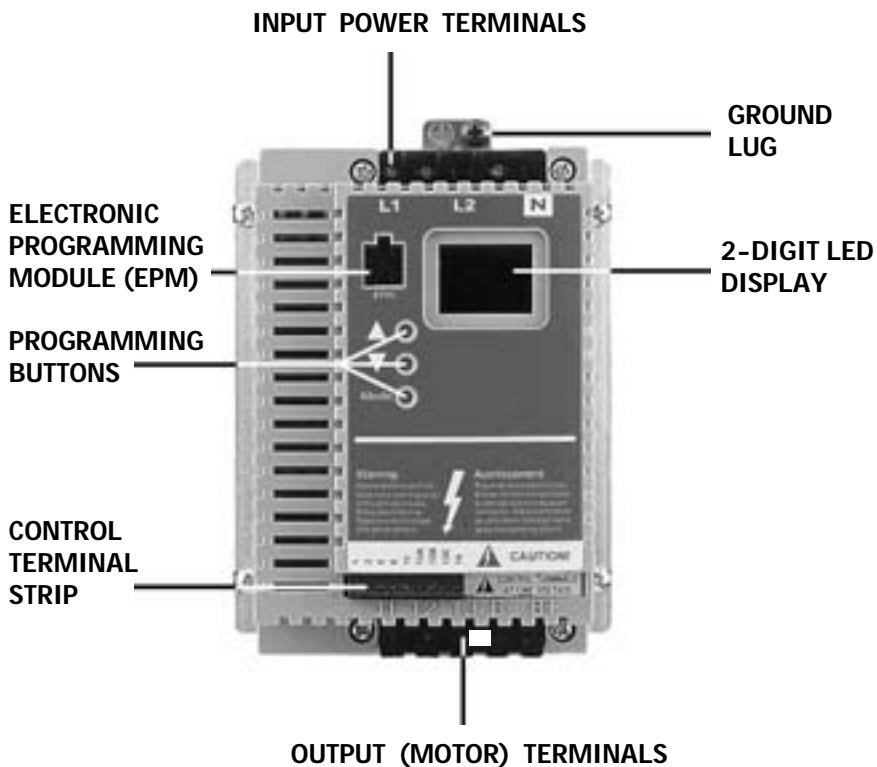

1.0 GENERAL

1.1 PRODUCTS COVERED IN THIS MANUAL

This manual covers the Leeson Electric Corporation SM-Basic Series Variable Frequency Drive.

1.2 PRODUCT CHANGES

Leeson Electric Corporation reserves the right to discontinue or make modifications to the design of its products without prior notice, and holds no obligation to make modifications to products sold previously. Leeson Electric Corporation also holds no liability for losses of any kind which may result from this action.

1.3 WARRANTY

Leeson Electric Corporation warrants the SM-Basic AC motor control to be free of defects in material and workmanship for a period of twelve months from the date of sale to the user, or eighteen months from the date of shipment, whichever ever occurs first. If an SM-Basic motor control, under normal use, becomes defective within the stated warranty time period, contact Leeson Electric's Service Department for instructions on obtaining a warranty replacement unit. Leeson Electric Corporation reserves the right to make the final determination as to the validity of a warranty claim, and sole obligation is to repair or replace only components which have been rendered defective due to faulty material or workmanship. No warranty claim will be accepted for components which have been damaged due to mishandling, improper installation, unauthorized repair and/or alteration of the product, operation in excess of design specifications or other misuse, or improper maintenance. Leeson Electric Corporation makes no warranty that its products are compatible with any other equipment, or to any specific application, to which they may be applied and shall not be held liable for any other consequential damage or injury arising from the use of its products.

This warranty is in lieu of all other warranties, expressed or implied. No other person, firm or corporation is authorized to assume, for Leeson Electric Corporation, any other liability in connection with the demonstration or sale of its products.

1.4 RECEIVING

Inspect all cartons for damage which may have occurred during shipping. Carefully unpack equipment and inspect thoroughly for damage or shortage. Report any damage to carrier and/or shortages to supplier. All major components and connections should be examined for damage and tightness, with special attention given to PC boards, plugs, knobs and switches.

1.5 CUSTOMER MODIFICATION

Leeson Electric Corporation, its sales representatives and distributors, welcome the opportunity to assist our customers in applying our products. Many customizing options are available to aid in this function. Leeson Electric Corporation cannot assume responsibility for any modifications not authorized by its engineering department.

2.0 SM-Basic DIMENSIONS

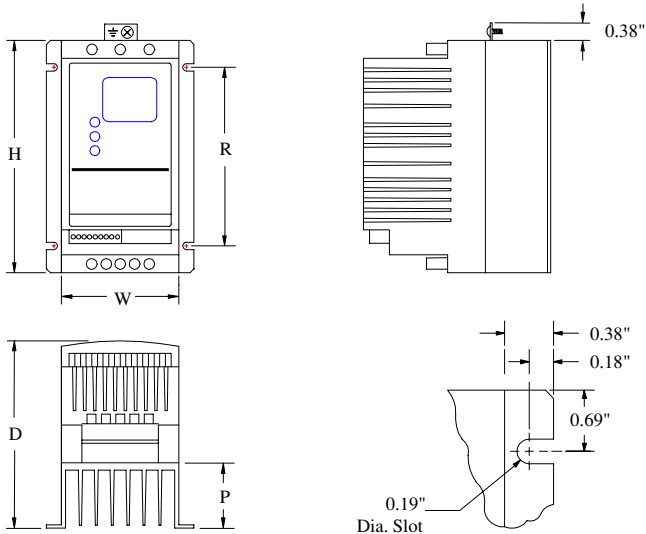

Mounting Tab Detail

HP	INPUT VOLTAGE	MODEL	H	W	D	P	R
0.25	120/208/240	174374	5.75	2.88	3.76	0.80	4.37
	208/240	174378	5.75	2.88	3.76	0.80	4.37
0.5	120/208/240	174375	5.75	2.88	3.76	0.80	4.37
	208/240	174379	5.75	2.88	3.76	0.80	4.37
	400/240	174384	5.75	2.88	3.76	0.80	4.37
1	120/208/240	174376	5.75	3.76	5.24	1.90	4.37
	400/480	174380	5.75	2.88	4.56	1.60	4.37
	480/590	174385	5.75	2.88	4.56	1.60	4.37
1.5	120/208/240	174445	5.75	3.76	5.24	1.90	4.37
	208/240	174381	5.75	3.76	5.24	1.90	4.37
	208/240	174386	5.75	2.88	5.56	2.60	4.37
2	208/240	174382	5.75	3.76	5.24	1.90	4.37
	208/240	174387	5.75	2.88	5.56	2.60	4.37
3	208/240	174383	5.75	3.76	6.74	3.40	4.37
	208/240	174388	5.75	3.76	6.74	2.60	4.37

3.0 SM-Basic MODEL DESIGNATION CODE

4.0 SM-Basic SPECIFICATIONS

Storage Temperature	-20 to 70 C
Ambient Operating Temperature	0 to 50 C (up to 6 kHz carrier, derate above 6 kHz)
Ambient Humidity	< 95% (non-condensing)
Altitude	3300 ft (1000 m) above sea level (without derating)
Input Line Voltages	120/208/240 Vac single phase, 208/240 Vac three phase
Input Voltage Tolerance	+10%, -15%
Input Frequency Tolerance	48 to 62 Hz
Output Wave Form	Sine Coded PWM
Output Frequency	0 - 99 Hz
Carrier Frequency	4 kHz to 10 kHz
Service Factor	1.00 (up to 6 kHz carrier, derate above 6 kHz)
Efficiency	Up to 98%
Power Factor (displacement)	0.96 or better
Overload Current Capacity	150% for 60 seconds, 180% for 30 seconds
Speed Reference Follower	Speed Potentiometer, 0-10 VDC (must be isolated) ¹
Power Supply for Auxiliary Relay	50 mA at 12 VDC
Digital Output	Circuit rated 50 mA and 30 VDC max (to drive auxiliary relay) ¹

¹ **WARNING:** Control terminals are not isolated from line voltage! Do not touch!

5.0 SM-Basic RATINGS

MODEL			INPUT (120/208/240 Vac, 50-60 Hz)			OUTPUT (0-200/230 Vac)	HEAT LOSS
MODEL NUMBER	FOR MOTORS RATED		INPUT PHASE	CURRENT (AMPS) (NOTE 1)	POWER (kVA)	CURRENT (AMPS) (NOTE 1)	WATTS (NOTE 3)
	HP	kW					
174374	0.25	0.20	1	6.0/3.5/3.0	0.72	1.4/1.6/1.4	21
174375	0.5	0.37	1	9.2/5.3/4.6	1.1	2.2/2.5/2.2	28
174376	1.0	0.75	1	15.8/9.1/7.9	1.9	4.0/4.6/4.0	46
174377	1.5	1.1	1	21.3/12.3/10.7	2.6	5.4/6.2/5.4	66

NOTE 1: The first current rating listed is for 120 Vac input, the second current rating is for 208 Vac input, and the third current rating is for 240 Vac input. 120 Vac input yields 230 Vac output.

MODEL			INPUT (208/240 Vac, 50-60 Hz)			OUTPUT (0-200/230 Vac)	HEAT LOSS
MODEL NUMBER	FOR MOTORS RATED		INPUT PHASE	CURRENT (AMPS) (NOTE 1)	POWER (kVA)	CURRENT (AMPS) (NOTE 1)	WATTS (NOTE 3)
	HP	kW					
174378	0.25	0.20	1	3.6/3.2	0.76	1.6/1.4	19
174379	0.5	0.37	1	5.4/4.7	1.2	2.4/2.2	26
174384			3	3.1/2.7	1.1		24
174380	1	0.75	1	9.7/8.4	2.1	4.6/4.0	47
174385			3	5.5/4.8	2.0		39
174381	1.5	1.1	1	12.4/10.8	2.6	6.2/5.4	74
174386			3	7.1/6.3	2.6		62
174382	2	1.5	1	14.8/12.9	3.1	7.8/6.8	86
174387			3	9.1/7.9	3.2		78
174383	3	2.2	1	19.7/17.1	4.1	11.0/9.6	130
174388			3	12.4/10.8	4.4		117

NOTE 1: Models are rated for use with single and three phase input.
NOTE 2: The higher current rating is for 208 Vac input and the lower current rating is for 240 Vac input.
NOTE 3: Values are worst-case (not typical) for 6 kHz carrier frequency at full speed and full load.

6.0 INSTALLATION

NOTE!

SM-Basic drives are intended for inclusion within other equipment, by professional electrical installers. They are not intended for stand-alone operation.

WARNING!

DRIVES MUST NOT BE INSTALLED WHERE SUBJECTED TO ADVERSE ENVIRONMENTAL CONDITIONS SUCH AS: COMBUSTIBLE, OILY, OR HAZARDOUS VAPORS OR DUST; EXCESSIVE MOISTURE OR DIRT; VIBRATION; EXCESSIVE AMBIENT TEMPERATURES. CONSULT AC TECHNOLOGY FOR MORE INFORMATION ON THE SUITABILITY OF A DRIVE TO A PARTICULAR ENVIRONMENT.

WARNING!

Hazard of electrical shock! The SM-Basic control terminals are not isolated from line voltage! Line voltage is present between the control terminals and ground. Do not touch!

Disconnect input power and wait three minutes before making connections to the control terminals.

Devices (such as switches, pushbuttons, potentiometers, relays, etc) and wiring connected to the control terminals are hot to ground and must have an insulation rating of at least 240 Vac or a dielectric rating of at least 1500 volts to prevent damage to equipment and/or injury to personnel.

SM-Basic models are suitable for UL pollution degree 2 environment only, and MUST be installed in an electrical enclosure which will provide complete mechanical protection and will maintain the internal temperature within the drive's ambient operating temperature rating. All drive models MUST be mounted in a vertical position for proper heatsink cooling.

Maintain a minimum spacing around the drive of at least one inch on each side and two inches on the top and bottom. Allow more spacing if the drive is mounted next to other heat-producing equipment. Do not mount drives above other drives or heat producing equipment. Fans or blowers should be used to insure proper cooling in tight quarters.

In order to properly size an enclosure, the heat generated by the drive(s) must be known. Refer to the HEAT LOSS column in Section 5.0 - SM-Basic RATINGS. An enclosure manufacturer can then determine the required enclosure size based on the total heat generated inside the enclosure (from the drive(s) and other heat sources), the maximum allowable temperature inside the enclosure, the maximum ambient temperature outside the enclosure, and the enclosure properties.

The SM-Basic Series is UL approved for solid state motor overload protection. Therefore, a separate thermal overload relay is not required for single motor applications.

6.1 INSTALLATION AFTER A LONG PERIOD OF STORAGE

WARNING!

Severe damage to the drive can result if it is operated after a long period of storage or inactivity without reforming the DC bus capacitors!

If input power has not been applied to the drive for a period of time exceeding three years (due to storage, etc), the electrolytic DC bus capacitors within the drive can change internally, resulting in excessive leakage current. This can result in premature failure of the capacitors if the drive is operated after such a long period of inactivity or storage.

In order to reform the capacitors and prepare the drive for operation after a long period of inactivity, apply input power to the drive for 8 hours prior to actually operating the motor.

6.2 EXPLOSION PROOF APPLICATIONS

Explosion proof motors that are not rated for inverter use lose their certification when used for variable speed. Due to the many areas of liability that may be encountered when dealing with these applications, the following statement of policy applies:

“Leeson Electric Corporation inverter products are sold with no warranty of fitness for a particular purpose or warranty of suitability for use with explosion proof motors. Leeson Electric Corporation accepts no responsibility for any direct, incidental or consequential loss, cost, or damage that may arise through the use of its AC inverter products in these applications. The purchaser expressly agrees to assume all risk of any loss, cost, or damage that may arise from such application. Leeson Electric Corporation or Leeson Electric Corporation’s engineering department will not knowingly approve applications involving explosion proof motors.”

7.0 INPUT AC POWER REQUIREMENTS

WARNING!

Hazard of electrical shock! Capacitors retain charge after power is removed. Disconnect incoming power and wait until the voltage between terminals B+ and B- is 0 VDC before servicing the drive.

The input voltage must match the nameplate voltage rating of the drive. Voltage fluctuation must not vary by greater than 10% overvoltage or 15% undervoltage.

NOTE: Drives with dual input voltage ratings must be programmed for the proper supply voltage (refer to Parameter 01 - LINE VOLTAGE SELECTION in Section 15.0 - DESCRIPTION OF PARAMETERS).

The drive is suitable for use on a circuit capable of delivering not more than 5,000 RMS symmetrical amperes at the drive's rated voltage.

Three phase voltage imbalance must be less than 2.0% phase to phase. Excessive phase to phase imbalance can cause severe damage to the drive.

Motor voltage should match line voltage in normal applications. The drive's maximum output voltage will equal the input voltage. Use extreme caution when using a motor with a voltage rating which is different from the input line voltage.

7.1 INPUT VOLTAGE RATINGS

SM-Basic Series drives are rated for 120/208/240 Vac, single phase, 50-60 Hz input. The drive will function with input voltage of 120 Vac (+10%, -15%), at 48 to 60 Hz, or with input voltage of 208 to 240 Vac (+ 10%, - 15%), at 48 to 62 Hz.

SM-Basic Series drives are rated for 208/240 Vac, single phase, 50-60 Hz input. The drive will function with input voltages of 208 to 240 Vac (+10%, -15%), at 48 to 62 Hz.

SM-Basic Series drives are rated for 208/240 Vac, three phase, 50-60 Hz input. The drive will function with input voltages of 208 to 240 Vac (+ 10%, - 15%), at 48 to 62 Hz.

NOTE: Parameter 01 - LINE VOLTAGE SELECTION must be programmed according to the applied input voltage. See Section 15.0 - DESCRIPTION OF PARAMETERS.

7.2 INPUT FUSING AND DISCONNECT REQUIREMENTS

A circuit breaker or a disconnect switch with fuses must be provided in accordance with the National Electric Code (NEC) and all local codes.

The SM-Basic drive is capable of withstanding up to 150% current overload for 60 seconds. Select a fuse or magnetic trip circuit breaker rated at 1.5 times the input current rating of the drive (the minimum fuse size should be 10 amps, regardless of input current rating). Refer to Section 5.0 - SM-Basic RATINGS.

Minimum voltage rating of the protection device should be 250 Vac for 120/208/240 Vac and 208/240 Vac rated drives.

UL Class CC fast-acting, current limiting type fuses should be used when input fusing is required. Select fuses with low I^2T values, rated at 200,000 AIC. Recommended fuses are Bussman KTK-R. Similar fuses with equivalent ratings by other manufacturers may also be acceptable.

8.0 POWER WIRING

WARNING!

Hazard of electrical shock! Capacitors retain charge after power is removed. Disconnect incoming power and wait until the voltage between terminals B+ and B- is 0 VDC before servicing the drive.

Note drive input and output current ratings and check applicable electrical codes for required wire type and size, grounding requirements, over-current protection, and incoming power disconnect, before wiring the drive. Size conservatively to minimize voltage drop.

Strip off 0.20 to 0.25 inches of insulation for input power, output power, and DC Bus wiring. The input power, output power, and DC Bus terminals must be tightened to a torque of 4.0 to 4.5 lb-in.

Input fusing and a power disconnect switch or contactor **MUST** be wired in series with terminals L1, L2, and L3 for three phase input models. For 208/240 Vac single phase input models, use terminals L1 and L2. For 120 Vac single phase input models, use terminals L1 and N. This disconnect must be used to power down the drive when servicing, or when the drive is not to be operated for a long period of time, but should not be used to start and stop the motor. Repetitive cycling of a disconnect or input contactor (more than once every two minutes) may cause damage to the drive.

8.1 WIRING FOR SINGLE PHASE OR THREE PHASE INPUT

If the drive is rated for 120/208/240 Vac single phase input, wire the input to terminals L1 and N for 120 Vac voltage, or wire to terminals L1 and L2 (do not wire to N) for 208/240 Vac input voltage. Refer to Section 9.0 - SM-Basic POWER WIRING DIAGRAM.

If the drive is rated for 208/240 Vac single phase input, wire the input to terminals L1 and L2.

If the drive is rated for three phase input, wire the input to terminals L1, L2, and L3.

All three power output wires, from terminals T1, T2, and T3 to the motor, must be kept tightly bundled and run in a separate conduit away from all other power and control wiring.

Do not install contactors or disconnects between the drive and motor without consulting Leeson Electric Corporation for more information.

9.0 SM-Basic POWER WIRING DIAGRAM

THREE PHASE INPUT
(where applicable)

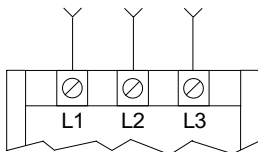

120 Vac SINGLE PHASE INPUT
(where applicable)

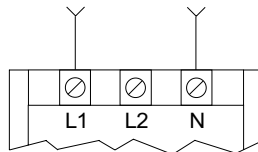

208/240 Vac SINGLE PHASE INPUT
(where applicable)

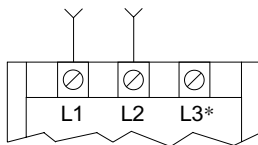

OUTPUT (ALL)

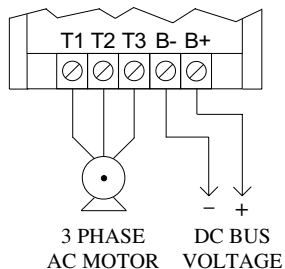

WARNING!

Do not connect incoming AC power to output terminals T1, T2, or T3. Severe damage to the drive will result.

NOTES:

1. WIRE AND GROUND IN ACCORDANCE WITH NEC OR CEC, AND ALL APPLICABLE LOCAL CODES.
2. Motor wires MUST be run in a separate steel conduit away from control wiring and incoming AC power wiring.
3. Do not install contactors between the drive and the motor without consulting Leeson Electric Corporation for more information. Failure to do so may result in drive damage.
4. Use only UL and CSA listed and approved wire.
5. Minimum wire voltage ratings: 300 V for 120, 208 and 240 Vac systems.
6. Wire gauge must be based on a minimum of 125% of the rated input/output current of the drive, and a minimum 75°C insulation rating. Use copper wire only.
7. Strip off 0.20 to 0.25 inches of insulation for input power, output power, and DC Bus wiring.

10.0 CONTROL WIRING

WARNING!

Hazard of electrical shock! The SM-Basic control terminals are not isolated from line voltage! Line voltage is present between the control terminals and ground. Do not touch!

Disconnect input power and wait three minutes before making connections to the control terminals.

Devices (such as switches, pushbuttons, potentiometers, relays, etc) and wiring connected to the control terminals are hot to ground and must have an insulation rating of at least 240 Vac or a dielectric rating of at least 1500 volts to prevent damage to equipment and/or injury to personnel.

10.1 CONTROL WIRING VS. POWER WIRING

External control wiring **MUST** be run in a separate conduit away from all other input and output power wiring. If control wiring is not kept separate from power wiring, electrical noise may be generated on the control wiring that will cause erratic drive behavior. Use twisted wires or shielded cable rated for 300 VDC minimum (**do not ground the shield**).

10.2 SURGE SUPPRESSION ON RELAYS

Current and voltage surges and spikes in the coils of contactors, relays, and solenoids, near or connected to the drive, can cause erratic drive operation. Snubbers should be used on any coils associated with the drive. For AC loads, snubbers should consist of a resistor and a capacitor in series across the coil. For DC loads, a free-wheeling or flyback diode should be placed across the coil.

10.3 START/STOP CONTROL

There are various control schemes that allow for 2-wire and 3-wire Start/Stop circuits. Refer to the wiring diagrams in Section 11.0 - SM-Basic CONTROL WIRING DIAGRAMS.

10.4 SPEED REFERENCE SIGNALS

SPEED POT Connect the wiper to terminal TB-5, and connect the high and low end leads to terminals TB-6 and TB-3, respectively. The speed pot can be 5k Ω up to 10k Ω .

0-10 VDC Wire the positive to terminal TB-5 and the negative to terminal TB-3. **The 0-10 VDC signal must be isolated**, as the control terminals are at line voltage potential.

DO NOT connect the low side of the speed pot or 0-10 VDC signal to ground.

10.5 SPEED REFERENCE SELECTION

If a speed pot is to be used to control the drive speed, terminal TB-13A, 13B, or 13C (Parameter 10, 11, or 12) may be programmed as the input select for the speed pot. When that TB-13 terminal is then closed to TB-11, the drive will follow the speed pot input.

If the speed pot is not selected on the terminal strip using TB-13A, 13B, or 13C, speed control will default to STANDARD mode, which is governed by the setting of Parameter 05 - STANDARD SPEED SOURCE. The STANDARD SPEED SOURCE can be the ▲ and ▼ buttons on the front of the drive, PRESET SPEED #1 (Parameter 31), or a speed pot.

PRESET SPEEDS

TB-13A can be programmed to select PRESET SPEED #1, TB-13B to select PRESET SPEED #2, and TB-13C to select PRESET SPEED #3. There are a total of seven preset speeds, which are activated by different combinations of contact closures between TB-13A, 13B, 13C and TB-11. Refer to Parameters 31-37 in Section 15.0 - DESCRIPTION OF PARAMETERS.

JOG

TB-13B can be programmed to select either JOG FORWARD or JOG REVERSE. The Jog speed is set by PRESET SPEED #2. Close TB-13B to TB-11 to JOG, and open the contact to STOP.

WARNING!

When operating in JOG mode, the STOP signal and the AUXILIARY STOP function (see Parameters 10-12) **WILL NOT** stop the drive. To stop the drive, remove the JOG command.

JOG REVERSE will operate the drive in reverse rotation even if ROTATION DIRECTION (Parameter 17) is set to FORWARD ONLY.

NOTE: If the drive is commanded to JOG while running, the drive will enter JOG mode and run at PRESET SPEED #2. When the JOG command is removed, the drive will STOP.

MOTOR OPERATED POT (MOP) / FLOATING POINT CONTROL

TB-13B and TB-13C are required for this function, which controls the drive speed using normally open contacts wired to the terminal strip. Program TB-13B for DECREASE FREQ, and program TB-13C for INCREASE FREQ. Closing the contacts between the TB-13 terminals and TB-11 will cause the speed setpoint to increase or decrease until the contact is opened. The INCREASE FREQ function will only operate while the drive is running.

NOTE: If TB-13A, TB-13B, and TB-13C are all programmed to select speed references, and two or three of the terminals are closed to TB-11, the higher terminal has priority and will override the others. For example, if TB-13A is programmed to select a speed pot, and TB-13C is programmed to select PRESET SPEED #3, closing both terminals to TB-11 will cause the drive to respond to PRESET SPEED #3, because TB-13C overrides TB-13A.

10.7 DRIVE STATUS DIGITAL OUTPUTS

There is one open-collector output at terminal TB-14. The open-collector circuit is a current-sinking type rated at 30 VDC and 50 mA maximum.

The open-collector output can be programmed to indicate any one of the following: RUN, FAULT, INVERSE FAULT, FAULT LOCKOUT, AT SPEED, ABOVE PRESET SPEED #3, CURRENT LIMIT, AUTO SPEED MODE, and REVERSE. Refer to Parameter 06 in Section 15.0 - DESCRIPTION OF PARAMETERS.

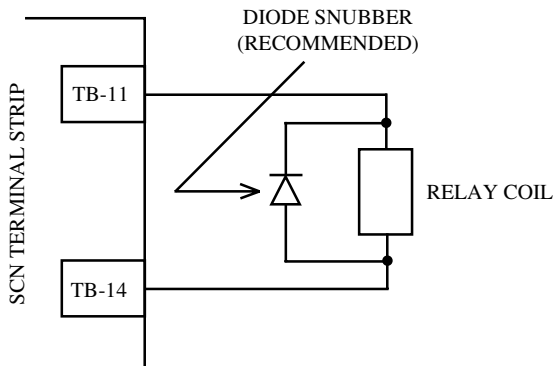

WARNING!

Hazard of electrical shock! The SCN control terminals are not isolated from line voltage! Line voltage is present between the control terminals and ground. Do not touch!

Only use relays with an insulation rating of at least 240 Vac or a dielectric rating of at least 1500 volts to prevent damage to equipment and/or injury to personnel.

NOTE: When the optional remote keypad is used, TB-14 is wired to the remote keypad and cannot be used for status indication.

11.0 SM-Basic CONTROL WIRING DIAGRAMS

11.1 TWO-WIRE START/STOP CONTROL

WARNING!

Hazard of electrical shock! The SM-Basic control terminals are not isolated from line voltage! Line voltage is present between the control terminals and ground. Do not touch!

Disconnect input power and wait three minutes before making connections to the control terminals.

Devices (such as switches, pushbuttons, potentiometers, relays, etc) and wiring connected to the control terminals are hot to ground and must have an insulation rating of at least 240 Vac or a dielectric rating of at least 1500 volts to prevent damage to equipment and/or injury to personnel.

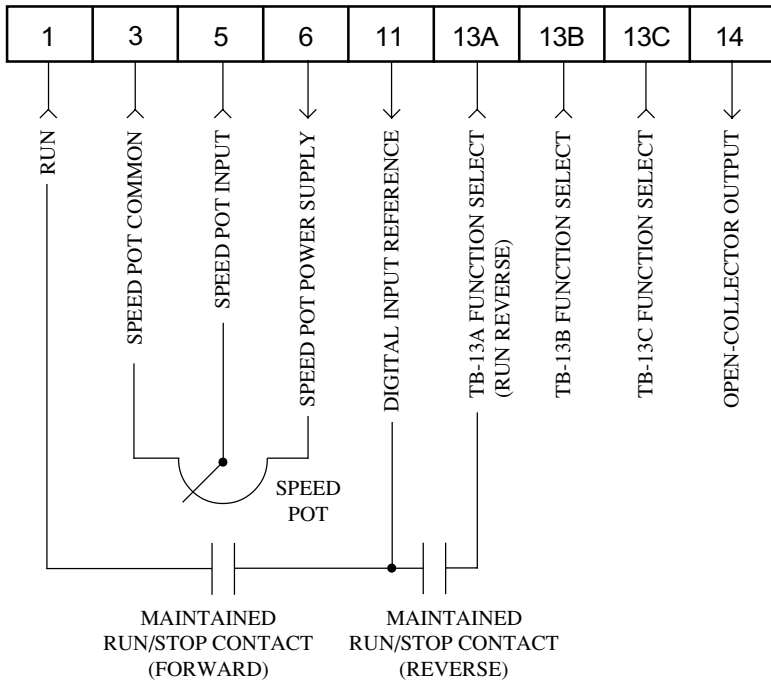

NOTES:

1. Close TB-1 to TB-11 to RUN, and open to STOP. TB-1 functions as a RUN input for two-wire start/stop circuits, and a STOP input for three-wire start/stop circuits. Refer to Section 11.2.
2. If reverse direction is required, set ROTATION (Parameter 17) to FORWARD AND REVERSE (02), and program TB-13A (Parameter 10) to RUN REVERSE (05). Close TB-13A to TB-11 to RUN in the reverse direction, and open to STOP.
3. For speed pot control, set STANDARD SPEED SOURCE (Parameter 05) to SPEED POT (03).

WARNING!

Hazard of electrical shock! The SM-Basic control terminals are not isolated from line voltage! Line voltage is present between the control terminals and ground. Do not touch!

Disconnect input power and wait three minutes before making connections to the control terminals.

Devices (such as switches, pushbuttons, potentiometers, relays, etc) and wiring connected to the control terminals are hot to ground and must have an insulation rating of at least 240 Vac or a dielectric rating of at least 1500 volts to prevent damage to equipment and/or injury to personnel.

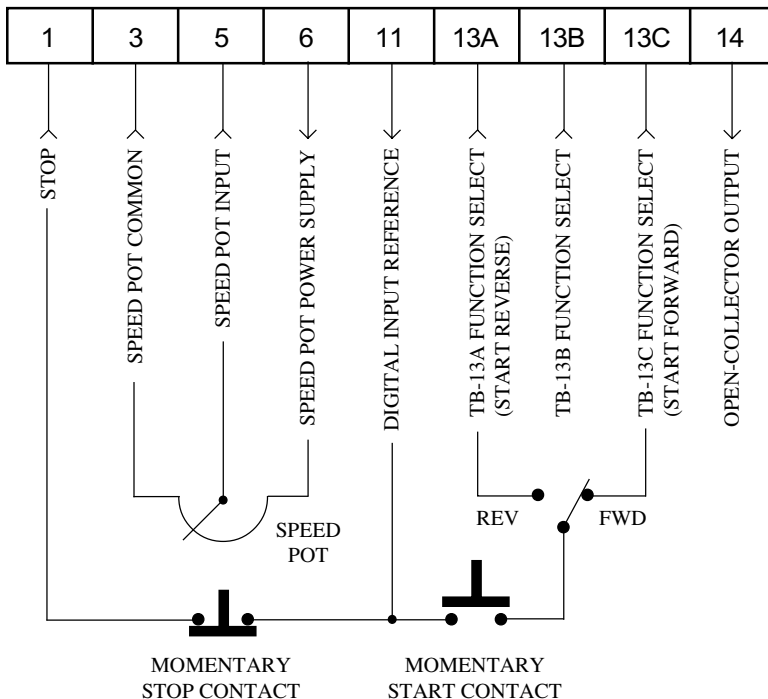

NOTES:

1. Program TB-13C (Parameter 12) for START FORWARD (05).
2. If reverse direction is required, set ROTATION (Parameter 17) to FORWARD AND REVERSE (02), and program TB-13A (Parameter 10) for START REVERSE (06).
3. Momentarily close TB-13C to TB-11 to START in the forward direction, or close TB-13A to TB-11 to START in the reverse direction. Momentarily open TB-1 to TB-11 to STOP the drive.
4. For speed pot control, set STANDARD SPEED SOURCE (Parameter 05) to SPEED POT (03).

WARNING!

Hazard of electrical shock! The SM-Basic control terminals are not isolated from line voltage! Line voltage is present between the control terminals and ground. Do not touch!

Disconnect input power and wait three minutes before making connections to the control terminals.

Devices (such as switches, pushbuttons, potentiometers, relays, etc) and wiring connected to the control terminals are hot to ground and must have an insulation rating of at least 240 Vac or a dielectric rating of at least 1500 volts to prevent damage to equipment and/or injury to personnel.

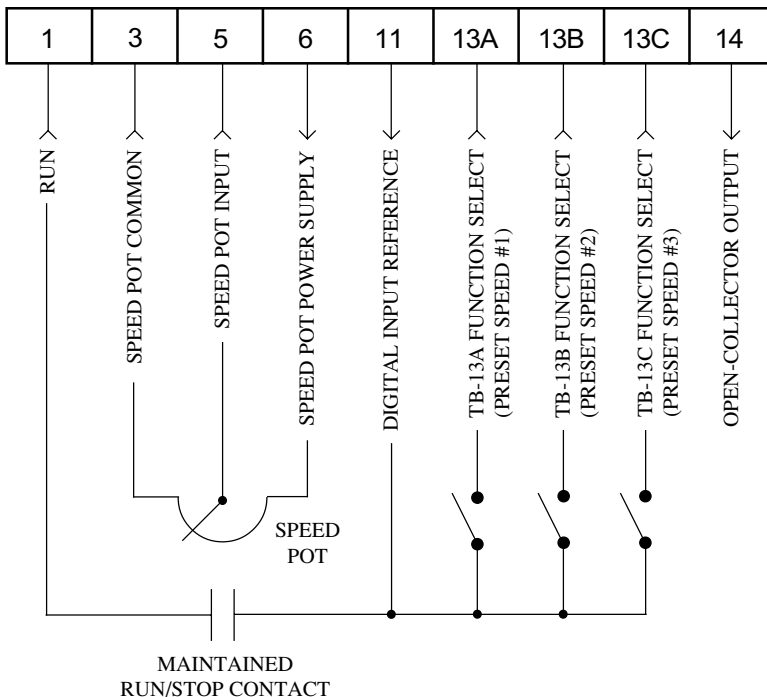

NOTES:

1. For preset speed control, all or some of the TB-13 terminals must be programmed as preset speed selects. If only two or three preset speeds are required, only two of the TB-13 terminals must be used. Refer to the table in the description of Parameters 31-37 in Section 15.0.
2. Program the PRESET SPEEDS (Parameters 31-37) to the desired values.
3. If speed pot control is desired when none of the preset speeds are selected (all preset speed selects are open to TB-11), set STANDARD SPEED SOURCE (Parameter 05) to SPEED POT (03).

12.0 INITIAL POWER UP AND MOTOR ROTATION

WARNING!

DO NOT connect incoming AC power to output terminals T1, T2, and T3! Severe damage to the drive will result. Do not continuously cycle input power to the drive more than once every two minutes. Damage to the drive will result.

WARNING!

Hazard of electrical shock! The SM-Basic control terminals are not isolated from line voltage! Line voltage is present between the control terminals and ground. Do not touch!

Capacitors retain charge after power is removed. Disconnect input power and wait until the voltage between terminals B+ and B- is 0 VDC before making control connections or servicing the drive.

WARNING!

Severe damage to the drive can result if it is operated after a long period of storage or inactivity without reforming the DC bus capacitors!

If input power has not been applied to the drive for a period of time exceeding three years (due to storage, etc), the electrolytic DC bus capacitors within the drive can change internally, resulting in excessive leakage current. This can result in premature failure of the capacitors if the drive is operated after such a long period of inactivity or storage.

In order to reform the capacitors and prepare the drive for operation after a long period of inactivity, apply input power to the drive for 8 hours prior to actually operating the motor.

Before attempting to operate the drive, motor, and driven equipment, be sure all procedures pertaining to installation and wiring have been properly followed.

If possible, disconnect the driven load from the motor. Verify that the drive input terminals (L1, L2, and L3 or N) are wired to the proper input voltage per the nameplate rating of the drive.

Energize the incoming power line. The LED display will flash a two-digit number (15 in the example below) that identifies the parameter version contained in the drive ("15" actually means parameter version 315). The display should then read "--", which indicates that the drive is in a STOP condition. This is shown below:

Apply input power

Display flashes parameter version (00-99)

Display then reads "--"

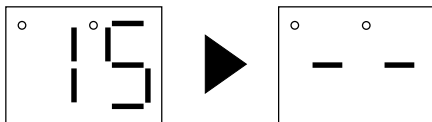

Follow the procedure below to check the motor rotation. This procedure assumes that the drive has been powered up for the first time, and that none of the parameters have been changed.

1. Use the ▼ button to decrease the speed setpoint to 0 Hz. The left decimal point will illuminate as the speed setpoint is decreased.

Once 0 Hz is reached, the display will toggle between “00” and “- -”, which indicates that the drive is in a STOP condition with a speed setpoint of 0 Hz.

2. Give the drive a START command. This can be done using one of several wiring methods described in Section 11.0 - SM-Basic CONTROL WIRING DIAGRAMS. Once the START command is issued, the display will read “00”, indicating that the drive is in a RUN condition with a speed setpoint of 0 Hz.
3. Use the ▲ button to increase the speed setpoint until the motor starts to rotate. The left decimal point will light as the speed setpoint is increased.
4. If the motor is rotating in the wrong direction, give the drive a STOP command and remove power from the drive. Wait three minutes for the bus capacitors to discharge, and swap any two of the motor wires connected to T1, T2, and T3.

NOTE: The drive is phase insensitive with respect to incoming line voltage. This means that the drive will operate with any phase sequence of the incoming three phase voltage. Therefore, to change the motor rotation, the phases must be swapped at the drive output terminals or at the motor.

13.0 PROGRAMMING THE SM-Basic DRIVE

The drive may be programmed by one of two methods: using the three buttons and 2-digit LED display on the front of the drive, or programming the Electronic Programming Module (EPM) using the optional EPM Programmer. This section describes programming the drive using the buttons and display, which are shown below:

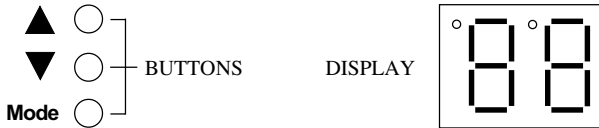

To enter the PROGRAM mode to access the parameters, press the **Mode** button. This will activate the PASSWORD prompt (if the password has not been disabled). The display will read "00" and the upper right-hand decimal point will be blinking, as shown below:

Press **Mode**

Display reads "00"

Right decimal point blinks

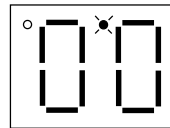

Use the ▲ and ▼ buttons to scroll to the password value (the factory default password is "25") and press the **Mode** button. Once the correct password value is entered, the display will read "01", which indicates that the PROGRAM mode has been accessed at the beginning of the parameter menu (01 is the first parameter), and the upper right decimal point will turn on solid. This is shown below:

Use ▲ and ▼ to scroll to the password value

Press **Mode** to enter password

Parameter menu is accessed at the first parameter

Upper right decimal point turns on solid.

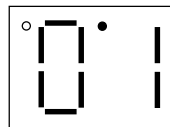
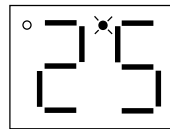

NOTE: If the display flashes “Er”, the password was incorrect, and the process to enter the password must be repeated.

Use the ▲ and ▼ buttons to scroll to the desired parameter number. In the example below, Parameter 19 is being displayed, which is the ACCELERATION TIME of the drive:

Use ▲ and ▼ to scroll to the desired parameter number

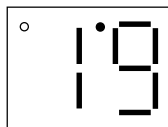

Once the desired parameter number is found, press the **Mode** button to display the present parameter setting. The upper right-hand decimal point will begin blinking, indicating that the present parameter setting is being displayed, and that it can be changed by using the ▲ and ▼ buttons.

Press **Mode** to display present parameter setting (present example setting is 15)

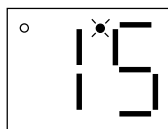

Right decimal point blinks

Use ▲ and ▼ to change setting (example setting changed to 30)

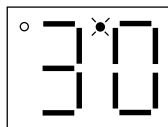

Press **Mode** to store new setting

Pressing the **Mode** will store the new setting and also exit the PROGRAM mode. To change another parameter, press the **Mode** key again to re-enter the PROGRAM mode (the parameter menu will be accessed at the parameter that was last viewed or changed before exiting). If the **Mode** key is pressed within two minutes of exiting the PROGRAM mode, the password is not required access the parameters. After two minutes, the password must be entered in order to access the parameters again.

13.2 ELECTRONIC PROGRAMMING MODULE (EPM)

Every SM-Basic Series drive has an Electronic Programming Module (EPM) installed on the main control board. The EPM stores the user's parameter settings and special OEM default settings (if programmed). The EPM is removable, allowing it to be installed in another drive for quick set-up. For example, if a drive is being replaced with a new one, the EPM can be taken out of the first drive and installed in the new drive. Downtime is minimized because the new drive does not require programming - it is ready to run when the EPM is installed.

The SM-Basic Series drive contains two or three sets of parameter values, depending on whether the drive has been programmed with optional OEM default settings. The first set of values is the factory default settings, which are permanently stored on the main control board and cannot be changed. The second set of values is the user settings, which are stored in the EPM. When the drive leaves the factory, the user settings are the same as the factory default settings, but the user settings can be changed to configure the drive for a particular application. The optional third set of values is the OEM default settings, which are also stored in the EPM. OEM default settings are typically used in cases where many drives are used for the same application, which requires that all of the drives have the same parameter settings. The OEM default settings cannot be changed without the optional EPM Programmer. The drive can be programmed to operate according to the user settings or the OEM default settings (see Parameter 48 in Section 15.0).

NOTE: The drive will not operate without the EPM installed. The drive will display "F1" if the EPM is missing or damaged.

WARNING!

Do not remove the EPM while power is applied to the drive. Damage to the EPM and/or drive may result.

An EPM Programmer is available as an option from SM-Basic, which has the ability to quickly and easily program many SM-Basic drives for the same configuration. Once a "master" EPM is programmed with the desired parameter settings, the EPM Programmer can copy those settings to other EPMs, allowing many drives to be configured very quickly. Please consult the EPM Programmer Instruction Manual or contact the factory for more information.

If the OEM settings in the EPM become corrupted, the drive will operate normally, until an attempt is made to perform a RESET OEM using Parameter 48 - PROGRAM SELECTION. The drive will then flash "GF" to indicate that the OEM settings are no longer valid. This will require that the EPM be re-programmed using the optional EPM Programmer.

If the OEM settings and the user settings are both corrupted, the drive will display "GF" immediately and the drive will require a RESET 60 or RESET 50 using Parameter 48 - PROGRAM SELECTION. Once the RESET is performed, the parameters can then be programmed individually to match the OEM default settings. This will allow the drive to operate as if it were in OEM mode, even though it is actually operating in USER mode. Refer to Parameter 48 in Section 15.0 - DESCRIPTION OF PARAMETERS.

NOTE: The drive will also display "GF" if a RESET OEM or OPERATE WITH OEM SETTINGS is attempted when the drive is not equipped with the OEM default option.

14.0 PARAMETER MENU

NO.	PARAMETER NAME	RANGE OF ADJUSTMENT	FACTORY DEFAULT (NOTE 1)
01	LINE VOLTAGE	HIGH (01), LOW (02)	HIGH (01)
02	CARRIER FREQUENCY	4kHz (01), 6 kHz (02), 8 kHz (03), 10 kHz (04)	6 kHz (02)
03	START METHOD	NORMAL (01), START ON POWER UP (02), START WITH DC BRAKE (03), AUTO RESTART WITH DC BRAKE (04), FLYING RESTART 1 (05), FLYING RESTART 2 (06), FLYING RESTART 3 (07)	NORMAL (01)
04	STOP METHOD	COAST (01), COAST WITH DC BRAKE (02), RAMP (03), RAMP WITH DC BRAKE (04)	COAST (01)
05	STANDARD SPEED SOURCE	KEYPAD (01), PRESET #1 (02), SPEED POT (03)	KEYPAD (01)
06	TB-14 OUTPUT	NONE (01), RUN (02), FAULT (03), INVERSE FAULT (04), FAULT LOCKOUT (05), AT SET SPEED (06), ABOVE PRESET #3 (07), CURRENT LIMIT (08), AUTO SPEED (09), REVERSE (10), DB BRAKE (11)	NONE (01)
10	TB-13A FUNCTION SELECT	NONE (01), SPEED POT (02), PRESET SPEED #1 (03), START FORWARD (04), RUN REVERSE (05), START REVERSE (06), EXTERNAL FAULT (07), DB FAULT (08), AUXILIARY STOP (09), ACCEL/DECEL #2 (10)	NONE (01)
11	TB-13B FUNCTION SELECT	NONE (01), SPEED POT (02), PRESET SPEED #2 (03), DECREASE FREQ (04), JOG FORWARD (05), JOG REVERSE (06), EXTERNAL FAULT (07), DB FAULT (08), AUXILIARY STOP (09), ACCEL/DECEL #2 (10)	NONE (01)
12	TB-13C FUNCTION SELECT	NONE (01), SPEED POT (02), PRESET SPEED #3 (03), INCREASE FREQ (04), START FORWARD (05), EXTERNAL FAULT (06), DB FAULT (07), AUXILIARY STOP (08), ACCEL/DECEL #2 (09)	NONE (01)

NOTE 1: Factory defaults are shown for a 60 Hz base frequency. See Parameter 48 for 50 Hz base frequency.

NO.	PARAMETER NAME	RANGE OF ADJUSTMENT	FACTORY DEFAULT (NOTE 1)
14	CONTROL	TERMINAL STRIP ONLY (01), REMOTE KEYPAD ONLY (02)	TERMINAL STRIP ONLY (01)
17	ROTATION	FORWARD ONLY (01), FORWARD AND REVERSE (02)	FORWARD ONLY (01)
18	TIME RANGE SELECT	x0.1 (01), x1.0 (02), x10.0 (03)	x1.0 (02)
19	ACCELERATION TIME	0.1 - 990 SEC	20 SEC
20	DECELERATION TIME	0.1 - 990 SEC	20 SEC
21	DC BRAKE TIME	0.0 - 990 SEC	0 SEC
22	DC BRAKE VOLTAGE	0 - 30 %	0 %
23	MINIMUM FREQUENCY	0 - MAXIMUM FREQUENCY	0 Hz
24	MAXIMUM FREQUENCY	MINIMUM FREQUENCY - 99 Hz	60 Hz
25	CURRENT LIMIT	30 - 180 % (NOTE 2)	180 %
26	MOTOR OVERLOAD	30 - 100 %	100 %
27	BASE FREQUENCY	25 - 99 Hz	60 Hz
28	FIXED BOOST	0 - 30 %	1 %
29	ACCEL BOOST	0 - 20 %	0 %
30	SLIP COMPENSATION	0.0 - 5.0 %	0 %
31-37	PRESET SPEEDS	0 - MAXIMUM FREQUENCY	0 Hz
38	SKIP BANDWIDTH	0 - 10 Hz	0 Hz
42	ACCEL / DECEL #2	0.1 - 990 SEC	20 SEC
44	PASSWORD	00 - 99	25
47	CLEAR HISTORY	MAINTAIN (01), CLEAR (02)	MAINTAIN (01)
48	PROGRAM SELECTION	USER SETTINGS (01), OEM SETTINGS (02), RESET OEM (03), RESET 60 (04), RESET 50 (05), TRANSLATE (06)	USER SETTINGS (01)
50	FAULT HISTORY	(VIEW-ONLY)	(N/A)
51	SOFTWARE CODE	(VIEW-ONLY)	(N/A)
52	DC BUS VOLTAGE	(VIEW-ONLY)	(N/A)
53	MOTOR VOLTAGE	(VIEW-ONLY)	(N/A)
54	LOAD	(VIEW-ONLY)	(N/A)
55	SPEED POT INPUT	(VIEW-ONLY)	(N/A)
57	TB STRIP STATUS	(VIEW-ONLY)	(N/A)
58	KEYPAD STATUS	(VIEW-ONLY)	(N/A)

NOTE 1: Factory defaults are shown for a 60 Hz base frequency. See Parameter 48 for 50 Hz base frequency.

NOTE 2: If LINE VOLTAGE is set to LOW, maximum setting is 150%.

15.0 DESCRIPTION OF PARAMETERS

01 LINE VOLTAGE SELECTION

This calibrates the drive for the actual applied input voltage, and can be set to HIGH (01) or LOW (02). Refer to the table below for the proper setting depending on the input voltage.

MODEL	RATED INPUT VOLTAGE	INPUT PHASE	APPLIED INPUT VOLTAGE	PARAMETER SETTING
SN100S	120 / 208 / 240 Vac	1	110 - 120 Vac or 220 - 240 Vac	HIGH (01)
		1	200 - 208 Vac	LOW (02)
N 0S	208 / 240 Vac	1 or 3	220 - 240 Vac	HIGH (01)
		1 or 3	200 - 208 Vac	LOW (02)
SN200	208 / 240 Vac	3	0 - 240 Vac	HIGH (01)
		3	200 - 208 Vac	LOW (02)

NOTE: If this parameter is changed while the drive is running, the new value will not take effect until the drive is stopped.

02 CARRIER FREQUENCY

This sets the switching rate of the output IGBT's. Increasing the carrier frequency will result in less audible motor noise. Available settings are: 4 kHz, 6 kHz, 8 kHz, and 10 kHz.

PARAMETER SETTING	CARRIER FREQUENCY	MAXIMUM OUTPUT FREQUENCY	AMBIENT OR OUTPUT DERATE (NOTE 2)
01	4 kHz	99 Hz	50 C or 100%
02	6 kHz	99 Hz	50 C or 100%
03	8 kHz	99 Hz	43 C or 92%
04	10 kHz	99 Hz	35 C or 82%

NOTE 1: The SM-Basic drive is fully rated up to 6 kHz carrier frequency. If the 8 kHz or 10 kHz carrier frequency is selected, the drive's ambient temperature rating OR output current rating must be de-rated to the value shown in the table above.

NOTE 2: If this parameter is changed while the drive is running, the change will not take effect until the drive is stopped.

03 START METHOD

WARNING!

Automatic starting of equipment may cause damage to equipment and/or injury to personnel!
Automatic start should only be used on equipment that is inaccessible to personnel.

- 01 NORMAL: The drive will start when the appropriate contact is closed on the terminal strip. See Section 11 for possible control configurations.
- 02 START ON POWER UP: The drive will automatically start upon application of input power.
- 03 START WITH DC BRAKE: When a START command is given, the drive will apply DC BRAKE VOLTAGE (Parameter 22) for the duration of DC BRAKE TIME (Parameter 21) prior to starting the motor to ensure that the motor is not turning.
- 04 AUTO RESTART WITH DC BRAKING: Upon a START command, after a fault, or upon application of power, the drive will apply DC BRAKE VOLTAGE (Parameter 22) for the duration of DC BRAKE TIME (Parameter 21) prior to starting (or restarting) the motor.
- 05 FLYING RESTART 1: LOW performance. Slowest synchronization and lowest current level. This setting results in the smoothest synchronization.
- 06 FLYING RESTART 2: MEDIUM performance. Faster synchronization and higher current level. This setting allows faster synchronization while retaining smoothness.
- 07 FLYING RESTART 3: HIGH performance. Fastest synchronization and highest current level. This setting allows the fastest synchronization, but sacrifices smoothness.

When programmed for auto-restart (settings 04 - 07), the drive will attempt three restarts after a fault. The interval between restart attempts is 15 seconds for setting 04, and 2 seconds for settings 05, 06 and 07. During the interval between restart attempts, the display will read "SP" to indicate Start Pending. If all three restart attempts fail, the drive will trip into FAULT LOCKOUT (displayed "LC") and require a manual reset. Refer to Section 16.0 - TROUBLESHOOTING.

The FLYING RESTART 1 - 3 settings allow the drive to start into a spinning load after a fault or upon application of input power. They differ in the time required to find the motor and the amount of current required to synchronize with it. The faster the drive attempts to find the motor, the more current is required. The first two restart attempts will try to start into the spinning load, but the third restart attempt will act like AUTO RESTART WITH DC BRAKING.

NOTE: Settings 02 and 04 - 07 require a two-wire start/stop circuit to operate. The RUN contact must remain closed for the power-up start and auto-restart functions to operate.

04 STOP METHOD

- 01 **COAST TO STOP:** When a STOP command is given, the drive shuts off the output to the motor, allowing it to coast freely to a stop.
- 02 **COAST WITH DC BRAKE:** When a stop command is given, the drive will activate DC braking (after a delay of up to 2 seconds, depending on frequency) to help decelerate the load. Refer to Parameters: 21 - DC BRAKE TIME, and 22 - DC BRAKE VOLTAGE.
- 03 **RAMP TO STOP:** When a stop command is given, the drive will decelerate the motor to a stop at the rate determined by Parameter 20 - DECELERATION TIME.
- 04 **RAMP WITH DC BRAKE:** When a stop command is given, the drive will decelerate the motor down to 0.2 Hz (at the rate set by Parameter 20 - DECELERATION TIME) and then activate DC braking according to the settings of Parameters 21 - DC BRAKE TIME and 22 - DC BRAKE VOLTAGE. This is used to bring the load to a final stop, as the motor may still be turning slightly after the drive stops.

05 STANDARD SPEED SOURCE

This selects the speed reference source when the drive is in STANDARD speed mode. The following speed references can be selected:

- 01 **KEYPAD:** Use the ▲ and ▼ buttons to scroll to the desired speed.
- 02 **PRESET SPEED #1:** The drive will operate at the frequency set into Parameter 31.
- 03 **SPEED POT:** The drive will respond to a speed pot. Refer to Section 11.0 for speed pot wiring.

06 TB-14 OPEN COLLECTOR OUTPUT

This selects the status indication for the open-collector output at TB-14. The terms “open” and “close” refer to the state of the internal transistor that activates the circuit. When the transistor is “closed”, TB-14 is at the same potential as TB-2, allowing current to flow.

- 01 **NONE:** Disables the open-collector output.
- 02 **RUN:** Closes upon a START command. Opens if the drive is in a STOP state, the drive faults, or input power is removed. DC braking is considered a STOP state.
- 03 **FAULT:** Closes if there is no fault condition. Opens if the drive faults, or input power is removed.
- 04 **INVERSE FAULT:** Closes if the drive faults. Opens if there is no fault condition.
- 05 **FAULT LOCKOUT:** Closes when input power is applied. Opens if three restart attempts are unsuccessful, or if input power is removed.

- 06 AT SET SPEED: Closes if the drive is within ± 0.5 Hz of the speed setpoint.
- 07 ABOVE PRESET SPEED #3: Closes if the output frequency exceeds PRESET SPEED #3 (Parameter 33). Opens if the output frequency is equal to or less than PRESET SPEED #3.
- 08 CURRENT LIMIT: Closes if the output current exceeds the CURRENT LIMIT setting. Opens if the output current is equal to or less than CURRENT LIMIT (see Parameter 25).
- 09 AUTOMATIC SPEED MODE: Closes if an AUTOMATIC (terminal strip) speed reference is active. Opens if a STANDARD (Parameter 5) speed reference is active.
- 10 REVERSE: Closes when reverse rotation is active. Opens when forward rotation is active (see Parameter 17 - ROTATION DIRECTION).
- 11 DB BRAKE: TB-14 becomes the "trigger" that activates the optional external Dynamic Braking module. Refer to the instructions included with the Dynamic Braking option.

NOTE: If the optional remote keypad is used, TB-14 is wired to the remote keypad and cannot be used for any of the above listed functions. In this case, this parameter should be set to NONE (01).

10 TB-13A FUNCTION SELECT

This selects the function of terminal TB-13A. Closing TB-13A to TB-11 (or opening in the case of settings 07 and 09) activates the selected function. The following functions can be selected:

- 01 NONE: Disables the TB-13A function.
- 02 SPEED POT: Selects a speed pot as the speed reference input. Refer to Section 11.0 for speed pot wiring.
- 03 PRESET SPEED #1: Selects PRESET SPEED #1 as the speed reference. The drive will operate at the frequency programmed into Parameter 31.
- 04 START FORWARD: Sets up the drive for a 3-wire start/stop circuit. Momentarily close TB-13A to TB-11 to start the drive, and momentarily open TB-1 to TB-11 to stop.
- 05 RUN REVERSE: Close TB-13A to TB-11 to run in the reverse direction, and open to stop. Close TB-1 to TB-11 to run in the forward direction and open to stop.
- 06 START REVERSE: Momentarily close TB-13A to TB-11 to start the drive in the reverse direction, and momentarily open TB-1 to TB-11 to stop. Parameter 17 - ROTATION must be set to FORWARD AND REVERSE (02), and TB-13C must be used for START FORWARD.
- 07 EXTERNAL FAULT: Sets TB-13A as a normally closed external fault input. Open TB-13A to TB-11 to trip the drive.

- 08 DB FAULT: Sets TB-13A as a dynamic braking fault input when used with the optional dynamic braking module. When this input is activated by the dynamic braking module, the drive will trip into a "dF" fault and the motor will coast to a stop. Refer to the instructions included with the Dynamic Braking option.
- 09 AUXILIARY STOP: When TB-13A is opened with respect to TB-11, the drive will decelerate to a STOP (even if STOP METHOD is set to COAST) at the rate set into ACCEL/DECEL #2 (Parameter 42).
- 10 ACCEL/DECEL #2: Selects the acceleration and deceleration time programmed into ACCEL/DECEL #2 (Parameter 42).

NOTE: If the optional remote keypad is used, functions 02, 04, 05, and 06 are disabled. Therefore, if this terminal is not being used for any of the other functions, it should be set to NONE (01).

11 TB-13B FUNCTION SELECT

This selects the function of terminal TB-13B. Closing TB-13B to TB-11 (or opening in the case of settings 07 and 09) activates the selected function. The following functions can be selected:

- 01 NONE: Disables the TB-13B function.
- 02 SPEED POT: Selects a speed pot as the speed reference input. Refer to Section 11.0 for speed pot wiring.
- 03 PRESET SPEED #2: Selects PRESET SPEED #2 as the speed reference. The drive will operate at the frequency programmed into Parameter 32.
- 04 DECREASE FREQ: Closing TB-13B to TB-11 will decrease the speed setpoint until the contact is opened. TB-13C must be programmed for INCREASE FREQ.
- 05 JOG FORWARD: Close TB-13B to TB-11 to JOG in the forward direction. The drive will run at PRESET SPEED #2 (Parameter 32) when in JOG mode.
- 06 JOG REVERSE: Close TB-13B to TB-11 to JOG in the reverse direction. The drive will run at PRESET SPEED #2 (Parameter 32) when in JOG mode.

WARNING!

When operating in JOG mode, the STOP signal and the AUXILIARY STOP function (see Parameters 10-12) **WILL NOT** stop the drive. To stop the drive, remove the JOG command.

JOG REVERSE will operate the drive in reverse rotation even if ROTATION DIRECTION (Parameter 17) is set to FORWARD ONLY.

- 07 EXTERNAL FAULT: Sets TB-13B as a normally closed external fault input. Open TB-13B to TB-11 to trip the drive.

- 08 DB FAULT: Used with the optional dynamic braking module. When this input is activated by the dynamic braking module, the drive will trip into a "dF" fault and the motor will coast to a stop. Refer to the instructions included with the Dynamic Braking option.
- 09 AUXILIARY STOP: When TB-13B is opened with respect to TB-11, the drive will decelerate to a STOP (even if STOP METHOD is set to COAST) at the rate set into ACCEL/DECEL #2 (Parameter 42).
- 10 ACCEL/DECEL #2: Selects the acceleration and deceleration time programmed into Parameter 42 - ACCEL/DECEL #2.

NOTE 1: If the drive is commanded to JOG while running, the drive will enter JOG mode and run at PRESET SPEED #2 (Parameter 32). When the JOG command is removed, the drive will STOP.

NOTE 2: If the optional remote keypad is used, functions 02 and 08 are disabled. Therefore, if this terminal is not being used for any of the other functions, it should be set to NONE (01).

12 TB-13C FUNCTION SELECT

This selects the function of terminal TB-13C. Closing TB-13C to TB-11 (or opening in the case of settings 06 and 08) activates the selected function. The following functions can be selected:

- 01 NONE: Disables the TB-13C function.
- 02 SPEED POT: Selects a speed pot as the speed reference input. Refer to Section 11.0 for speed pot wiring.
- 03 PRESET SPEED #3: Selects PRESET SPEED #3 as the speed reference. The drive will operate at the frequency programmed into Parameter 33.
- 04 INCREASE FREQ: Closing TB-13C to TB-11 will increase the speed setpoint until the contact is opened. INCREASE FREQ will only work when the drive is running. TB-13B must be programmed for DECREASE FREQ.
- 05 START FORWARD: Sets up the drive for a 3-wire start/stop circuit. Momentarily close TB-13C to TB-11 to start the drive, and momentarily open TB-1 to TB-11 to stop.
- 06 EXTERNAL FAULT: Sets TB-13C as a normally closed external fault input. Open TB-13C to TB-11 to trip the drive.
- 07 DB FAULT: Used with the optional dynamic braking module. When this input is activated by the dynamic braking module, the drive will trip into a "dF" fault and the motor will coast to a stop. Refer to the instructions included with the Dynamic Braking option.
- 08 AUXILIARY STOP: When TB-13C is opened with respect to TB-11, the drive will decelerate to a STOP (even if STOP METHOD is set to COAST) at the rate set into ACCEL/DECEL #2 (Parameter 42).

09 ACCEL/DECEL #2: Selects the acceleration and deceleration time programmed into ACCEL/DECEL #2 (Parameter 42).

NOTE: If the optional remote keypad is used, functions 02, 05, and 07 are disabled. Therefore, if this terminal is not being used for any of the other functions, it should be set to NONE (01).

14 CONTROL

01 TERMINAL STRIP ONLY: The drive will only respond to START and direction commands from the terminal strip.

02 REMOTE KEYPAD ONLY: The drive will only respond to START and direction commands from the optional remote keypad.

NOTE: When the optional remote keypad is used, TB-5 and TB-14 are wired to the remote keypad. Therefore, a speed pot cannot be used for speed control, and TB-14 cannot be used for status indication. Also, some of the functions on TB-13A, 13B, and 13C are disabled, and the Dynamic Braking option cannot be used.

17 ROTATION DIRECTION

01 FORWARD ONLY: The drive will only allow rotation in the forward direction. However, JOG REVERSE (see Parameter 11) will still operate even if FORWARD ONLY is selected.

02 FORWARD AND REVERSE: The drive will allow rotation in both directions.

18 TIME RANGE SELECT

This parameter is used as a time multiplier for Parameters 19, 20, 21, and 42. The values entered into those parameters are multiplied by the selected factor in this parameter.

- 01 x0.1 (Multiplies time by a factor of 0.1)
- 02 x1.0 (Multiplies time by a factor of 1.0)
- 03 x10.0 (Multiplies time by a factor of 10.0)

Example: If an acceleration time of 5.5 seconds is desired, set this parameter to 01 (x0.1 factor), and set ACCELERATION TIME (Parameter 19) to 55.

NOTE: When a new time multiplier is selected, the displays for Parameters 19, 20, 21, and/or 42 will change to maintain the same time value. For example, if the multiplier is x1.0, and ACCELERATION TIME is set to 30, the time value is 30 seconds. If the multiplier is then changed to x10.0, the ACCELERATION TIME display will change to 3 to maintain the time value of 30 seconds. If the display required to maintain the time value is out of the possible range (less than 1, higher than 99, or a decimal), the display will blink to indicate that it is not accurate.

19 ACCELERATION TIME

This sets the acceleration rate for all of the speed reference sources (keypad, speed pot, jog, MOP, and preset speeds). This setting is the time to accelerate from 0 Hz to the BASE FREQUENCY (Parameter 27). This parameter is affected by the setting of TIME RANGE SELECT (Parameter 18).

20 DECELERATION TIME

This sets the deceleration rate for all of the speed reference sources (keypad, speed pot, jog, MOP, and preset speeds). This setting is the time to decelerate from BASE FREQUENCY to 0 Hz. If the drive is set for COAST TO STOP (setting 01 or 02 in Parameter 04), this parameter will have no effect when a STOP command is given. This parameter is affected by the setting of TIME RANGE SELECT (Parameter 18).

21 DC BRAKE TIME

This sets the length of time that the DC braking voltage is applied to the motor. The DC BRAKE TIME should be set to the lowest value that provides satisfactory operation in order to minimize motor heating. This parameter is affected by the setting of TIME RANGE SELECT (Parameter 18).

22 DC BRAKE VOLTAGE

This sets the magnitude of the DC braking voltage, in percentage of the line voltage. The point at which the DC braking is activated depends on the selected STOP METHOD (Parameter 04):

If COAST WITH DC BRAKE is selected, braking is activated after a time delay of up to 2 seconds, depending on the output frequency at the time of the STOP command. In this case, the DC braking is the only force acting to decelerate the load.

If RAMP WITH DC BRAKE is selected, braking is activated when the output frequency reaches 0.2 Hz. In this case, the drive decelerates the load to a near stop and then DC braking is used to bring the load to a final stop.

23 MINIMUM FREQUENCY

This sets the minimum output frequency of the drive for all speed reference sources except the PRESET SPEEDS (Parameters 31-37).

When using a speed pot reference, this parameter also sets the drive speed that corresponds to the minimum analog input (0 VDC).

NOTE: If this parameter is changed while the drive is running, the new value will not take effect until the drive is stopped.

24 MAXIMUM FREQUENCY

This sets the maximum output frequency of the drive for all speed reference sources, and is used with MINIMUM FREQUENCY (Parameter 23) to define the operating range of the drive.

When using a speed pot reference, this parameter also sets the drive speed that corresponds to the maximum analog input (10 VDC).

NOTE: If this parameter is changed while the drive is running, the new value will not take effect until the drive is stopped.

25 CURRENT LIMIT

This sets the maximum allowable output current of the drive. The maximum setting is either 180% or 150%, depending on whether LINE VOLTAGE SELECTION (Parameter 01) is set to HIGH or LOW.

If the load demands more current than the CURRENT LIMIT setting, the drive will reduce the output frequency in an attempt to reduce the output current. When the overcurrent condition passes, the drive will accelerate the motor back up to the speed setpoint.

To set this parameter, divide the desired setting by 10 and enter that value. For example, if the desired setting is 150%, set this parameter to 15.

26 MOTOR OVERLOAD

The SM-Basic Series is UL approved for solid state motor overload protection, and therefore does not require a separate thermal overload relay for single motor applications. The drive contains an adjustable thermal overload circuit that protects the motor from excessive overcurrent. This circuit allows the drive to deliver up to 150% current for one minute. If the overload circuit “times out”, the drive will trip into an OVERLOAD fault (displayed as “PF”).

To set this parameter, subtract 1 from the desired setting and enter that value. For example, if the desired setting is 75%, set this parameter to 74. MOTOR OVERLOAD should be set to the ratio (in percent) of the motor current rating to the drive current rating in order to properly protect the motor.

Example: A 2 HP, 230 Vac drive with a 6.8 Amp rating is operating a 1 HP motor with a current rating of 4.0 Amps. Dividing the motor current rating by the drive current rating yields 59% ($4.0 / 6.8 = 0.59 = 59\%$), so this parameter should be set to 58 ($58 + 1 = 59\%$).

27 BASE FREQUENCY

The BASE FREQUENCY determines the V/Hz ratio by setting the output frequency at which the drive will output full voltage to the motor. In most cases, the BASE FREQUENCY should be set to match the motor’s rated frequency.

Example: A 230 Vac, 60 Hz motor requires a V/Hz ratio of 3.83 ($230 \text{ V} / 60 \text{ Hz} = 3.83 \text{ V/Hz}$) to produce full torque. Setting the BASE FREQUENCY to 60 Hz causes the drive to output full voltage (230 Vac) at 60 Hz, which yields the required 3.83 V/Hz. Output voltage is proportional to output frequency, so the 3.83 V/Hz ratio is maintained from 0 - 60 Hz, allowing the motor to produce full torque from about 2 Hz (below 2 Hz there is less torque due to slip) up to 60 Hz.

NOTE: If this parameter is changed while the drive is running, the new value will not take effect until the drive is stopped.

2 8 **FIXED BOOST**

FIXED BOOST increases starting torque by increasing the output voltage when operating below half of the base frequency, which increases the V/Hz ratio. For better out-of-the-box performance, SCN Series drives are shipped with a setting that is different from the factory default of 1%. Units rated 0.25 to 1 HP are set to 5.3%, units rated 1.5 to 2 HP are set to 4.4%, and 3 HP units are set to 3.6%.

29 **ACCELERATION BOOST**

ACCELERATION BOOST helps accelerate high-inertia loads. During acceleration, the output voltage is increased to increase motor torque. Once the motor reaches the new speed setpoint, the boost is turned off and the output voltage returns to the normal value.

30 **SLIP COMPENSATION**

SLIP COMPENSATION is used to counteract changes in motor speed (slip) caused by changes in load. In a standard AC induction motor, the shaft speed decreases as load increases, and increases as load decreases. By increasing or decreasing the output frequency in response to an increasing or decreasing load, the slip is counteracted and speed is maintained. Most standard NEMA B motors have a 3% slip rating.

To set this parameter, multiply the desired setting by 10 and enter that value. For example, if a setting of 2.5% is desired, enter 25 into this parameter.

31 - 37 **PRESET SPEED #1 - #7**

Preset speeds are activated by contact closures between TB-11 and TB-13A, 13B, and 13C. The TB-13 terminals must be programmed as preset speed selects using Parameters 10-12.

NOTE 1: Preset speeds can operate below the frequency defined by the minimum frequency parameter (Parameter 23).

Refer to the table below for activation of the preset speeds using the TB-13 terminals.

SPEED#	TB - 13A	TB - 13B	TB - 13C
1	CLOSED	OPEN	OPEN
2	OPEN	CLOSED	OPEN
3	OPEN	OPEN	CLOSED
4	CLOSED	CLOSED	OPEN
5	CLOSED	OPEN	CLOSED
6	OPEN	CLOSED	CLOSED
7	CLOSED	CLOSED	CLOSED

NOTE 2: When a TB-13 terminal is programmed for a function other than a preset speed select, it is considered OPEN for the table above.

Preset Speed #6 and #7 can also be used as skip frequencies to restrict the drive from operating at frequencies that cause vibration in the system. See Parameter 38 below.

38 SKIP BANDWIDTH

The SM-Basic drive has two skip frequencies that can be used to lock out critical frequencies that cause mechanical resonance in the system. Once SKIP BANDWIDTH is set to a value other than 0 Hz, the skip frequencies are enabled. When the skip frequency function is enabled, PRESET SPEED #6 and #7 are used as the skip frequencies. SKIP BANDWIDTH sets the range above the skip frequencies that the drive will not operate within.

Example: The critical frequency is 23 Hz, and it is desired to skip a frequency range of 3 Hz above and below the critical frequency (therefore the skip range is 20 to 26 Hz). PRESET SPEED #6 or #7 would be set to 20 Hz, and the SKIP BANDWIDTH would be set to 6 Hz.

If the drive is running at a speed below the skip range, and it is given a speed command that is within the skip range, the drive will accelerate to the start of the skip range (20 Hz in the example) and run at that speed until the speed command is greater than or equal to the "top" of the skip range. The drive will then accelerate through the skip range to the new speed. Likewise, if the drive is running at a speed above the skip range, and it is given a speed command that is within the skip range, the drive will decelerate to the "top" of the skip range (26 Hz in the example) and run at that speed until the speed command is less than or equal to the "bottom" of the skip range. The drive will then decelerate through the skip range to the new speed.

NOTE: PRESET SPEEDS #6 and #7 can still be used as preset speeds even if they are also being used as skip frequencies.

42 ACCEL / DECEL #2

This parameter sets the second acceleration and deceleration rate of the drive, which can be activated using terminals TB-13A, 13B, or 13C (Parameter 10, 11, or 12). This parameter is affected by the setting of TIME RANGE SELECT (Parameter 18).

44 PASSWORD

This allows the PASSWORD to be changed to any number between 00 and 99. Setting PASSWORD to 00 disables the password function.

NOTE: The factory default password is 25.

47 CLEAR FAULT HISTORY

- 01 MAINTAIN: Maintains the FAULT HISTORY (Parameter 50) entries for troubleshooting.
- 02 CLEAR: Erases the FAULT HISTORY (Parameter 50) entries.

4 8 PROGRAM SELECTION

This is used to select whether the drive will operate according to the user settings or the optional OEM default settings, and to reset the parameters to default settings. Refer to Section 13.2.

- 01 OPERATE WITH USER SETTINGS: The drive will operate according to the user settings. Operation in USER mode allows the parameter values to be changed to suit any application.
- 02 OPERATE WITH OEM DEFAULTS: The drive will operate according to the optional OEM default settings, which configure the drive for a specific application. When operating in OEM mode, the parameter values can be viewed, but not changed. If an attempt is made to change a parameter setting, the display will flash "GE". If the drive is not programmed with OEM default settings, the display will flash "GF" if this option is selected.
- 03 RESET OEM: Resets the user parameters to the OEM default settings. If the drive is not programmed with OEM default settings, the display will flash "GF" if this option is selected.
- 04 RESET 60: Resets the user parameters to the factory defaults for a 60 Hz base frequency.
- 05 RESET 50: Resets the user parameters to the factory defaults for a 50 Hz base frequency. Parameters 24 and 27 will reset to 50.0 Hz.
- 06 TRANSLATE: If an EPM from a drive with a previous parameter version is installed in a new drive, the new drive will function like the previous version drive, but none of the parameter settings can be changed ("cE" will be displayed if this is attempted). The TRANSLATE function converts the EPM to the new parameter version so that the parameters can be changed, but it also retains the old parameter settings so the new drive will operate like the old drive without having to re-program all of the parameters.

NOTE 1: If the user parameters are reset to the OEM defaults (using the RESET OEM option), and then OPERATE WITH USER SETTINGS is selected, the USER settings will be the same as the OEM default settings. This allows the drive to operate as if it was in OEM mode, but the parameter values can be changed. This is useful if some of the OEM default settings need to be fine-tuned for proper operation. The new parameter values are not actually stored as new OEM default settings however; they are simply stored as new USER settings. Therefore, if the parameters are reset to the OEM defaults again, the parameters that were changed will be reset to their "old" value. The optional EPM Programmer is required to change OEM default settings. Refer to Section 13.2.

NOTE 2: Only the TRANSLATE (06) function can be performed while the drive is running. The display will flash "Er" if an attempt is made to select any other function while the drive is running.

5 0 FAULT HISTORY

The FAULT HISTORY stores the last eight faults that tripped the drive. Refer to Section 16.0 - TROUBLESHOOTING for a list of the faults and possible causes.

Use the ▲ and ▼ buttons to scroll through the fault entries. The faults are stored from newest to oldest, with the first fault shown being the most recent.

The display will read “_ _” if the FAULT HISTORY does not contain any fault messages.

51 SOFTWARE VERSION

This displays the software version number for the control board software. This information is useful when contacting the factory for programming or troubleshooting assistance.

The software version is displayed in two parts which alternate. The first part is the software version, and the second part is the revision number. For example, if the display flashes “72” and “02”, this indicates that the drive contains the second revision of version 72 software.

52 DC BUS VOLTAGE

This displays the DC bus voltage in percent of nominal. Nominal DC bus voltage is determined by multiplying the drive’s nameplate input voltage rating by 1.4.

53 MOTOR VOLTAGE

This displays the output voltage in percent of the drive’s nameplate output voltage rating.

54 MOTOR LOAD

This displays the motor load in percent of the drive’s output current rating.

55 SPEED POT INPUT

This displays the level of the speed pot input signal at TB-5. A reading of 100% indicates that the maximum speed pot signal is present at TB-5.

NOTE: Parameters 52-55 can display values greater than 99. If the value is greater than 99, the display will alternate between “1 -” or “2 -” (for one hundred or two hundred) and the rest of the value. For example, if MOTOR LOAD is 137%, the display will alternate between “1 -” and “37”.

57 TERMINAL STRIP STATUS

This indicate the status of several terminals using the vertical segments of the LED display. An illuminated segment indicates that the particular terminal is closed to TB-2.

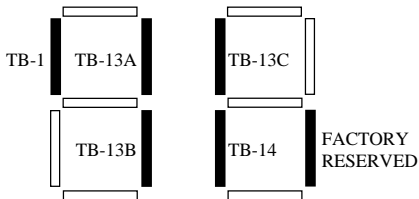

58 KEYPAD AND PROTECTION STATUS

This indicate the status of the buttons on the keypad, and the status of the protective circuitry in the drive, using the horizontal segments of the LED display. An illuminated segment indicates that the particular button is pressed, or the protective circuit is active.

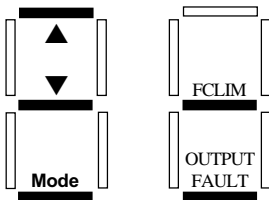

NOTE: FCLIM is an abbreviation for Fast Current Limit.

16.0 TROUBLESHOOTING

To aid in troubleshooting, Parameters 50 through 58 can be accessed without entering the PASSWORD. Simply press the **Mode** button twice to “skip” over the PASSWORD prompt, and “50” will be displayed to indicate that the parameter menu has been entered and Parameter 50 (FAULT HISTORY) can be viewed. The **▲** and **▼** buttons can then be used to scroll from Parameter 50 to Parameter 58. Once the desired parameter is found, press the **Mode** button to view its “contents”. When finished, press **Mode** to exit the parameter menu. An example is shown below:

Press **Mode** once

Display reads “00”

Upper right decimal point blinks

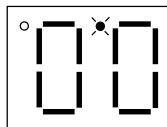

Press **Mode** again

Display reads “50” (FAULT HISTORY)

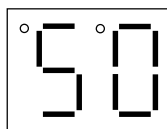

Use **▲** and **▼** to scroll to the desired parameter number

(In this example Parameter 54 has been selected, which is MOTOR LOAD)

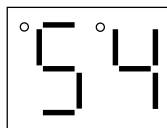

Press **Mode** to view parameter contents
(77 = 77% LOAD)

Upper right decimal point blinks

Press **Mode** again to exit

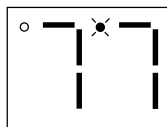

In the example above, Parameter 54 - MOTOR LOAD is being viewed. The “77” in the example indicates that the load on the motor is 77% of the output current rating of the drive.

The table below lists the fault conditions that will cause the drive to shut down, as well as some possible causes. Please contact the factory for more information on troubleshooting faults.

FAULT MESSAGES	
FAULT	DESCRIPTION & POSSIBLE CAUSES
AF	High Temperature Fault: Ambient temperature is too high; Cooling fan has failed (if equipped).
CF	Control Fault: A blank EPM, or an EPM with corrupted data has been installed. Perform a factory reset using Parameter 48 - PROGRAM SELECTION.
cF	Incompatibility Fault: An EPM with an incompatible parameter version has been installed. Either remove the EPM or perform a factory reset (Parameter 48) to change the parameter version of the EPM to match the parameter version of the drive.
dF	Dynamic Braking Fault: The drive has sensed that the dynamic braking resistors are overheating and shuts down to protect the resistors.
EF	External Fault: One of the TB-13 terminals is set as an External Fault input and that terminal is open with respect to TB-11. Refer to Parameters 10, 11 and 12.
GF	Data Fault: User data and OEM defaults in the EPM are corrupted.
HF	High DC Bus Voltage Fault: Line voltage is too high; Deceleration rate is too fast; Overhauling load. For fast deceleration or overhauling loads, dynamic braking may be required.
JF	Remote Keypad Fault: The communication between the SCN drive and the optional Remote Keypad has been lost. Check for proper wiring and/or noise.
LF	Low DC Bus Voltage Fault: Line voltage is too low.
OF	Output Transistor Fault: Phase to phase or phase to ground short circuit on the output; Boost settings are too high; Acceleration rate is too fast; Failed output transistor.
PF	Current Overload Fault: VFD is undersized for the application; Mechanical problem with the driven equipment.
SF	Single-phase Fault: Single-phase input power has been applied to a three-phase drive.
UF	Start Fault: Start command was present when the drive was powered up. Must wait 2 seconds after power-up to apply Start command if START METHOD is set to NORMAL.
F1	EPM Fault: The EPM is missing or damaged.
F2 - F9, Fo	Internal Faults: The control board has sensed a problem - consult factory.

To clear a fault, issue a STOP command on the terminal strip. The fault will only clear if the condition that caused the fault has passed. For example, if the drive trips on a LOW DC BUS VOLTAGE FAULT (LF) due to low input voltage, the fault cannot be cleared until the input voltage returns to a normal level.

If the drive is programmed to automatically restart after a fault (see Parameter 03), the drive will attempt to restart three times after a fault (the drive will not restart after CF, cF, GF, F1, F2-F9, or Fo faults). If all three restart attempts are unsuccessful, the drive will trip into FAULT LOCKOUT (LC), which requires a manual reset as described above.

17.0 SM-Basic DISPLAY MESSAGES

The following describes the various displays and messages that can appear on the SCN drive.

17.1 SPEED DISPLAY

If the drive is in a STOP state (indicated by "- -" on the display), and the keypad speed command is changed, the display will show the commanded speed, and the upper left decimal point will turn on solid. About five seconds after a change is made, the display will begin to alternate between the commanded speed value and the "- -" display. If the **Mode** button is pressed, the display will stop alternating and show the "- -" display only.

When the drive is given a START command, the displayed speed will start increasing as the drive accelerates up to the commanded speed. If the keypad speed command is changed while the drive is running, the display will show the commanded speed rather than the actual speed, until the actual speed reaches the commanded speed.

If the keypad speed command is changed faster than the drive can accelerate or decelerate, the upper left decimal point will blink to indicate that the the drive is accelerating or decelerating to the new speed. Once the actual speed reaches the commanded speed, the upper left decimal point will turn on solid for 5 seconds and then turn off to indicate that the commanded speed has been reached, and that the display is now showing the actual speed.

17.2 CHANGING THE SPEED REFERENCE SOURCE

When the speed source is changed while the drive is running, the display will flash the message for the new speed source to indicate that the new speed source is active. Also, if the drive is being controlled from a speed source other than the ▲ and ▼ buttons (speed pot, preset speed, etc), and one of the ▲ or ▼ buttons is pressed, the display will flash the present speed source message to indicate that the ▲ and ▼ buttons are invalid.

Example 1: The drive is running and the present speed source is the keypad. TB-13A is programmed to select a speed pot signal as the speed source. When TB-13A is closed to TB-11, the display will flash "EU" to indicate that the speed source has changed to the speed pot signal. If the contact between TB-13A and TB-11 is opened, the display will flash "CP" to indicate that the speed source has changed back to the ▲ and ▼ buttons.

Example 2: The speed source is a speed pot. If the ▲ or ▼ button is pushed, the display will flash "EU" to indicate that the present speed source is the speed pot and that the ▲ and ▼ buttons are invalid.

Refer to the table below for the possible speed reference source displays:

SPEED SOURCE DISPLAYS

DISPLAY	DESCRIPTION
CP	CONTROL PAD: Speed is set using the ▲ and ▼ buttons on the front of the drive.
EU	EXTERNAL VOLTAGE: Speed is controlled by a speed pot.
JG	JOG: The drive is in Jog mode, and the speed is set by Preset Speed #2 (Parameter 32).
OP	MOP (Motor Operated Pot): Contacts wired to two of the TB-13 terminals are used to increase and decrease the drive speed. See Parameters 10, 11, and 12.
P1 - P7	PRESET SPEEDS #1-7: Speed is set by the indicated Preset Speed (Parameters 31-37).

NOTE: The speed source displays will flash when the speed reference source is changed while the drive is running to indicate that the new speed reference source is active.

17.3 STATUS AND WARNING MESSAGES

STATUS AND WARNING MESSAGES

DISPLAY	DESCRIPTION
br	DC BRAKING: The DC braking circuit is activated.
cE	COMPATIBLE EPM: An EPM with a previous parameter version has been installed, and an attempt was made to change the programming. The drive will operate with the EPM installed, but the parameters cannot be changed. Refer to setting 06 (TRANSLATE) in Parameter 48.
CL	CURRENT LIMIT: The output current has exceeded the CURRENT LIMIT setting (Parameter 25) and the drive is reducing the output frequency to reduce the output current. If the drive remains in CURRENT LIMIT for too long, it can trip into a CURRENT OVERLOAD fault (PF).
Er	ERROR: Invalid data has been entered or an invalid command was attempted.
GE	"GE" will be displayed if an attempt is made to change the OEM default settings when the drive is operating in the OEM mode (see Parameter 48).
GF	If "GF" is displayed when a RESET OEM is attempted, it indicates that the OEM defaults in the EPM are corrupted. If "GF" is displayed upon power-up, it indicates that the OEM defaults and the user settings in the EPM are corrupted. Refer to Section 13.2.
LC	FAULT LOCKOUT: The drive has failed three restart attempts and now requires a manual reset.
SP	START PENDING: "SP" blinks during the interval between restart attempts.
	DECEL OVERRIDE (both upper decimal points blinking): The drive has stopped decelerating to avoid tripping into an HF fault due to regenerative energy from the motor.

18.0 USER SETTING RECORD

NO.	PARAMETER NAME	FACTORY DEFAULT	USER SETTING
01	LINE VOLTAGE	HIGH (01)	
02	CARRIER FREQUENCY	6 kHz (02)	
03	START METHOD	NORMAL (01)	
04	STOP METHOD	COAST (01)	
05	STANDARD SPEED SOURCE	KEYPAD (01)	
06	TB-14 OUTPUT	NONE (01)	
10	TB-13A FUNCTION SELECT	NONE (01)	
11	TB-13B FUNCTION SELECT	NONE (01)	
12	TB-13C FUNCTION SELECT	NONE (01)	
14	CONTROL	TERMINAL STRIP ONLY (01)	
17	ROTATION	FORWARD ONLY (01)	
18	TIME RANGE SELECT	x1.0 (02)	
19	ACCELERATION TIME	20 SEC	
20	DECELERATION TIME	20 SEC	
21	DC BRAKE TIME	0 SEC	
22	DC BRAKE VOLTAGE	0 %	
23	MINIMUM FREQUENCY	0 Hz	
24	MAXIMUM FREQUENCY	60 Hz	

NO.	PARAMETER NAME	FACTORY DEFAULT	USER SETTING
25	CURRENT LIMIT	180%	
26	MOTOR OVERLOAD	100%	
27	BASE FREQUENCY	60 Hz	
28	FIXED BOOST	1%	
29	ACCEL BOOST	0%	
30	SLIP COMPENSATION	0%	
31-37	PRESET SPEEDS	0 Hz	
38	SKIP BANDWIDTH	0 Hz	
42	ACCEL / DECEL #2	20 SEC	
44	PASSWORD	25	
47	CLEAR HISTORY	MAINTAIN (01)	
48	PROGRAM SELECTION	USER SETTINGS (01)	
50	FAULT HISTORY	(N/A)	
51	SOFTWARE CODE	(N/A)	
52	DC BUS VOLTAGE	(N/A)	
53	MOTOR VOLTAGE	(N/A)	
54	LOAD	(N/A)	
55	SPEED POT INPUT	(N/A)	
57	TB STRIP STATUS	(N/A)	
58	KEYPAD STATUS	(N/A)	



LEESON ELECTRIC CORPORATION

GRAFTON, WI 53024-0241 U.S.A. www.leeson.com (262) 377-8810 FAX (262) 377-9025

LEESON CANADA

TELEPHONE (905) 670-4770 FAX (905) 670-4378
MISSISSAUGA (TORONTO), ONTARIO L5T 2N7

Service Dept. FAX (262)-377-0090