

ACCU ELECTRIC MOTORS INC

USA: (888) 932-9183

CANADA: (905) 829-2505

- ✓ Over 100 years cumulative experience
- ✓ 24 hour rush turnaround / technical support service
- ✓ Established in 1993



The leading independent repairer of servo motors and drives in North America.

Visit us on the web:

www.servo-repair.com

www.servorepair.ca

www.ferrocontrol.com

www.sandvikrepair.com

www.accuelectric.com

Scroll down to view your document!

For 24/7 repair services :

USA: 1 (888) 932 - 9183

Canada: 1 (905) 829 -2505

Emergency After hours: 1 (416) 624 0386

Servicing USA and Canada

EDB480_E/GB
00459155

Lenze

Antriebstechnik

Operating Instructions

***Speed controllers
480 series***



These operating instructions are valid for controllers with the nameplate designation

| | | |
|-----|---|----|
| 481 | E | 3A |
| 482 | E | 3A |
| 483 | E | 3A |
| 484 | E | 3A |
| 485 | E | 3A |

Controller type

Chassis type

Hardware version + index

Edition of: 05/1996

revised: 10/2002

How to use this manual ...

To locate information on specific topics, simply refer to the table of contents at the beginning and to the index at the end of this manual.

The manual uses a series of different symbols to provide quick reference and to highlight important items.

This symbol refers to items of information intended to facilitate operation.

Notes which should be observed to avoid possible damage to or destruction of equipment.

Notes which should be observed to avoid health risks to the operating personnel.





Safety and application notes for drive controllers

(according to: Low Voltage Directive 73/23/EEG)

1. General

During operation, drive controllers may have, according to their type of protection, live, bare, in some cases also movable or rotating parts as well as hot surfaces.

For non-authorized removal of the required cover, for inappropriate use, for incorrect installation or operation, there is the risk of severe personal injury or damage to material assets.

Further information can be obtained from the documentation.

All operations concerning transport, installation, and commissioning as well as maintenance must be carried out **by qualified, skilled personnel** (IEC 364 and CENELEC HD 384 or DIN VDE 0100 and IEC report 664 or DIN VDE 0110 and national regulations for the prevention of accidents must be observed).

Qualified skilled personnel according to these basic safety information are persons who are familiar with the erection, assembly, commissioning, and operation of the product and who have the qualifications necessary for their occupation.

2. Application as directed

Drive controllers are components which are designed for installation into electrical systems or machinery.

When installing into machines, commissioning of the drive controllers (i.e. the starting of operation as directed) is prohibited until it is proven that the machine corresponds to the regulations of the EC Directive 89/392/EEG (Machinery Directive); EN 60204 must be observed.

Commissioning (i.e. starting of operation as directed) is only allowed when there is compliance with the EMC Directive (89/336/EEG).

The drive controllers meet the requirements of the Low Voltage Directive 73/23/EEG. The harmonized standards of the prEN 50178/ DIN VDE 0160 series together with EN 60439-1/DIN VDE 0660 part 500 and EN 60146/DIN VDE 0558 are applicable to drive controllers.

The technical data and information about the connection conditions must be obtained from the nameplate and must be observed in all cases.

3. Transport, storage

Notes on transport, storage and appropriate handling must be observed.

Climatic conditions must be observed according to prEN 50178.

4. Erection

The devices must be erected and cooled according to the regulations of the corresponding documentation.

The drive controllers must be protected from inappropriate loads. Particularly during transport and handling, components must not be bent and/or insulation distances must not be modified. Touching of electronic components and contacts must be avoided.

Drive controllers contain electrostatically sensitive components which can easily be damaged by inappropriate handling. Electrical components must not be damaged or destroyed mechanically (health risks are possible!).

5. Electrical connection

When working on live drive controllers the valid national regulations for the prevention of accidents (e.g. VBG 4) must be observed.

The electrical installation must be carried out according to the appropriate regulations (e.g. cable cross-sections, fuses, PE connection). More detailed information is included in the documentation.

Notes concerning the installation in compliance with EMC - like screening, grounding, arrangement of filters and laying of cables - are included in the documentation of the drive controllers. These notes must also be observed in all cases for drive controllers with the CE mark. The compliance with the required limit values demanded by the EMC legislation is the responsibility of the manufacturer of the system or machine.

6. Operation

Systems where drive controllers are installed must be equipped, if necessary, with additional monitoring and protective devices according to the valid safety regulations, e.g. law on technical tools, regulations for the prevention of accidents, etc. Modifications of the drive controllers and the operating software are prohibited.

After disconnecting the drive controllers from the supply voltage, live parts of the controller and power connections must not be touched immediately because of possibly charged capacitors. For this, observe the corresponding labels on the drive controllers.

During operation, all covers and doors must be closed.

7. Maintenance and servicing

The manufacturer's documentation must be observed.

This safety information must be preserved!

The product-specific safety and application notes in these operating instructions must also be observed!

Contents

| | | |
|----------|--|-----------|
| 1 | Features of the 480 series of controllers | 5 |
| 2 | Technical data | 6 |
| 2.1 | Controller-specific data | 6 |
| 2.2 | Dimensions | 7 |
| 2.3 | Scope of supply | 8 |
| 2.4 | Application as directed | 8 |
| 3 | Accessories | 9 |
| 4 | Installation | 13 |
| 4.1 | Installation | 13 |
| 4.2 | Connection | 13 |
| 4.2.1 | Installation corresponding to EMC | 15 |
| 4.2.2 | CE-typical drive system | 16 |
| 4.3 | Connection diagram | 19 |
| 4.4 | Special field voltages | 20 |
| 4.4.1 | Field voltage $V_F = 0.9 \times V_{L1, L2}$ | 20 |
| 4.4.2 | Field connection via autotransformer | 20 |
| 4.4.3 | Field connection via transformer | 20 |
| 4.5 | Mains voltage $V_{3L} < 340 \text{ V}$ | 21 |
| 4.6 | Additional terminals | 22 |
| 4.7 | Replacing the fuses | 22 |
| 5 | Commissioning | 23 |
| 5.1 | Setting the current limit | 23 |
| 5.2 | Armature voltage control with "I x R compensation" | 24 |
| 5.3 | Speed control with tacho feedback | 25 |
| 6 | Switching operation | 26 |
| 6.1 | Controller enable | 26 |
| 6.2 | Controller inhibit | 26 |
| | Index | 27 |

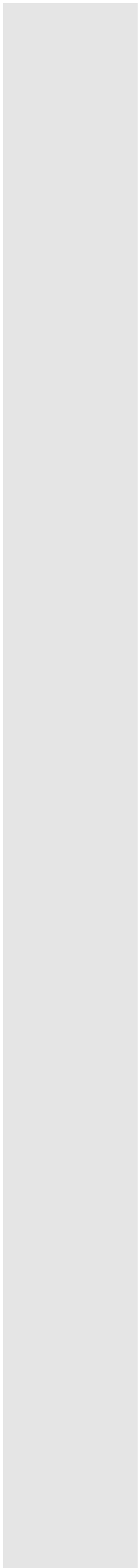

1 Features of the 480 series of controllers

The 480 series of controllers comprises five fully-controlled two-quadrant controllers with output powers from 10 kW to 115 kW. The most important features include:

- Compact controllers with isolated heatsink
- High response thanks to six-pulse three-phase bridge and leakage current adaptation
- Operation with tacho or armature voltage feedback with "I · R compensation"
- Isolation of control electronics and power stage when tacho feedback is used
- Self-synchronization of the phase shifter for 50...60-Hz mains
- Mains connection independent of the phase sequence
- High interference margin due to integrated synchronizing filter
- Burst-gate thyristor control in the power stage
- Reliable operation also for mains voltage fluctuations and short-term mains failures due to static and dynamic voltage monitoring
- Display of the operating states using LEDs
- Option board can be retrofitted:
 - Set-value integrator 2003
 - Winding calculator 1071
- Compliance with the CE directives for the erection of a CE conform drive system

2 Technical data

2.1 Controller-specific data

| Type | | 481 | 482 | 483 | 484 | 485 |
|-------------------------------|-------------------------|---|----------|----------|----------|----------|
| Output power | P_{el} [kW] | 10.5 | 23 | 46 | 92 | 115 |
| Mains frequency | f [Hz] | 50...60 | | | | |
| Mains voltage | V_{3L} [V] | 340...460 | | | | |
| Armature voltage | V_A | 460 V for $V_{3L} = 400$ V ($1.15 \times V_{3L}$) | | | | |
| Armature current | I_A [A] | 23 | 50 | 100 | 200 | 250 |
| Field voltage | V_F | $0.9 \times V_{L1, L2 (N)}$ | | | | |
| Max. field current | I_F [A] | 8 | | | | 10 |
| Rated master voltage | V_{LN} [V] | 10...180 | | | | |
| Rated tacho voltage | V_{TN} [V] | 10...180 | | | | |
| Operating ambient temperature | T_u [°C] | 0...45 | | | | |
| Set-value potentiometer Type | R | 10k Ω /1W _{in} . ER00322194 | | | | |
| Field fuse Type | F 101 | FF16A/500V EFSFF0160AWB | | | | |
| Electronics fuse Type | F 102 F 103 F 104 | F1A/450V 5 x 25 EFSF_0010AVF | | | | |
| Weight approx. | m [kg] | 4.5 | 5.5 | 8.5 | 10.5 | 13 |
| Chassis type E | | 33.481_E | 33.482_E | 33.483_E | 33.484_E | 33.485_E |

2.2 Dimensions

Controllers of the 480 series without protective cover:

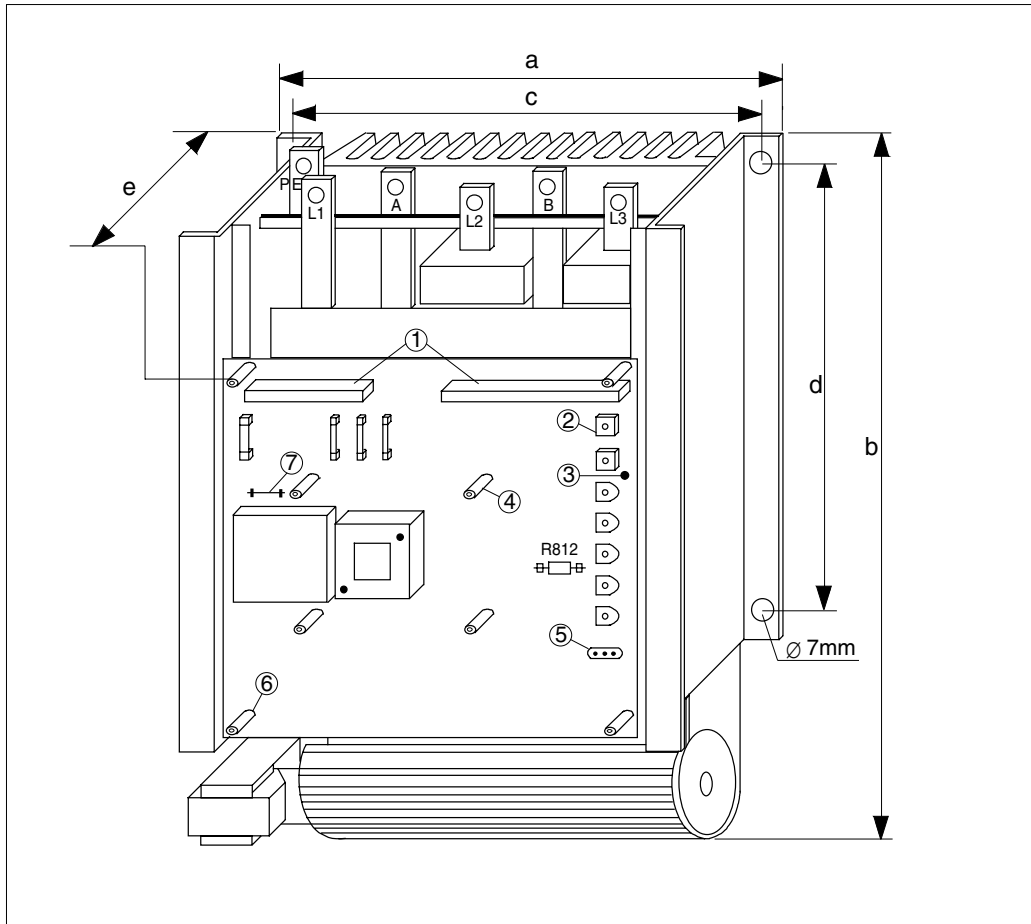

Explanations

| | |
|------------------------|--|
| ① | Connecting terminals for field and electronics |
| ② | Trimmers n_{\max} , $U_{\text{Leit grob}}$, $U_{\text{Leit fein}}$, n_{\min} , V_p , $I \times R$, I_{\max} |
| ③ | Measuring point "M1" |
| ④ | Spacer "M3" for the attachment of the option boards |
| ⑤ | LEDs $\pm V_{CC}$, RSP, I_{\max} |
| ⑥ | Spacer "M4" for the fixing of the protective cover |
| ⑦ | Jumper "BR1" |
| R812 | 2.2-k Ω resistor on soldering points |
| F101 | Field fuse |
| F102 F103 F104 | Electronics fuses |
| L1, L2, L3, PE A, B | Power connections |

| Type | a [mm] | b [mm] | c [mm] | d [mm] | e [mm] ¹⁾ |
|------|-----------|-----------|-----------|-----------|-------------------------|
| 481 | 240 | 220 | 225 | 200 | 175 |
| 482 | 240 | 300 | 225 | 280 | 175 |
| 483 | 285 | 380 | 271 | 235 | 200 |
| 484 | 285 | 465 | 271 | 310 | 200 |
| 485 | 285 | 535 | 271 | 380 | 230 |

¹⁾ The dimension (e) is the installation height of the base controller including protective cover.

2.3 Scope of supply

The scope of supply includes:

- the controller 48x_E
- set-value potentiometer 10 k Ω
- the operating instructions

2.4 Application as directed

- The controllers of the types 48x are electrical equipment for the installation into control cabinets of electrical systems or machinery.
- The controllers of the types 48x are designed as components for the control of speed-variable drives with separately-excited DC motors or for the assembly with other components to form a machine or system.
- Drive systems with drive controllers 48x which are installed according to the definition of a CE-typical drive system (see chapter 4.2.2), correspond to the EC EMC Directive and the standards mentioned below.
- CE-typical drive systems are
 - suitable for the operation on public and non-public mains and
 - provided for industrial applications.
- Because the ground potential reference of the RFI filters the CE-typical drive system which is described is not suitable for the connection to IT mains (mains without ground potential reference).
- The drive controllers are not domestic appliances, but are designed for drive systems for commercial use.
- The controllers of the types 48x themselves are not machines according to the EC Machinery Directive. The final function is only determined when integrated into the machine construction of the user.
- The user must consider measures in his machine construction which limit the consequences in case of malfunction or failure of the drive controller (increase of the motor speed or sudden motor stop) so that hazards for persons or material assets cannot be caused, such as:
 - further independent equipment for the monitoring of safety-relevant variables (speed, travel, end positions, etc.)
 - electrical or non-electrical protective equipment (latching or mechanical blocking)
 - measures covering the complete system

3 Accessories

The following components can be ordered separately:

- RFI filter
- Mains choke
- Mains fuses and fuse holders
- Knob and scale for set-value potentiometer
- Option board 2003 and 1071

| Type | 481 | 482 | 483 | 484 | 485 |
|---|--|--|---------------------------------------|---|---|
| RFI filter Type | EZF3_025A001 | EZF3_050A001 | EZF3_110A001 | EZF3_180A001 | EZF3_280A001 |
| RFI filter for the separate neutral conductor of the field supply Type | EZF1_009A001 | | | | EZF1_018A001 |
| AC mains choke L_k Type | 3 x 0.88mH / 35A ELN3_0088H035 | 3 x 0.75mH / 45A ELN3_0075H045 | 3 x 0.38mH / 85A ELN3_0038H085 | 3 x 165 μ H / 170A ELN3_0017H170 | 3 x 115 μ H / 270A ELN3_0011H270 |
| Mains fuse F1, F2, F3 Type | FF25A/600 V 14 x 51 EFSFF0250AYH | FF50A/600 V 22 x 58 EFSFF0500AYI | FF100A/660 V 00/80 EFSFF1000AXL | FF200A/660 V 00/80 EFSFF2000AXL | FF315A/660 V 00/80 EFSFF3150AXL |
| Fuse holder Type | EF00332721 | EF00357279 | EF00326308 | EF00326308 | EF00326308 |

Mains choke

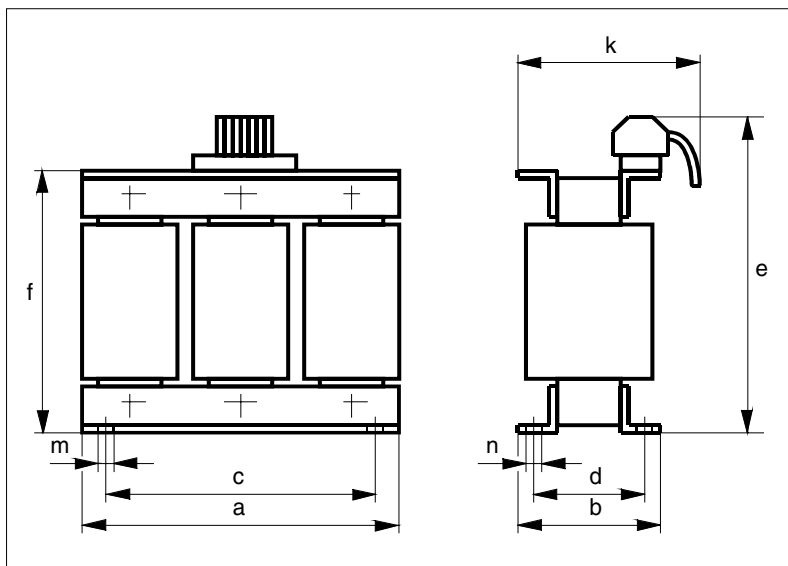

| Type | 481 | 482 | 483 | 484 | 485 |
|-------------|---------------|---------------|---------------|---------------|---------------|
| Mains choke | | | | | |
| Type | ELN3_0088H035 | ELN3_0075H045 | ELN3_0038H085 | ELN3_0017H170 | ELN3_0011H270 |
| L [mH] | 3 x 0.88 | 3 x 0.75 | 3 x 0.38 | 3 x 0.165 | 3 x 0.115 |
| I [A] | 35 | 45 | 85 | 170 | 270 |
| a [mm] | 180 | 180 | 228 | 264 | 300 |
| b [mm] | 91 | 91 | 111 | 128 | 140 |
| c [mm] | 161 | 161 | 206 | 240 | 274 |
| d [mm] | 74 | 74 | 94 | 107 | 114 |
| e [mm] | 225 | 225 | 273 | 257 | 290 |
| f [mm] | 165 | 165 | 205 | 237 | 265 |
| k [mm] | 120 | 120 | 140 | 166 | 190 |
| m [mm] | 6.3 | 6.3 | 6.3 | 8.3 | 8.3 |
| n [mm] | 11 | 11 | 11 | 16 | 16 |
| Weight [kg] | 9.8 | 9.8 | 19.5 | 32.2 | 43.2 |

RFI filter ($V_{\max} = 440 \text{ V} \pm 0 \%$)

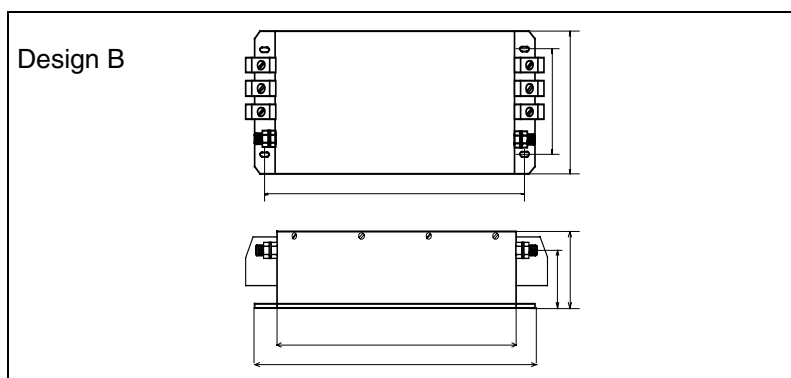
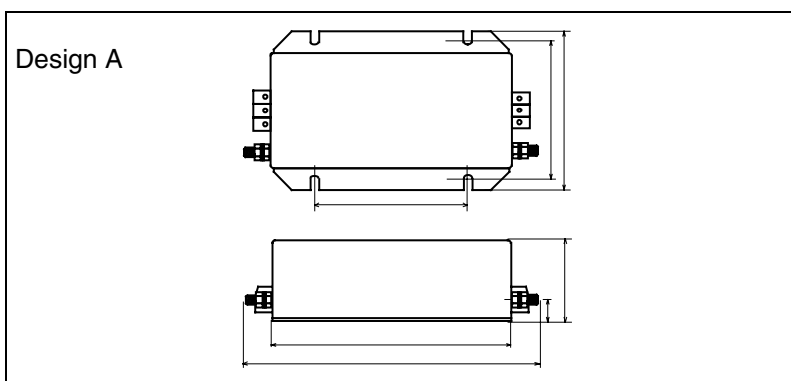

| Type | 481 | 482 | 483 | 484 | 485 |
|-------------------|--------------|--------------|--------------|--------------|--------------|
| Filter Type | EZF3_025A001 | EZF3_050A001 | EZF3_110A001 | EZF3_180A001 | EZF3_280A001 |
| Rated current [A] | 25 | 50 | 110 | 180 | 280 |
| Design | A | A | B | B | B |
| a [mm] | 250 | 250 | 436 | 537 | 742 |
| b [mm] | 150 | 150 | 170 | 180 | 260 |
| c [mm] | 135 | 135 | 130 | 156 | 220 |
| d [mm] | 200 | 200 | 350 | 360 | 530 |
| e [mm] | 65 | 65 | 90 | 132 | 153 |
| f [mm] | 17 | 17 | 70 | 88 | 103 |
| g [mm] | 115 | 115 | 375 | 470 | 660 |
| Fixing | 4 x M6 | 4 x M6 | 4 x M10 | 4 x M10 | 4 x M10 |
| Weight [kg] | 3.0 | 3.1 | 9.5 | 13.0 | 28.0 |

RFI filter for the separate neutral conductor of the field supply ($V_{\max} = 250 \text{ V} \pm 0 \%$)

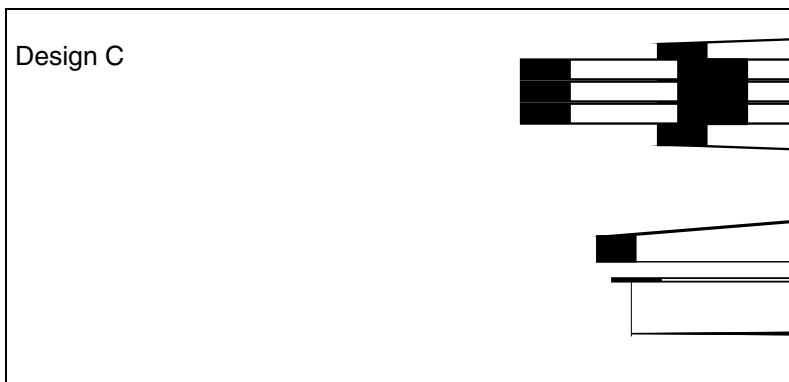

| Type | 481 ... 484 | 485 |
|-------------------|--------------|--------------|
| Filter Type | EZF1_009A001 | EZF1_018A001 |
| Rated current [A] | 9 | 18 |
| Design | C | C |
| a [mm] | 120 | 123 |
| b [mm] | 55 | 85 |
| c [mm] | 50 | 39 |
| d [mm] | 110 | 108 |
| e [mm] | 45 | 50.8 |
| f [mm] | 95 | 100 |
| Fixing | 4 x M3 | 4 x M4 |
| Weight [kg] | 0.6 | 0.7 |

4 Installation

4.1 Installation

When installing into an enclosure ensure sufficient ventilation. The ambient temperature must not exceed +45 °C. Install the controller with the terminals at the top.

External operating elements (e.g. switch, fuses) must not be arranged close (≤ 250 mm) to the controller 480. If this distance is not observed, a suitable cover must be provided in order to avoid accidental contact with the controller board.

4.2 Connection

- The controllers contain electrostatically sensitive components. Prior to assembly and servicing the personnel must be free of electrostatic charges. Discharging is possible by touching the PE fixing screw or another grounded metal part in the control cabinet.
- If you use residual current devices:
 - The controllers have an internal mains rectifier. After a short-circuit to frame a DC fault current may prevent the tripping of the residual current device. Therefore, take additional measures like zeroing or use universal current e.l.c.b.
 - Observe for the dimensioning of the release current of e.l.c.b. that capacitive compensating currents of the cable screens and RFI filters occurring during normal operation may cause false tripping.
 - Note for the use of universal e.l.c.b.:
The preliminary standard prEN50178 (in the past VDE0160) about the use of universal e.l.c.b. has been decided by the German committee K226.
The final decision about the use in compliance with the standard is made by the CENELEC/CS (European Committee for Electrotechnical Standardization) in Brussels.
Further information on the use of universal current e.l.c.b. can be obtained from the supplier.

The phase sequence for the connection of the power terminals L1, L2, L3 is arbitrary.

All cables from and to the controller must be screened. Connect the screening at both ends, close to the cable ends, to the central PE connection. When using the supplied set-value potentiometer, the mechanical screw fixing must have an additional PE connection and the connections must be insulated and covered.

Caution!

In the operating mode "armature voltage control with I x R compensation" all control terminals carry mains potential.



It is therefore necessary that all input and output signals required for the control of the controller are, electrically, safely separated by measures outside the controller and have another protection against direct contact (double basic insulation).

For operation with tacho voltage feedback the control electronics has a simple basic insulation. Take measures outside the controller to ensure that input and output signals of the control have a double basic insulation.

The protective cover above the controller board reduces the hazard of accidental touching of live components. For the assembly and during commissioning the cover must be removed.



Caution!

Removal of the protective cover and all settings must only be carried out by qualified skilled personnel.

With removed cover, there is increased danger of accidental contact with bare, live components on the controller board.

The protective cover must only be attached and removed when no voltage is applied. The cover must be replaced after setting.

The temperature of the power semiconductors in the 483...485 units is monitored by a thermal sensor. If the heatsink temperature exceeds the limit $\vartheta_{limit} = 90 \text{ }^{\circ}\text{C}$ the controller sets controller inhibit "RSP" and the firing pulses are set to the inverter limit position. An electrical latching also prevents an automatic reconnection after the controller has cooled. The latching can only be eliminated by disconnection and reconnection of the mains!

Notes for the connection of controller and motor

| Lenze controller | | Motor (acc. to DIN 42017 / VDE 0530 part 8) | | |
|--------------------------------|--------------|---|-----------------------|--|
| Function | Termina l | Termina l | other designations | Motor type |
| Armature voltage | + A | 1B1 | A1 | DC motor uncompensated with commutating pole winding |
| | - B | 2B2 | B2, A2 | |
| Excitation voltage | + I | F1 | E1 | |
| | - K | F2 | E2 | |
| Armature voltage | + A | 1C1 | A1 | DC motor compensated with commutating pole winding |
| | - B | 2C2 | C2 | |
| Excitation voltage | + I | F1 | E1 | |
| | - K | F2 | E2 | |
| Armature voltage | + A | A1 | | Permanent magnet motor |
| | - B | A2 | | |
| DC tacho | + 3 | 2A1 | | |
| | - 4 | 2A2 | | |
| AC tacho with rectification | + 3 | 3A1 | | |
| | - 4 | 3A2 | | |

4.2.1 Installation corresponding to EMC

- Controllers cannot be operated on their own. The EMC of controllers on their own cannot be tested. Only the integration of the controllers into a drive system allows a test whether the objectives of the EC EMC Directive are met and whether the device are in compliance with the law about the electromagnetic compatibility of equipment.
- Lenze has done conformity tests with the controllers of the types 48x in certain, defined drive systems. These tested drive systems are called "**CE-typical drive system**" in the following.
- Therefore, the user of the controller has the choice,
 - either to determine the system components and their integration into a drive system himself and to determine the conformity under his own responsibility
 - or to install the drive system according to the CE-typical drive system as tested by the manufacturer of the controller and declared to be in compliance.
- If you observe the following measures you can assume that EMC problems caused by the drive system will not arise during the operation of the machine and the EMC Directive and the EMC law are satisfied.
- For any other installation, e.g.
 - use of unscreened cables,
 - use of collective RFI filters instead of the allocated RFI filters,
 - omission of mains chokesthe machine or system must be tested whether it is compliance with the EC EMC Directive and the EMC limit values are considered.
- **The compliance with the EMC Directive in the machine application is the responsibility of the user.**

4.2.2 CE-typical drive system

Components of a CE-typical drive system

| System component | Specification |
|---|--|
| Controller | Controller of the types 48x |
| RFI filter | Data and allocation see chapter 3 "Accessories" |
| Mains choke | Data and allocation see chapter 3 "Accessories" |
| Armature and field cable | Screened power cable with tinned E-CU braid with 85 % optical coverage. Tested maximum length: 50 m |
| Mains cable between RFI filter and mains choke and between mains choke and controller | As from cable length of 200 mm: screened power cable with tinned E-CU braid with 85 % optical coverage.. |
| Control cables | Screened signal cable type LIYCY |
| Motor | DC motor with separate excitation Lenze series GFQ, GFR or similar |

Note:

Controller, RFI filter, and mains choke are located on one mounting plate.

Installation of the CE typical drive system

The electromagnetic compatibility of a drive system depends on the type and accuracy of the installation.

Take special care with

- filters
- screening
- grounding

Filters

- Only use the RFI filters and mains chokes allocated to the controllers
 - RFI filters reduce non-permissible high-frequency interferences to a permissible value.
 - Mains chokes reduce low-frequency interference which depends primarily on the motor cables and their length.

For motor cables which are longer than 50 m additional measures are required.

Screening

- Screen all cables from and to the controller.
- Make sure that motor cables are separated from signal and mains cables when laying the cables.
- Avoid a common terminal board for mains input and motor output.
- The cables must be laid as close as possible to the reference potential. Dangling cables are like antennas.

Grounding

- Ground all conductive metal components (controllers, RFI filters, mains chokes) by suitable cables from a central grounding point (PE bar).
- Observe the minimum cross-sections prescribed in the safety information. However, for EMC the surface of the contact is important and not the cross-section.

Assembly

- Make the contact from controller, RFI filter, and mains chokes to the grounded mounting plate with as large a surface as possible. Zinc-coated mounting plates allow long-lasting contacts. For painted plates the paint of the mounting plates must be removed in all cases.
- If you use several mounting plates:
 - Make a conductive connection of the mounting plates with as large a surface as possible (e.g. using copper bands).
- Connect the screen of the armature and field cable to the mounting plate with as large a surface as possible:
 - Recommendation: Make the large-surface connection of the screens to the mounting plate with earthing clamps on bare metal mounting surfaces.

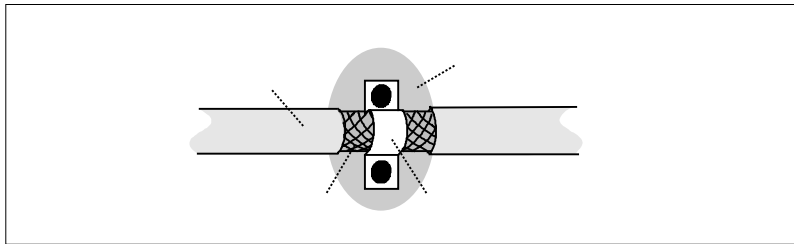

- If there are contactors, motor protection switches, or terminals in the armature cable:
 - Contact of the screens of the connected cables to each other and to the mounting plate with as large a surface as possible.
- In the terminal box, connect the screen of the motor to PE:
 - Metal cable glands at the motor terminal box ensure a large-surface connection of the screen to the motor housing.
- If the total length of the mains cable between RFI filter and mains chokes and controller exceeds 200 mm:
 - Screen mains cables
 - Connect the screen of the mains cables to the mounting plate with as large a surface as possible.
- Connect the screen of the control cables to the mounting plate with as large a surface as possible.
- If you use drive systems with the types 48x in residential areas:
 - Check the compliance with radio interference voltage level (EN55022 class B) at the supply location of the operating area.
 - Check the permissible radio interference emission (EN55022 class B) at the supply location of the operating area.

Please note:

If devices which do not comply with the CE requirement concerning the noise immunity EN 500882-2 are operated close to the controllers, an electromagnetic disturbance of these devices by the controllers is possible.

Part of the CE-typical drive system which is located on the mounting plate

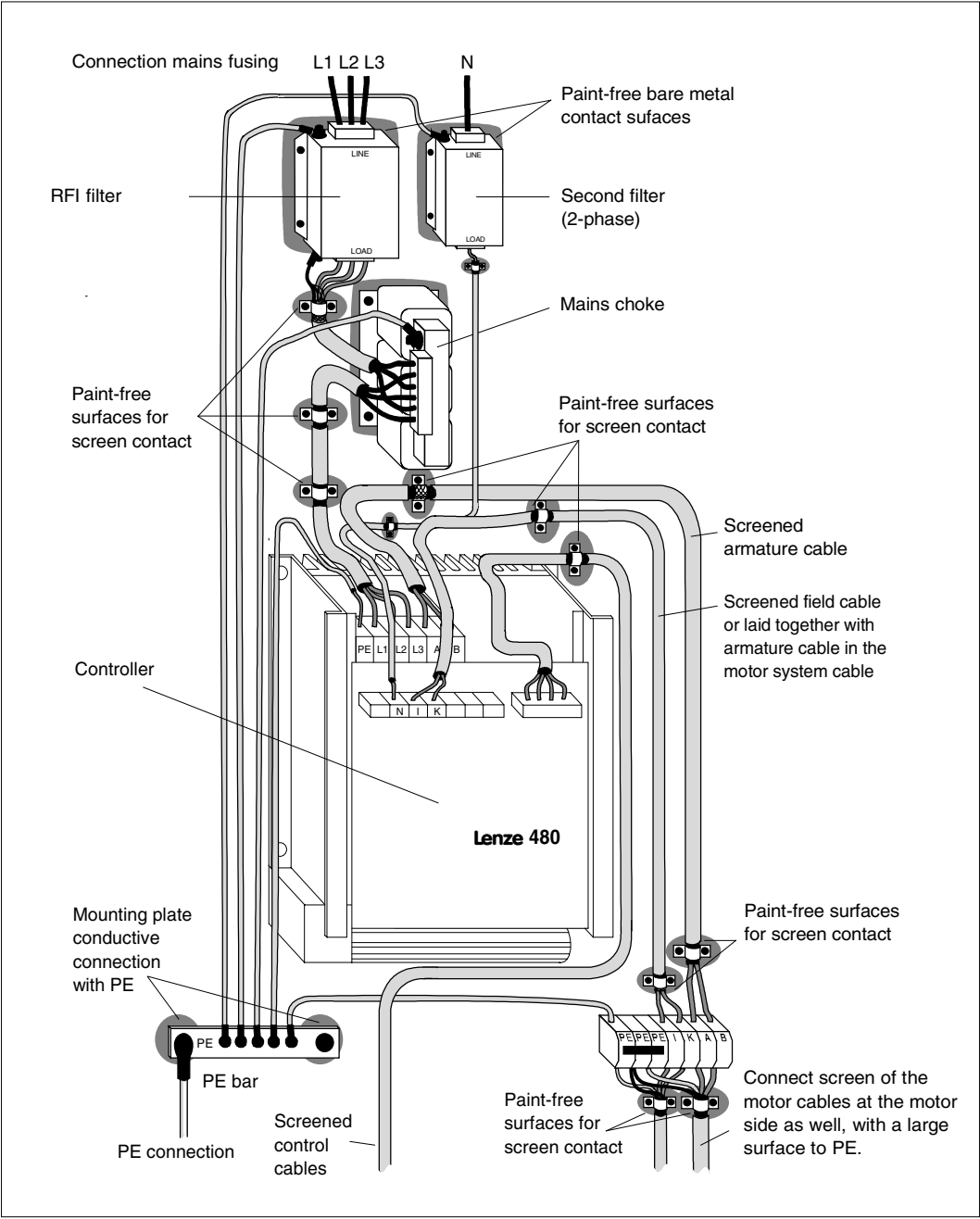

4.3 Connection diagram

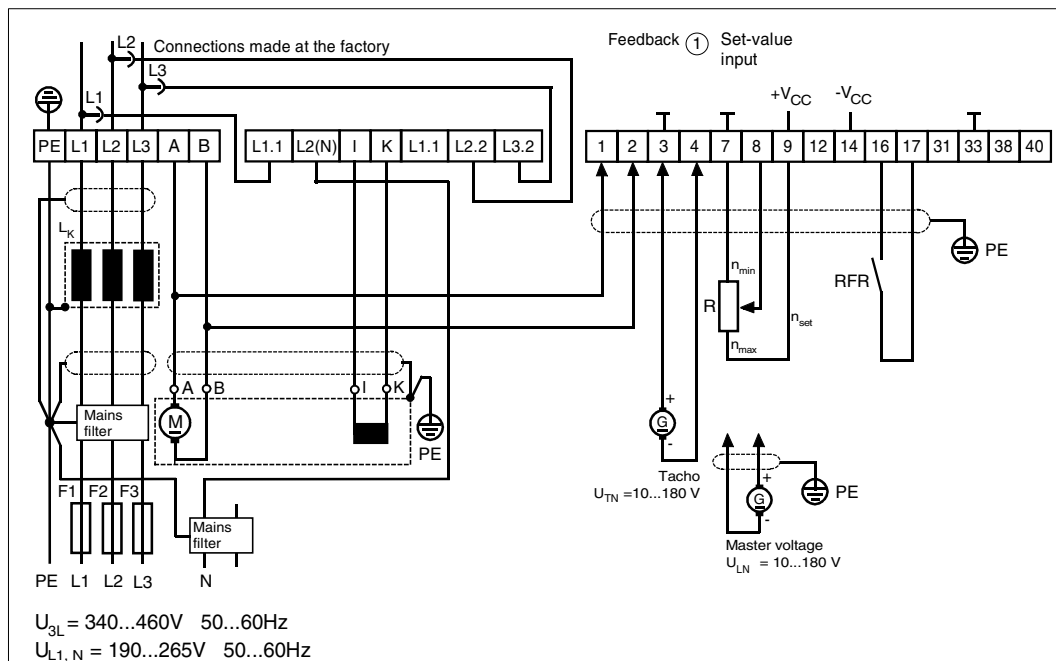

Explanations

| | |
|---|---|
| ① | Only the feedback system used can be connected at terminals 1/2 or 3/4. |
|---|---|

Note

1. If the signals must be changed over via relays, use suitable relay contacts (e.g. gold-plated contacts).
2. When switch RFR is closed the controller is enabled.

4.4 Special field voltages

4.4.1 Field voltage $V_F = 0.9 \times V_{L1, L2}$

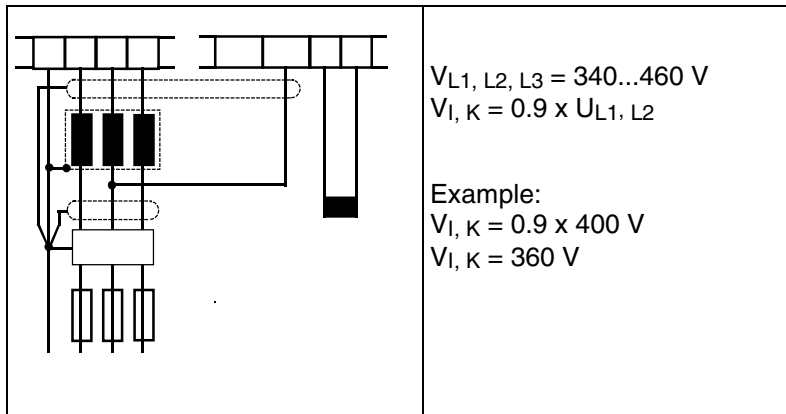

4.4.2 Field connection via autotransformer

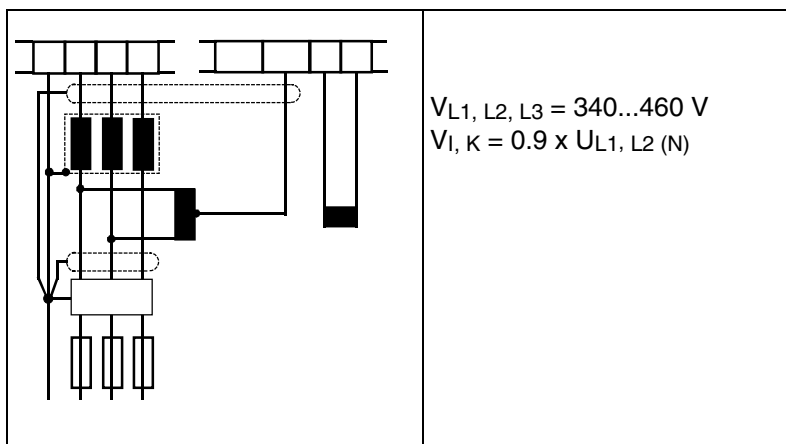

4.4.3 Field connection via transformer

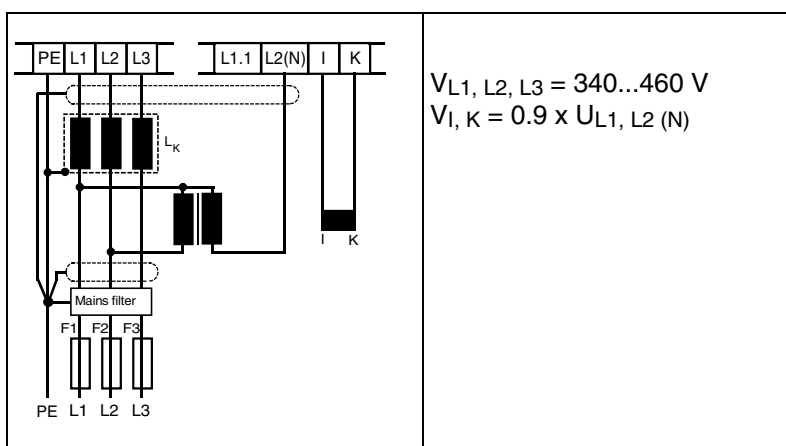

4.5 Mains voltage $V_{3L} < 340\text{ V}$

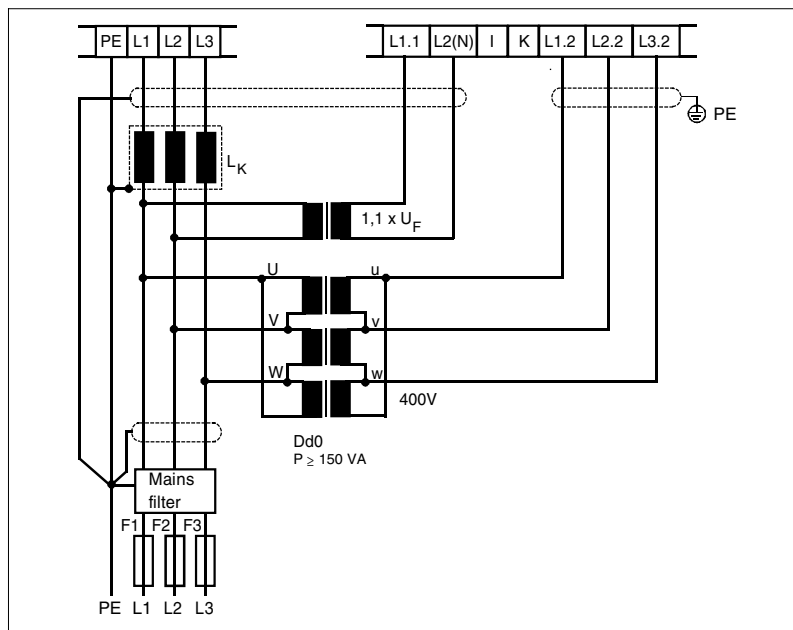

If the mains voltage is lower than 340 V the control electronics must be supplied separately via the step-up transformer as shown in the illustration.

Remove the connections between terminals L1.2, L2.2 and L3.2 and the 4082 board. Remove the jumper "BR1" on the 4081 board (see chapter 2.2 "Dimensions").

Caution!

This modification must only be carried out by qualified skilled personnel. After removing the jumpers the protective cover must be reassembled.

The correct phase sequence for the connection of the AC transformer must be observed in all cases!



4.6 Additional terminals

| Terminal designation | Meaning |
|----------------------|--|
| 9 | +V _{CC} = +15 V= stabilized. +V _{CC} can be loaded externally with 15 mA. |
| 12 | Input current controller; R _i ≈ 10 kΩ, U _{iset} = 0... -10 V= (-10 V ≙ I _{Amax}) |
| 14 | -V _{CC} = -15 V= stabilized. -V _{CC} can be loaded externally with 15 mA. |
| 31 | Output actual armature current. The output terminal 31 supplies an output voltage proportional to the armature current. U ₃₁ ≈ 5 V corresponds to the rated controller current. This output can be loaded with a maximum of 3 mA. The output resistance is R _i = 1 kΩ. |
| 38 | Freely assignable speed controller input Terminal 38 leads to the summation point of the speed controller via R _i ≈ 50 kΩ. The permissible input voltage range is between -10 V and +10 V. |
| 40 | Output speed controller; R _i ≈ 200 Ω. Terminals 40 and 12 are connected internally via a resistor 2.2 kΩ (R812 on soldering posts, see chapter 2.2 "Dimensions"). Caution! If an external set-value potentiometer is connected, this resistor must be removed. |

Connection of a potentiometer to limit the current set-value:

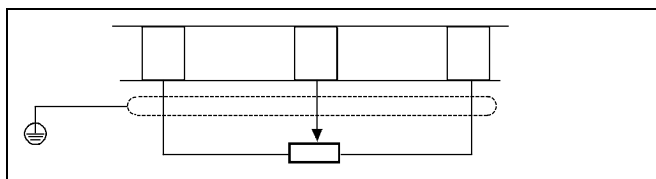

4.7 Replacing the fuses

The fuses protect the controller from non-permissible operating conditions. After the release of such a protective function, the controller and the system must be checked for further faults before replacing the fuses.

Remove the protective cover to replace the fuses.

Caution!

Removal of the protective cover and the replacement of the fuses must only be carried out by qualified skilled personnel when no voltage is applied.

Defective fuses must only be replaced by the prescribed type (see chapter 2.1 "Controller-specific data").

The protective cover must be attached again after the fuses are replaced.



5 Commissioning

Turn trimmers " n_{\min} ", " n_{\max} ", " V_p ", " $I \cdot R$ " fully counterclockwise.

Trimmers " $U_{\text{Leit grob}}$ " and " $U_{\text{Leit fein}}$ " are factory-set for the set-value potentiometer connection as a standard.

Only if a master voltage is used: " $U_{\text{Leit grob}}$ " must be turned fully counterclockwise and " $U_{\text{Leit fein}}$ " to a middle position for the subsequent base setting.

Trimmer " I_{\max} " is factory-set to rated controller current.

5.1 Setting the current limit

The current limit only needs to be set if the motor current is lower than the rated controller current.

Connect a moving coil meter in the armature circuit to measure the current. Block the armature or disconnect the field.

Caution:

Observe the current capacity of the motor at standstill!

Turn trimmer " n_{\min} " fully clockwise and connect the mains.

Turn trimmer " I_{\max} " to adjust the armature current.

Then turn trimmer " n_{\min} " fully counterclockwise.





5.2 Armature voltage control with "I x R compensation"

Caution!

In this operating mode all control terminals carry mains potential. It is therefore necessary that all input and output signals required for the control of the controller are safely separated electrically by measures outside the controller and have another protection against direct contact (double basic insulation).

When using the supplied set-value potentiometer, the mechanical screw fixing must have an additional PE connection and the connections must be insulated and covered.

- Connect motor terminal A to controller terminal 1 and motor terminal B to controller terminal 2 (see connecting diagram).
- Set set-value potentiometer or master voltage to zero.
Connect mains.
LED "RSP" is illuminated.
LED " $\pm V_{CC}$ " is illuminated.
- Set set-value potentiometer or master voltage to maximum.
In case of master voltage operation, turn trimmer " $U_{Leit\ grob}$ " clockwise until '+10 V=' are applied at measuring point "M1" (measured across terminal 3, terminal 7, or terminal 33 = GND).
- Close switch "RFR".
LED "RSP" is not illuminated.
- Turn trimmer " n_{max} " clockwise until the desired maximum speed is obtained.
- Set set-value potentiometer or master voltage to zero.
- Turning trimmer " n_{min} " clockwise increases the minimum speed.
Check the adjustment of the maximum speed since trimmers " n_{max} " and " n_{min} " influence each other.
The fine setting of the maximum speed, is done using trimmer " $U_{Leit\ fein}$ ".
- Turn trimmer " V_p " clockwise, until the drive becomes unstable (speed oscillations), then turn trimmer " V_p " approx. 20 % counterclockwise until the drive is stable again.
- Set the speed stabilization at trimmer "I x R" such that the smallest speed change results with the smallest operating speed between idle running and rated load. Then check the compensation for higher speeds.

5.3 Speed control with tacho feedback

Caution!

In this operating mode, the control electronics has a simple basic insulation. Take measures outside the controller to ensure that the input and output signals of the control have a double basic insulation.

- Set set-value potentiometer or master voltage to zero.
Connect mains.
LED "RSP" is illuminated.
LED " $\pm V_{CC}$ " is illuminated.
- Set set-value potentiometer or master voltage to maximum.
- In case of master voltage operation, turn trimmer " $U_{Leit\ gross}$ " clockwise until '+10 V=' are applied at measuring point "M1" (measured across terminal 3, terminal 7, or terminal 33 = GND).
- Close switch "RFR".
LED "RSP" is not illuminated.

Caution!

In case of uncontrolled acceleration of the motor during speed setting, immediately open switch "RFR". In this case, the tachogenerator feedback is either missing or has incorrect polarity.

After checking and correcting the wiring, commissioning can be started again.

- Turn trimmer " n_{max} " clockwise until the desired maximum speed is obtained.
- Set set-value potentiometer of master voltage to zero.
- Turning trimmer " n_{min} " clockwise increases the minimum speed. Check the adjustment of the maximum speed since trimmers " n_{max} " and " n_{min} " influence each other. The fine setting of the maximum speed is done using trimmer " $U_{Leit\ fein}$ ".
- Turn trimmer " V_p " clockwise, until the drive becomes unstable (speed oscillations), then turn trimmer " V_p " approx. 5 % counterclockwise until the drive is stable.

6 Switching operation

6.1 Controller enable

If switch "RFR" is closed, the controller is enabled.

If the switch "controller enable" (RFR) is open the speed controller is inhibited, i.e. the firing pulses are set to the inverter limit position.

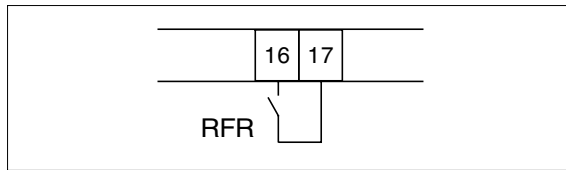

Only use low-current contacts for the switching of signal cables
(15V / 1.5mA)

6.2 Controller inhibit

The function "RSP", i.e. the inhibiting of the controller with a normally-open contact is possible using the following connection.

When "RSP" (controller inhibit) is closed, the firing pulses are set to the inverter limit position.

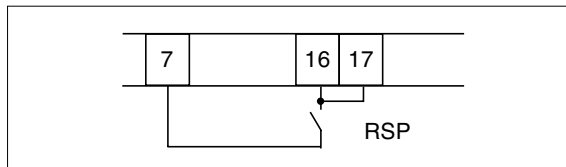

Only use low-current contacts for the switching of signal cables
(15V / 1.5mA)

Index

A

- Accessories 9
- Additional terminals 22
- Application
 - as directed 8

C

- Commissioning 23
 - Armature voltage control with "I · R compensation" 24
 - Setting the current limit 23
- Controller features 5
- Controller-specific data 6

D

- Dimensions 7
 - Mains choke** 10
 - RFI filter** 11, 12

I

- Installation 13
 - Connecting diagram 19
 - Connection 13
 - Installation 13

O

- Operating modes
 - Controller enable 26
 - Controller inhibit 26

R

- Replacing the fuses 22

S

- Scope of supply 8
- Special field voltages 20
- Speed control with tacho feedback 25

