

# ACCU ELECTRIC MOTORS INC

USA: (888) 932-9183

CANADA: (905) 829-2505

- ✓ Over 100 years cumulative experience
- ✓ 24 hour rush turnaround / technical support service
- ✓ Established in 1993



The leading independent repairer of servo motors and drives in North America.

Visit us on the web:

[www.servo-repair.com](http://www.servo-repair.com)

[www.servorepair.ca](http://www.servorepair.ca)

[www.ferrocontrol.com](http://www.ferrocontrol.com)

[www.sandvikrepair.com](http://www.sandvikrepair.com)

[www.accuelectric.com](http://www.accuelectric.com)

**Scroll down to view your document!**

For 24/7 repair services :

USA: 1 (888) 932 - 9183

Canada: 1 (905) 829 -2505

Emergency After hours: 1 (416) 624 0386

Servicing USA and Canada

# MOOG

**Fastact T/F**  
Brushless Servomotors  
*Servomotori Brushless*



Section	Page
Description	2
Standard Models	3
Technical Data	4
Options	25
Connections	27
Ordering Information	29

Sezione	Pag
Descrizione	2
Esecuzione Standard	3
Dati Tecnici	4
Opzioni	25
Connessioni	27
Per Ordinare	29



This catalog is for users with technical knowledge. To ensure that all necessary characteristics for function and safety of the system are given, the user has to check the suitability of the products described herein.

The products described herein are subject to change without notice. In case of doubt, please contact Moog.

Questo catalogo è riservato a utenti con competenze tecniche. Si consiglia di verificare che le caratteristiche del prodotto siano idonee a garantire il sicuro e corretto funzionamento del sistema.

I dati indicati in questo catalogo possono essere modificati senza preavviso. Per ulteriori informazioni, si prega contattare Moog.

Moog is a registered trademark of Moog Inc. and its subsidiaries.

All trademarks as indicated herein are the property of Moog Inc. and its subsidiaries.

©Moog Inc. 2003. All rights reserved. All changes are reserved.

For the most current information, visit [www.moog.com/servomotorsanddrives](http://www.moog.com/servomotorsanddrives)

Dimensions and tolerances in mm  
Dimensioni meccaniche in mm

Series T FASTACT servomotors are the solution to the ever increasing demands of accurate axis control in industrial automation applications. FAST T servomotors provide high dynamic performance characteristics coupled with automated production techniques, to offer the customer established brushless motor performance advantages and traditional dc servo system economy.

The FAS F family is the FAS T version equipped with an integral fan for forced cooling of the motor casing allowing better performances with limited weight and size increase.

The wider range of choice consists of six frame sizes and is composed of 41 types.

Torque ratings range from 0.3 to 430 Nm at  $\Delta\theta$  win = 65°C (0.4 to 522 Nm at  $\Delta\theta$  win = 110°C) and there are two speed ratings for each type.

FAS T/F servomotors are available in "M" and "V" versions. Type "M" windings are designed for use with 230 Vac drives; namely our DS2000 and  $\mu$ DS digital servodrives.

Type "V" windings are designed for use with our range of 400/460 Vac digital drives: DBM04 (multi-axis), DBS, DS2000 and  $\mu$ DS (single-axis).

For heavy duty applications, we recommend the use of their FAS F range.

The recommended digital drives/motors systems are listed in the Technical data; for the analog drives BRM and BRD please contact our appointed Service Centers.

Compliance is guaranteed to EN 61800-3 (1996) for industrial environment, according to 89/336/EC Directive (EMC).

*I servomotori FASTACT serie T sono il risultato dell'attenzione da noi prestata all'evoluzione delle necessità dell'automazione industriale nel controllo assi. I FAS T, infatti, conservano le caratteristiche di elevata dinamica e prestazioni delle serie precedenti, offrendo agli utilizzatori tutti i vantaggi intrinseci dei servomotori brushless a condizioni economiche direttamente alternative ai tradizionali servosistemi in corrente continua; i FAS F, sono la versione FAS T con raffreddamento ad aria forzata che permette un ulteriore incremento di prestazioni contenendo peso e dimensioni.*

*La gamma di scelta risulta quindi ampliata ed è ora articolata in sei taglie, composta da 41 tipi, con coppia nominale da 0,3 a 430 Nm con  $\Delta\theta$  avv = 65°C (da 0.4 a 522 Nm con  $\Delta\theta$  avv = 110°C); per ogni tipo sono previste due velocità standard.*

*I servomotori FAS T e F sono disponibili in versione 230 Vac e 400/460 Vac. Nella versione con avvolgimento tipo "M" sono compatibili con gli azionamenti a 230 Vac, ovvero con gli azionamenti digitali DS2000 e  $\mu$ DS.*

*Nella versione con avvolgimento tipo "V" sono compatibili con gli azionamenti ad alimentazione diretta da rete (400/460 Vac), ovvero con gli azionamenti digitali monoasse DBS, DS2000 e  $\mu$ DS, multiasse DBM04.*

*Gli accoppiamenti suggeriti con gli azionamenti digitali sono riportati nelle tabelle. Gli accoppiamenti con azionamenti analogici (es. BRM, BRD) possono essere definiti con la nostra rete vendite.*

*I servomotori FAS T e F, insieme ai nostri azionamenti, sono conformi alla norma CEI EN 61800-3 (1996) per ambiente industriale, secondo la Direttiva 89/336/CEE (EMC).*

- rare earth magnets
  - 3-phase star connected winding
  - nominal voltage at nominal torque and nominal speed: 180V for M version and 325V for V version
  - IP64 protection, according to IEC 60034-5 (2000), except forced ventilation system for FAS F
  - class F insulation
  - ambient temperature:  $-25^{\circ}\div +40^{\circ}\text{C}$
  - altitude not exceeding 1000 meters at sea level
  - storage temperature:  $-25^{\circ}\div +70^{\circ}\text{C}$
  - IC 00 41 cooling (totally enclosed, not ventilated) according to EN60034-6 (1995) for FAS T, by forced axial fan ventilation for FAS F (power supply 220 Vac single-phase for F1 and F2, 220 Vac 3-phase for F3 and F4)
  - resolver poles number:  
FAS T00 and 0, FAS T/F 1, 2 and 3: 6 pole motor, 6 pole resolver  
FAS T/F 4: 8 pole motor, 8 pole resolver; when  $\omega > 8000$  rpm for DBM04, DBS, DS2000 and  $\mu\text{DS}$  drives: 2 pole resolver
  - B14 flange mounting for size 0, B5 for size 00, 1, 2, 3, and 4
  - shielded bearings lubricated for life
  - construction and mounting arrangement for size 0 is IM B14, IM V18 and IM V19; for size 00, 1, 2, 3 and 4 IM B5, IM V1 and IM V3 according to EN60034-7 (1993)
  - shock:  $30 g_N$  per 11 ms, on two axes according to IEC 68-2-27 (1987)
  - vibrations: 0,3 mm peak-to-peak up to 57 Hz,  $2 g_N$  from 57 Hz to 150 Hz, on two axes, according to IEC 68-2-6 (1995)
  - cylindrical shaft with metric screwthread hole for mechanical interface mounting, according to DIN 332 (1983)
  - dynamic balancing accuracy  $Q = 2,5$  according to ISO 1940-1 (note: balancing with key, if applicable)
  - black finish
  - thermal protection using PTC with threshold at  $130^{\circ}\text{C}$  for M version and  $155^{\circ}\text{C}$  for V version
  - PT bayonet signal connector (\*) and terminal board for power connection
  - plug connectors (\*) included
  - $90^{\circ}$  indexable connector box (\*)
  - MTBF at  $20^{\circ}\text{C}$ ,  $\Delta\theta_{win} = 65^{\circ}\text{C}$ , ground fixed motor: 200,000 hours
- (\*) power and resolver connection leads for T00.
- magneti a terre rare
  - avvolgimento trifase a stella
  - tensione nominale a coppia e velocità nominali: 180 V per la versione M e 325 V per la versione V
  - protezione IP64, secondo IEC 60034-5 (2000), escluso gruppo di ventilazione forzata sui FAS F
  - isolamento Classe F
  - temperatura ambiente:  $-25^{\circ}\div +40^{\circ}\text{C}$
  - altitudine non superiore a 1000 m s.l.m.
  - temperatura magazzinaggio:  $-25^{\circ}\div +70^{\circ}\text{C}$
  - raffreddamento IC 00 41 (macchina chiusa non ventilata) secondo CEI EN60034-6 (1995) per FAS T, con ventilazione forzata con ventilatore assiale per FAS F (alimentazione 220 Vac monofase per F1 e F2, 220 Vac trifase per F3 e F4)
  - numero poli resolver:  
FAS T00 e 0, FAS TIF 1, 2, 3 : motore 6 poli, resolver 6 poli  
FAS TIF4 : motore 8 poli, resolver 8 poli ;  
quando  $w > 8000$  r/min per DBM04, DBS, DS2000 e  $\mu\text{DS}$ : resolver 2 poli
  - flangia B14 per taglia 0 e B5 per taglie 00, 1, 2, 3 e 4
  - cuscinetti schermati lubrificati a vita
  - forma costruttiva e predisposizione montaggio IM B14, IM V18 e IM V19 per taglia 0; IM B5, IM V1 e IM V3 per taglie 00, 1, 2, 3 e 4 secondo EN60034-7 (1993)
  - urti:  $30 g_N$  per 11 ms, sui due assi, secondo IEC 68-2-27 (1987)
  - vibrazioni: 0,3 mm picco-picco fino a 57 Hz,  $2 g_N$  da 57 Hz a 150 Hz, sui due assi, secondo IEC 68-2-6 (1995)
  - albero liscio con foro filettato per calettamento secondo DIN 332 (1983)
  - grado di equilibratura  $Q = 2,5$  secondo ISO 1940-1 (nota: equilibratura con chiavetta per opzione chiavetta)
  - colore nero
  - protezione termica tramite PTC con soglia a  $130^{\circ}\text{C}$  per la versione M e  $155^{\circ}\text{C}$  per la versione V
  - connettore (\*) tipo PT a baionetta per i segnali e morsettiera per la potenza
  - parte volante connettore (\*) a corredo
  - scatola connettore (\*) ruotabile di  $90^{\circ}$
  - MTBF a  $20^{\circ}\text{C}$ ,  $\Delta\theta_{avv} = 65^{\circ}\text{C}$ , motore fisso al suolo: 200.000 ore
- (\*) cavi volanti per T00.

**TORQUE/SPEED CHARACTERISTICS / CARATTERISTICA COPPIA/VELOCITÀ**

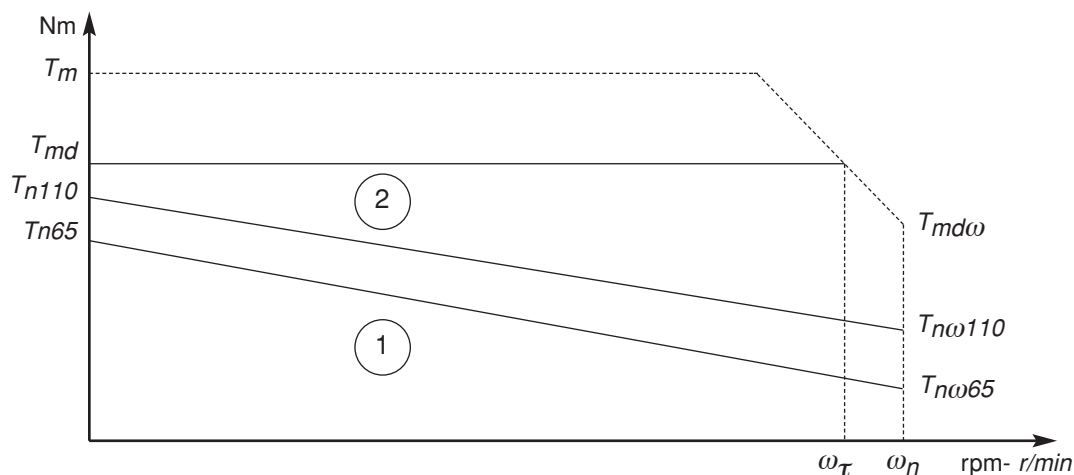

Tn65 : nominal torque, continuous duty, locked rotor  
 $\Delta\theta_{win} = 65^{\circ}\text{C}$

Tn110 : nominal torque, continuous duty, locked rotor  
 $\Delta\theta_{win} = 110^{\circ}\text{C}$

Tn $\omega$ 65 : nominal torque, continuous duty, nominal speed  
 $\Delta\theta_{win} = 65^{\circ}\text{C}$

Tn $\omega$ 110 : nominal torque, continuous duty, nominal speed  
 $\Delta\theta_{win} = 110^{\circ}\text{C}$

Tm : peak torque

Tmd : max torque with recommended drive

Tmd $\omega$  : max torque at nominal speed with recommended drive

$\omega_n$  : nominal speed

$\omega_{\tau}$  : cutoff speed at max torque with recommended drive

Area 1: continuous duty zone

Area 2: intermittent duty zone; the performances at a specified duty rate are available under request.

Tn65 : coppia in servizio continuo, rotore bloccato con  
 $\Delta\theta_{avv} = 65^{\circ}\text{C}$

Tn110 : coppia in servizio continuo, rotore bloccato con  
 $\Delta\theta_{avv} = 110^{\circ}\text{C}$

Tn $\omega$ 65 : coppia in servizio continuo, alla velocità nominale con  
 $\Delta\theta_{avv} = 65^{\circ}\text{C}$

Tn $\omega$ 110 : coppia in servizio continuo, alla velocità nominale con  
 $\Delta\theta_{avv} = 110^{\circ}\text{C}$

Tm : coppia massima erogabile dal motore

Tmd : coppia massima con azionamento consigliato

Tmd $\omega$  : coppia massima con azionamento consigliato alla velocità nominale

$\omega_n$  : velocità nominale

$\omega_{\tau}$  : velocità massima alla Tmd

Area 1: zona di servizio continuo

Area 2: zona di servizio intermittente; su richiesta sono disponibili le prestazioni del sistema in funzione del grado di intermittenza.

**RECOMMENDED DRIVE**

The recommended drive showed in the following "Technical Data" is able to give the best mix of performances in terms of max torque (Tmd) and drive type. If the performances required by the customer application consent the use of different drive a new coupling drive-motor is possible; for the evaluation of the max torque Tmd1 with the new drive it is possible the use of the following formula:

$$Tmd1 = Tmd * (Imax \text{ new drive} / Imax \text{ recommended drive})$$

**AZIONAMENTO CONSIGLIATO**

L'azionamento consigliato nelle tabelle "Dati Tecnici" è quello che offre il miglior compromesso di prestazioni in termini di coppia massima (Tmd) e tipo dell'azionamento. Se le prestazioni richieste al sistema lo consentono è possibile accoppiare al motore un azionamento diverso da quello indicato; orientativamente la coppia massima Tmd1 ottenuta con il nuovo accoppiamento motore-azionamento si può calcolare come segue:

$$Tmd1 = Tmd * (Imax \text{ drive nuovo} / Imax \text{ drive consigliato})$$

## DIMENSIONS AND TOLERANCES / DIMENSIONI E TOLLERANZE

(See page 27 for the connection box dimensions / Dimensioni scatola connessioni a pag.27)

### FAS T00

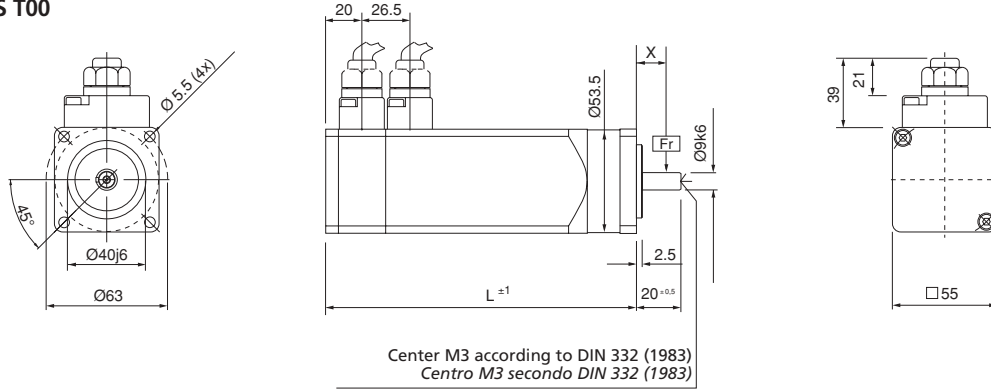

Standard Motors Motori Standard	L
2 modules/moduli	135
4 modules/moduli	165

### FAS T0

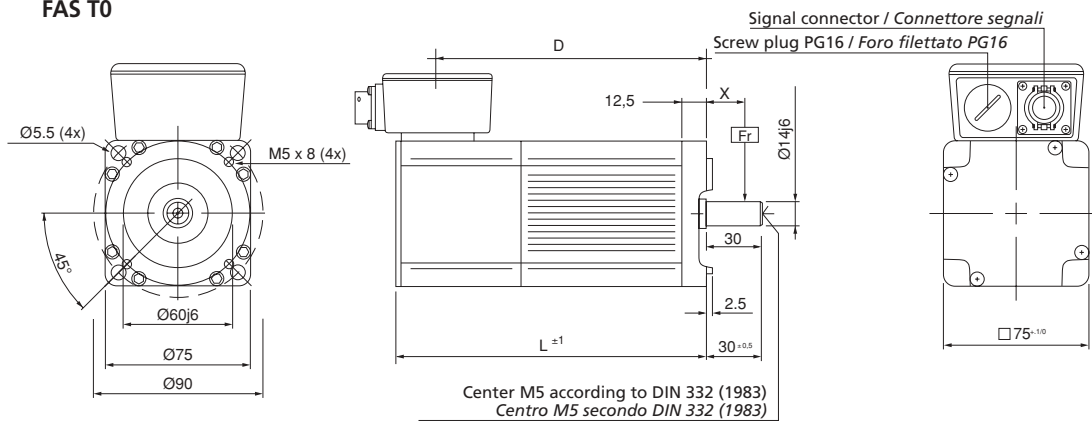

Standard Motors Motori Standard	L	D
2 modules/moduli	148	111
4 modules/moduli	169	132
8 modules/moduli	211	174

### FAS T1

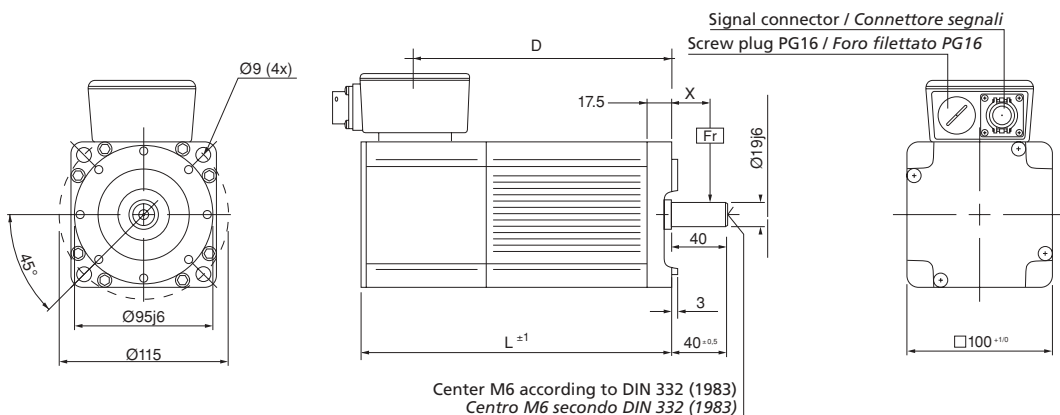

Standard Motors Motori Standard	L	D
2 modules/moduli	173	137
4 modules/moduli	217	181
6 modules/moduli	261	225
8 modules/moduli	305	269

## DIMENSIONS AND TOLERANCES / DIMENSIONI E TOLLERANZE

(See page 27 for the connection box dimensions / Dimensioni scatola connessioni a pag.27)

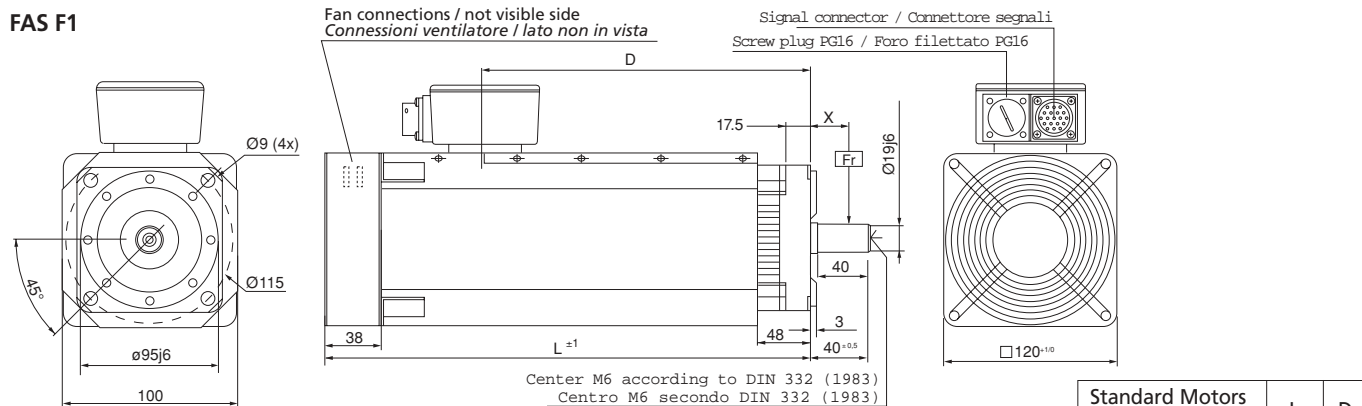

Standard Motors Motori Standard	L	D
2 modules/moduli	242	137
4 modules/moduli	291	181
6 modules/moduli	335	225
8 modules/moduli	379	269

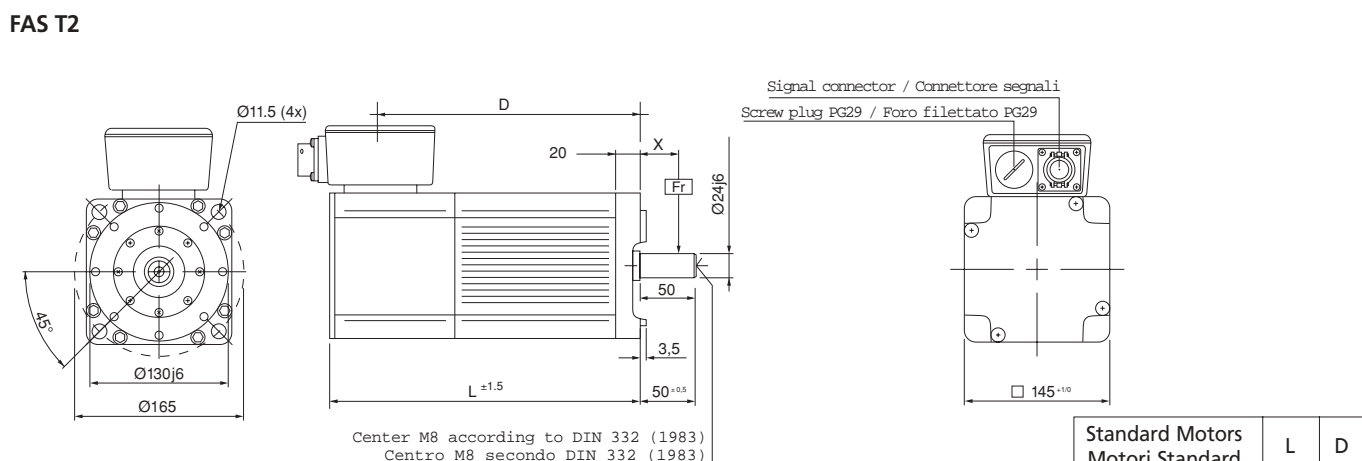

Note: FAS T2 M8/V8 has two eyebolts.  
Nota: sul motore FAS T2 M8/V8 sono montati 2 golfari.

Standard Motors Motori Standard	L	D
2 modules/moduli	220	172
4 modules/moduli	274	226
6 modules/moduli	328	280
8 modules/moduli	382	334

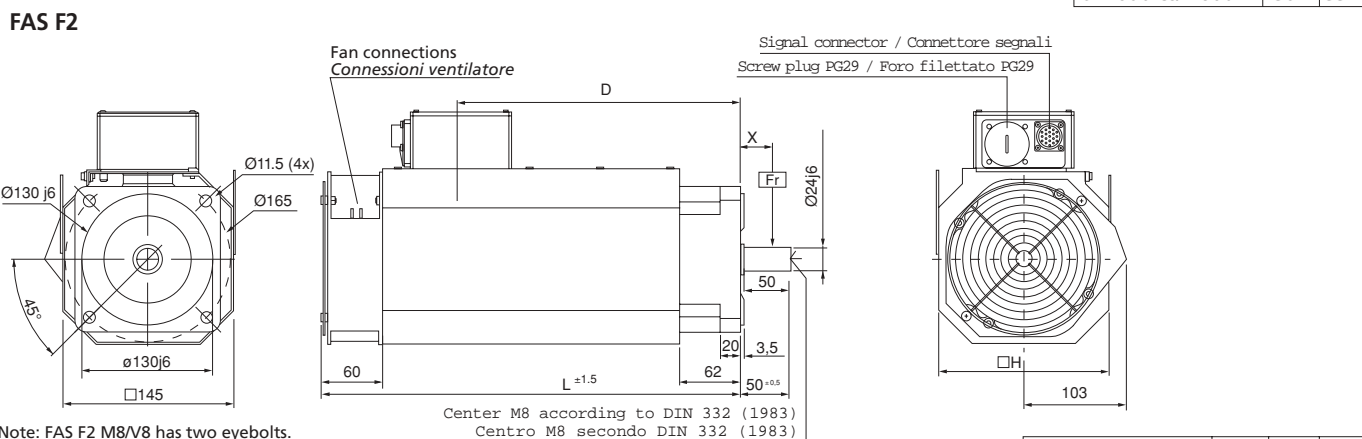

Note: FAS F2 M8/V8 has two eyebolts.  
Nota: sul motore FAS F2 M8/V8 sono montati 2 golfari.

Standard Motors Motori Standard	L	D	H
2 modules/moduli	309	172	169
4 modules/moduli	363	226	169
6 modules/moduli	417	280	187
8 modules/moduli	471	334	187

## DIMENSIONS AND TOLERANCES / DIMENSIONI E TOLLERANZE

(See page 27 for the connection box dimensions / Dimensioni scatola connessioni a pag.27)

### FAS T3

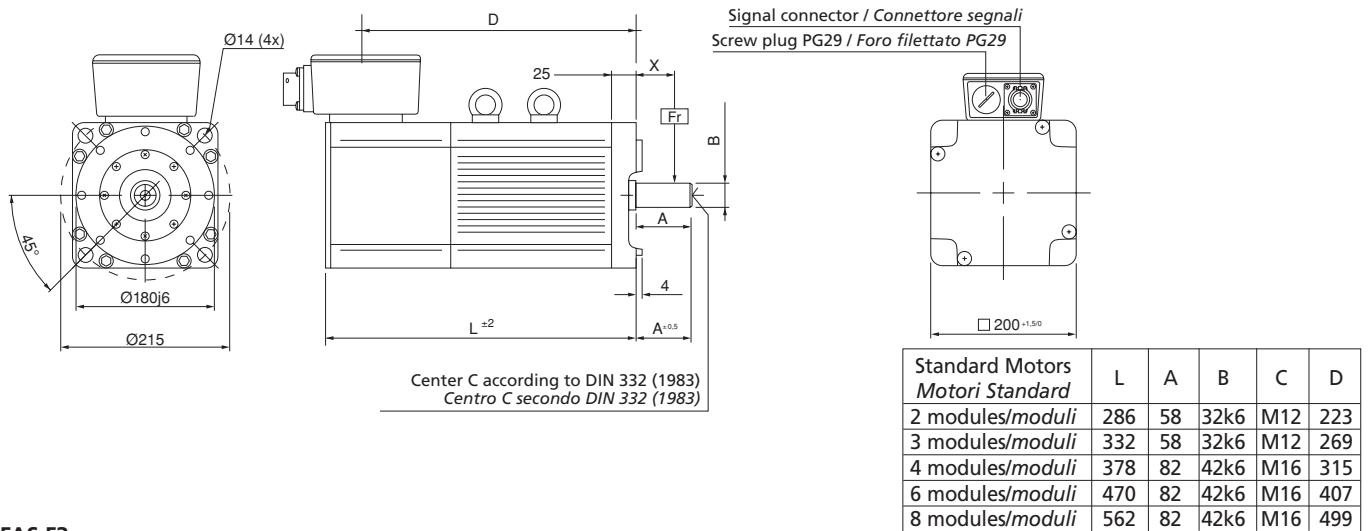

### FAS F3

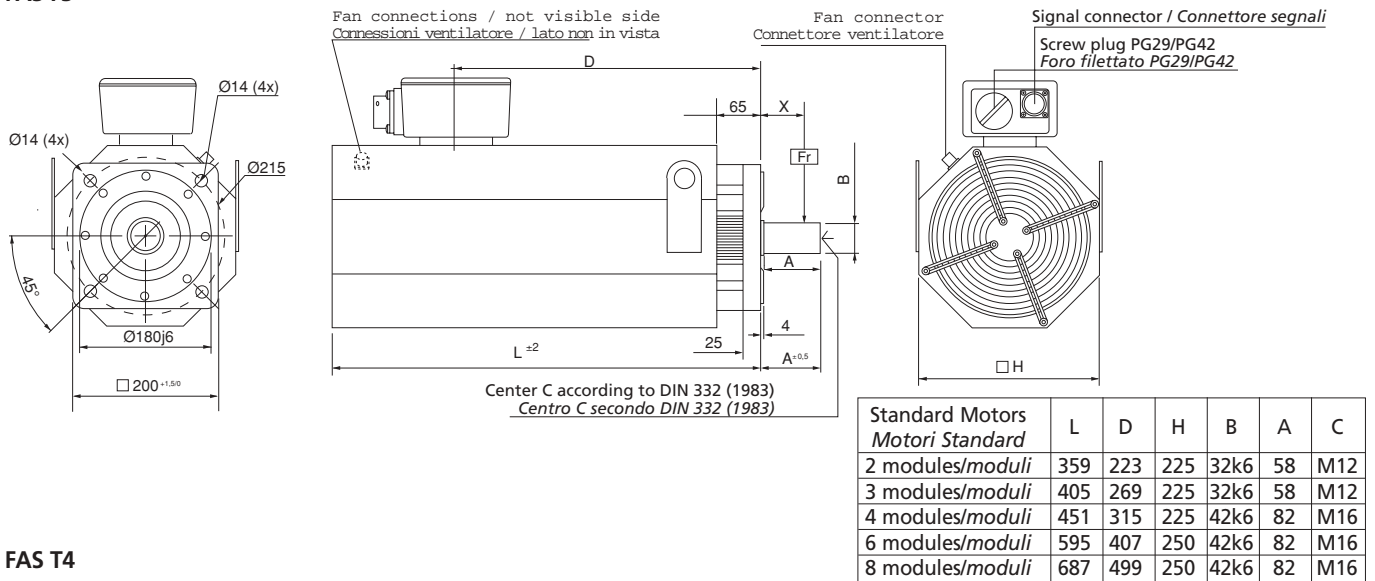

### FAS T4

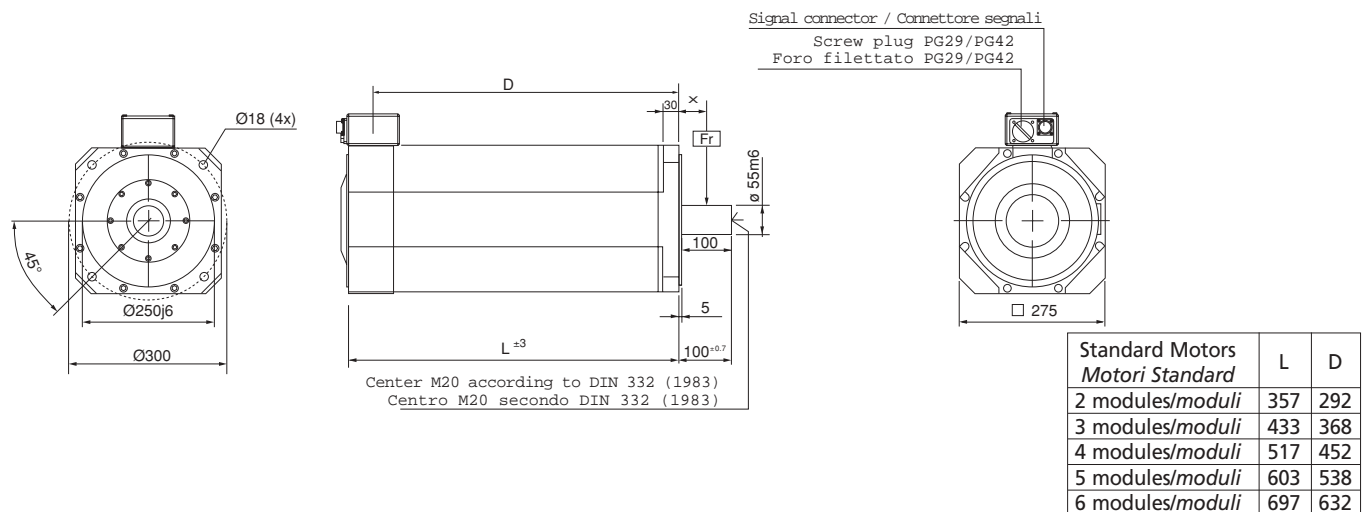



**DIMENSIONS AND TOLERANCES / DIMENSIONI E TOLLERANZE**

(See page 27 for the connection box dimensions / *Dimensioni scatola connessioni a pag.27*)

**FAS F4**

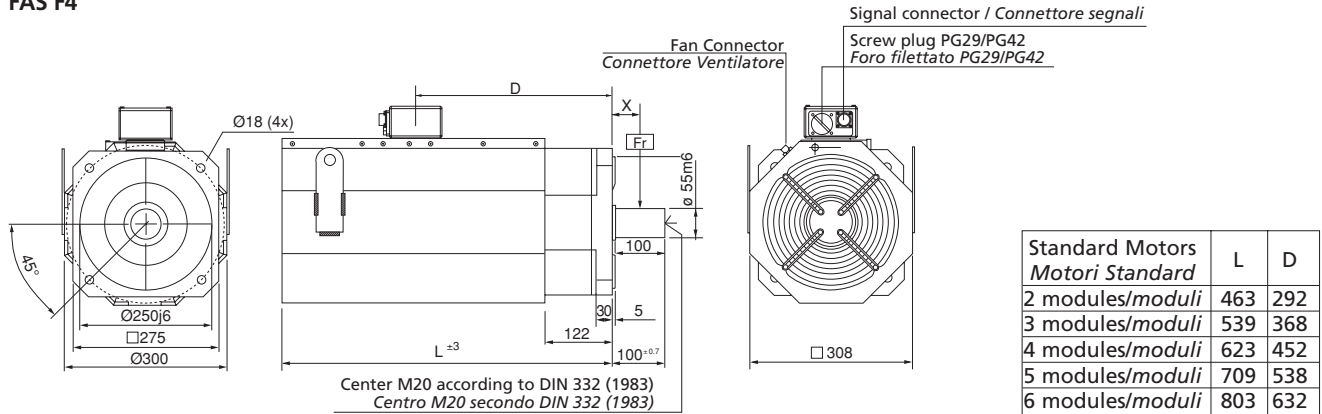

**RECOMMENDED WIRING**

- Signal Cable: Recommended 4 pair, each pair twisted and individually shielded AWG22 (0.38 mm<sup>2</sup>) with an independent overall shield. Cable length should not exceed 30 m. It is recommended that the signal cable, power cable and brake cable be separated by a distance of 30 cm.
- Power cable: four conductors, shielded, recommended section for single wire, as in technical data table.
- Brake cable: One pair 20 AWG (0.60 mm<sup>2</sup>) min. wire, shielded.
- Fan cable: FAS F1 and F2, 3-conductor cable 0.60 mm<sup>2</sup> section, (AWG20); FAS F3 and F4, 4-conductor cable 1.5 mm<sup>2</sup> section (AWG16).

**CABLAGGIO CONSIGLIATO**

- Cavo collegamento segnali: cavetto multipolare a bassa capacità con conduttori AWG 22 (0.38 mm<sup>2</sup>) gemellati a coppie, intrecciati e schermati con ulteriore schermatura con calza esterna. La lunghezza del cavo non deve superare 30 m. Il cavo deve essere separato dal cavo collegamento potenza e cavo collegamento freno di almeno 30 cm.
- Cavo collegamento potenza: quadripolare schermato, sezione consigliata, per singolo conduttore, in tabella dati tecnici.
- Cavo colleg. freno: bipolare schermato 0.6 mm<sup>2</sup> min. (20 AWG)
- Cavo collegamento ventilatore: motori FASF1, F2: cavetto tripolare sezione 0.60 mm<sup>2</sup> (AWG20); motori FAS F3, F4 cavo quadripolare sezione 1.5 mm<sup>2</sup> (AWG16)

**EMC**

To meet the EC Directive 89/336/EEC (EMC), and for the proper system operation, signal and power cables must be screened / shielded (85% minimum coverage). The shield must be earthed at both sides with Radio Frequency type connection (i.e. 360°). The motor connections must be made as follows: Connector: Via connector clamp; Terminal board: Via a metallic PG gland.

**EMC**

Per la conformità alla Direttiva 89/336/CE (EMC) e per il corretto funzionamento del sistema, i cavi di segnale e potenza devono essere schermati (copertura minima 85%). Lo schermo deve essere collegato al telaio a entrambe le estremità con connessione a radio frequenza (ovvero 360°). La connessione lato motore deve essere effettuata come segue: connettore: tramite il serracavo del connettore; morsettiera: tramite pressacavo metallico

**RADIAL LOADS**

Maximum radial load on motor shaft vs. distance from flange and motor shaft speed referred to ball bearing rating life = 20000 h. (reliability of 90%,  $\Delta\theta_{win} = 65^\circ\text{C}$ ).

Note: maximum axial load must not exceed 30% of maximum radial load.

**Caution!** Avoid axial shock on shaft during assembling.

**CARICHI RADIALI**

Carico radiale ammissibile sull'albero in funzione della distanza del punto di applicazione dalla flangia e della velocità riferito ad una vita dei cuscinetti di 20000 ore (durata di base con affidabilità del 90%,  $\Delta\theta_{avv} = 65^\circ\text{C}$ ).

Nota: il massimo carico assiale non può eccedere il 30% del massimo carico radiale ammesso.

**Attenzione!** Evitare shock assiali sull'albero durante il montaggio.

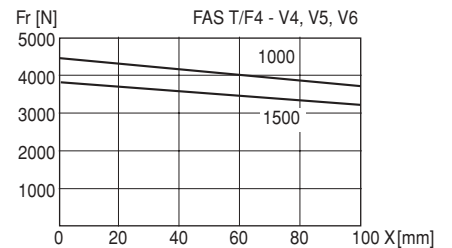
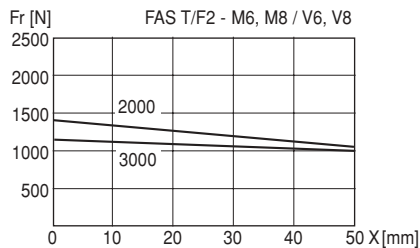
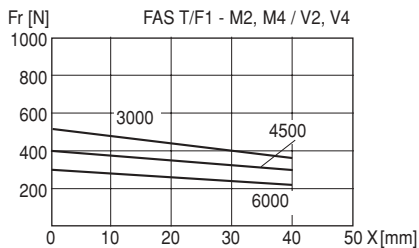
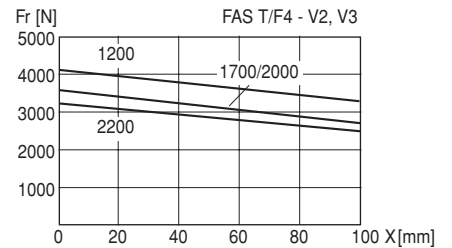
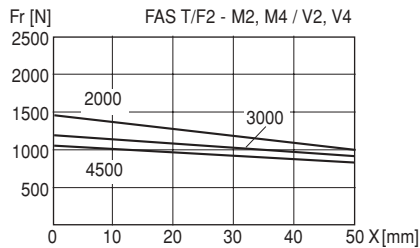
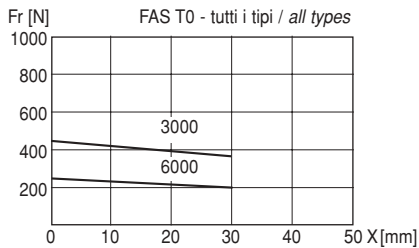
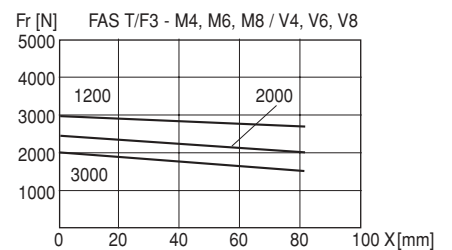
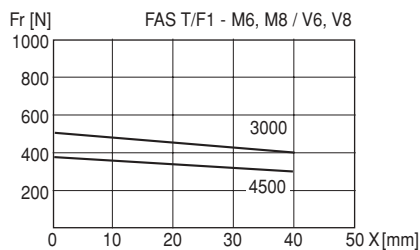
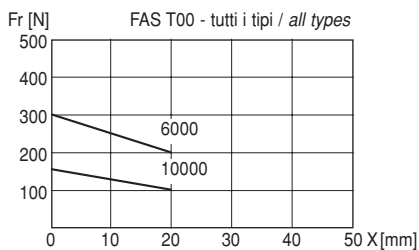

Note:  
see motor drawings for X[mm] dimension.  
Rotational speed in rpm

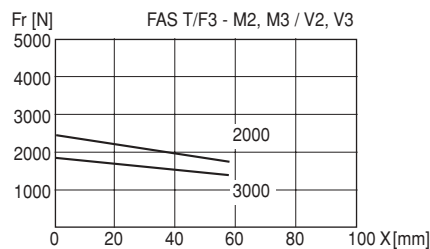

Note:  
vedere disegni motori per quota X[mm].  
Velocità di rotazione espressa in r/min

**PERFORMANCE SPECIFICATIONS / DATI RENDIMENTO**

Characteristics and nominal values with sinusoidal drive <i>Caratteristiche e valori nominali con azionamento sinusoidale</i>	Motor Size <i>Taglia Motore</i>	FAS T00			
		M2 060	M2 100	M4 060	M4 100
		V	V2 100	V	V4 100
Number of rotor modules / <i>Numero dei moduli rotore</i>		2	2	4	4
Nominal torque, continuous duty, locked rotor $\Delta\theta$ win=65°C° <i>Coppia nominale in servizio continuo, rotore bloccato con <math>\Delta\theta</math> avv=65°C°</i>		0.3	0.3	0.56	0.56
Torque, continuous duty, locked rotor $\Delta\theta$ win=110°C° <i>Coppia in servizio continuo, rotore bloccato con <math>\Delta\theta</math> avv=110°C°</i>		0.4	0.4	0.74	0.74
Peak Torque / <i>Coppia di picco</i>		1.6	1.6	3	3
Recommended drive <i>Azionamento consigliato</i>	DS2000 (μDS) 230 Vac M	3/6* (3/8*)	3/6 (3/8*)	3/6 (3/8)	6/11 (6/16*)
	DBS/DBM04 V	-	3/6*	-	3/6
Max torque with recommended drive <i>Coppia max con azionamento consigliato</i>	DS2000 (μDS) 230 Vac M	1.6 (1.6)	1.5 (1.6)	2.4 (3)	2.4 (3)
	DBS/DBM04 V	-	1.5	-	2.9
Nominal speed / <i>Velocità nominale</i>	DS2000 (μDS) 400 Vac V	-	3/6* (3/8*)	-	3/6 (3/8*)
	DS2000 (μDS) 400 Vac V	-	3/6* (3/8*)	-	3/6 (3/8*)
Nominal torque, continuous duty, nominal speed ( $\Delta\theta$ win = 65°C°) <i>Coppia nominale in servizio continuo, velocità nom (<math>\Delta\theta</math> avv = 65°C°)</i>		0.2	0.1	0.33	0.2
Nominal torque, continuous duty, nominal speed ( $\Delta\theta$ win = 110°C°) <i>Coppia nominale in servizio continuo, velocità nom (<math>\Delta\theta</math> avv = 110°C°)</i>		0.3	0.25	0.55	0.45
Max torque at nom.speed with recom.drive <i>Coppia max con azionamento consigliato alla velocità nominale</i>	DS2000 (μDS) 230 Vac M	1.2 (1.2)	1.3 (1.3)	2.15 (2.15)	2.3 (2.3)
	DBS/DBM04 V	-	1.5	-	1.8
Cutoff speed at max torque with recom. drive•• <i>Velocità di taglio alla coppia max con azionamento consigliato••</i>	DS2000 (μDS) 230 Vac M	3100 (3100)	6200 (6000)	3950 (3500)	8000 (7500)
	DBS/DBM04 V	-	10000	-	6000
Output power, continuous duty, nominal speed ( $\Delta\theta$ win = 65°C°) <i>Potenza resa in servizio continuo alla velocità nom. (<math>\Delta\theta</math> avv = 65°C°)</i>	DS2000 (μDS) 400 Vac V	-	1.5 (1.5)	-	2.4 (2.4)
	DS2000 (μDS) 400 Vac V	-	10000 (10000)	-	7000 (7000)
Output power, continuous duty, nominal speed ( $\Delta\theta$ win = 110°C°) <i>Potenza resa in servizio continuo alla velocità nom. (<math>\Delta\theta</math> avv = 110°C°)</i>		0.12	0.105	0.21	0.21
Rotor inertia (resolver included) <i>Momento d'inerzia rotorico (con resolver)</i>		17.3	17.3	26.3	26.3
Mechanical time constant <i>Costante di tempo meccanica</i>	M	3.98	3.69	2.16	2.23
	V	-	5.22	-	2.84
Weight / <i>Massa</i>		1.26	1.26	1.65	1.65
Thermal time constant / <i>Costante di tempo termica</i>		490	490	500	500
Torque constant <i>Costante di coppia</i>	M	0.36	0.24	0.39	0.23
	V	-	0.29	-	0.46
Electrical time constant <i>Costante di tempo elettrica</i>	M	0.71	0.76	1.04	1.00
	V	-	0.77	-	1.10
Winding resistance at 20°C (phase to phase) <i>Resistenza a 20°C tra le fasi</i>	M	17.2	7.1	7.2	2.34
	V	-	14.64	-	10.36
Winding inductance (phase to phase) <i>Induttanza tra le fasi</i>	M	13.3	5.2	7.4	2.56
	V	-	9.0	-	9.85
Nominal current, locked rotor ( $\Delta\theta$ win = 65°C) <i>Corrente nominale a rotore bloccato (<math>\Delta\theta</math> avv = 65°C)</i>	M	0.85	1.27	1.4	2.4
	V	-	1.04	-	1.2
Power terminal board (see page 27) <i>Morsettiera potenza (vedere p. 27)</i>	M	-	-	-	-
	V	-	-	-	-
Power connector (see page 27) <i>Connettore potenza (vedere p. 27)</i>	M	-	-	-	-
	V	-	-	-	-
Recommended power cable square section (4x) <i>Sezione cavo consigliata (4x)</i>	M	0.75 (18)	0.75 (18)	0.75 (18)	0.75 (18)
	V	-	0.75 (18)	-	0.75 (18)

M / V / • / •• / ••• / \* / ■ / ▼ see general remarks on page 24 / vedere note generali a pag. 24

FAS T0						Symbol Simbolo	Unit Unità
M2 030	M2 060 V2 060	M4 030	M4 060 V4 060	M8 030	M8 060 V8 060	nr / n	
2	2	4	4	8	8	$T_{n65}$	Nm
0.5	0.5	1	1	1.9	1.9	$T_{n110}$	Nm
0.6	0.6	1.25	1.25	2.3	2.3	$T_m$	Nm
2.6	2.6	5.5	5.5	9	9	Drive Type Tipo azionamento	
3/6*(3/8*)	3/6 (3/8*)	3/6 (3/8*)	6/11 (3/8)	6/11 (3/8)	8/16 (6/16)	$T_{md}$	Nm
-	3/6	-	3/6	-	6/11	$\omega n$	rpm - r/min
-	3/6* (3/8*)	-	3/6 (3/8)	-	6/11 (6/16*)	$Tn\omega$	Nm
2.6 (2.6)	2.4 (2.6)	4.5 (5.5)	4.4 (3.2)	8.5 (6.3)	6.4 (6.4)	$Tn\omega$	Nm
-	2.6	-	4.1	-	6.6	$T_{md}\omega$	Nm
-	2.6 (2.6)	-	4.1 (5)	-	6.6 (9)	$\omega\tau$	rpm - r/min
3000	6000	3000	6000	3000	6000	$P_{out}$	kW
0.47	0.43	0.987	0.95	1.85	1.56	$P_{out}$	kW
0.58	0.55	1.2	1.1	2.2	2	$J$	10 <sup>6</sup> kgm <sup>2</sup>
0.9 (0.9)	0.95 (0.95)	1.8 (1.8)	2.3 (2.3)	3.9 (3.9)	4.6 (4.6)	$\tau m$	ms
-	1.6	-	2.6	-	5.7	$m$	kg
-	1.9 (1.9)	-	3.1 (3.1)	-	6.4 (6.4)	$\tau th$	s
100 (100)	1450 (1400)	600 (500)	2200 (2900)	850 (1300)	2800 (2800)	$K_t$	Nm/A
-	2000	-	2000	-	3500	$\tau_e$	ms
-	2500 (2500)	-	2400 (2300)	-	4000 (3200)	$R_w$	$\Omega$
0.15	0.27	0.31	0.60	0.58	0.98	$L_w$	mH
0.18	0.34	0.37	0.7	0.69	1.26	$I_n$	A
58	58	78	78	118	118	Type / Tipo	
10.71	10.70	4.93	4.37	2.61	3.02	Type / Tipo	
-	9.50	-	4.00	-	2.38	mm <sup>2</sup> (AWG)	
2.3	2.3	2.8	2.8	3.7	3.7		
710	710	790	790	1000	1000		
0.62	0.39	0.74	0.42	0.82	0.43		
-	0.44	-	0.65	-	0.64		
1.63	1.67	2.3	2.28	2.87	2.47		
-	1.89	-	2.51	-	3.13		
41	16.2	20	5.7	8.6	2.73		
-	18.3	-	12.9	-	4.9		
67	27.1	46	13	24.64	6.85		
-	34.5	-	31.4	-	14.9		
0.8	1.3	1.4	2.4	2.3	4.4		
-	1.1	-	1.5	-	3		
A	A	A	A	A	A		
-	A	-	A	-	A		
A	A	A	A	A	A		
-	A	-	A	-	A		
1.0 (18)	1.0 (18)	1.0 (18)	1.0 (18)	1.0 (18)	1.0 (18)		
-	1.0 (18)	-	1.0 (18)	-	1.0 (18)		

**PERFORMANCE SPECIFICATIONS / DATI RENDIMENTO**

Characteristics and nominal values with sinusoidal drive <i>Caratteristiche e valori nominali con azionamento sinusoidale</i>	Motor Size <i>Taglia Motore</i>	FAS T1							
		M2 030	M2 060	M4 030	M4 045	M6 030	M6 045	M8 030	M8 045
		V2 030	V2 060	V4 030	V4 045	V6 030	V6 045	V8 030	V8 045
Number of rotor modules / <i>Numero dei moduli rotore</i>		2	2	4	4	6	6	8	8
Torque, continuous duty, locked rotor $\Delta\theta$ win=65°C° <i>Coppia in servizio continuo, rotore bloccato con <math>\Delta\theta</math> avv=65°C°</i>		2.1	2.1	3.9	3.9	5.9	5.9	7.4	7.4
Torque, continuous duty, locked rotor $\Delta\theta$ win=110°C° <i>Coppia in servizio continuo, rotore bloccato con <math>\Delta\theta</math> avv=110°C°</i>		2.7	2.7	4.8	4.8	7.2	7.2	9.1	9.1
Peak torque / <i>Coppia di picco</i>		10	10	18	18	24	24	30	30
Recommended drive <i>Azionamento consigliato</i>	DS2000 (μDS) 230 Vac M	6/11(3/8)	8/16(6/16)	8/16(6/16)	14/30	14/30	14/30	14/30	14/30
	DBS / DBM04 V	3/6	6/11	6/11	8/16	8/16	15/30	8/16	15/30*
Max torque with recommended drive <i>Coppia max con azionamento consigliato</i>	DS2000 (μDS) 400 Vac V	3/6 (3/8)	6/11 (6/16)	6/11 (6/16)	8/16 (6/16)	8/16 (6/16)	14/30	8/16 (6/16)	14/30*
	DS2000 (μDS) 230 Vac M	8.1(6)	6.3(6.3)	12.5(12.5)	16	24	15.5	24	17
Nominal speed / <i>Velocità nominale</i>	DBS / DBM04 V	8	6.8	12.4	14	21.5	24	23	28
	DS2000 (μDS) 400 Vac V	8 (9.5)	6.8 (9.5)	12.4 (18)	14 (14)	21.5(21.5)	24	23 (23)	28
Nominal torque, continuous duty, nominal speed ( $\Delta\theta$ win = 65°C°) M <i>Coppia nom. in servizio continuo, velocità nom (<math>\Delta\theta</math> avv = 65°C°) V</i>		1.7	1.2	3.1	2.4	4.1	3	5.1	3.5
Nominal torque, continuous duty, nominal speed ( $\Delta\theta$ win = 110°C°) M <i>Coppia nom. in servizio continuo, velocità nom (<math>\Delta\theta</math> avv = 110°C°) V</i>		2.3	1.9	4.1	3.7	6.1	5.2	7.6	6.5
Max torque at nom.speed with recom.drive <i>Coppia max con azionamento consigliato alla velocità nominale</i>	DS2000 (μDS) 230 Vac M	5 (4.5)	5.4 (5.4)	10.5 (10.5)	12	18	15	21	16
	DBS / DBM04 V	5.2	5.5	11.5	11	16	17	20	24
Cutoff speed at max torque with recom. drive•• / <i>Velocità di taglio alla coppia max con azion. consigliato••</i>	DS2000 (μDS) 400 Vac V	6.2 (6.2)	6.0 (6)	12 (16)	12.5 (12.5)	19 (19)	20	22 (22)	27
	DS2000 (μDS) 230 Vac M	1300(1600)	3400(3400)	1700(1700)	2250	1550	3100	1900	3300
Rotor inertia (resolver included) <i>Momento d'inerzia rotorico (con resolver)</i>	DBS / DBM04 V	1700	4000	2500	2800	2000	2600	1700	2400
	DS2000 (μDS) 400 Vac V	2000(1500)	4700(4500)	2900(2100)	3300(3300)	2100(2100)	3100	2000(2000)	2800
Output power, continuous duty, nominal speed ( $\Delta\theta$ win = 65°C°) <i>Potenza resa in servizio continuo alla vel. nom. (<math>\Delta\theta</math> avv = 65°C°)</i>		0.54	0.75	0.97	1.13	1.29	1.41	1.6	1.65
Output power, continuous duty, nominal speed ( $\Delta\theta$ win = 110°C°) <i>Potenza resa in servizio continuo alla velocità nom. (<math>\Delta\theta</math> avv = 110°C°)</i>		0.73	1.19	1.28	1.74	1.92	2.44	2.38	3.06
Mechanical time constant <i>Costante di tempo meccanica</i>	M	3.88	3.89	2.09	2.13	1.27	1.30	1.18	1.20
Weight / <i>Massa</i>	V	3.63	3.62	2.05	1.95	1.41	1.43	1.26	1.29
Thermal time constant / <i>Costante di tempo termica</i>		4.2	4.2	6.2	6.2	8.5	8.5	10	10
Torque constant <i>Costante di coppia</i>	M	1290	1290	1380	1380	1500	1500	1560	1560
Electrical time constant <i>Costante di tempo elettrica</i>	M	0.79	0.41	0.81	0.54	0.81	0.54	0.83	0.58
	V	1.30	0.67	1.21	0.96	1.44	0.97	1.55	1.01
Winding resistance at 20°C (phase to phase) <i>Resistenza a 20°C tra le fasi</i>	M	4.31	4.43	5.89	5.83	8.08	7.86	7.83	7.65
Winding inductance (phase to phase) <i>Induttanza tra le fasi</i>	V	4.61	4.77	6.01	6.35	7.23	7.13	7.29	7.14
	M	5.54	1.4	2	0.9	0.92	0.42	0.69	0.34
Nominal current, locked rotor••• <i>Corrente nominale a rotore bloccato•••</i>	V	12.97	3.42	4.02	2.57	3.3	1.45	2.6	1.13
	M	23	6.2	11.3	5.07	7.43	3.3	5.4	2.6
Power terminal board (see page 27) <i>Morsettiera potenza (vedere pag.27)</i>	V	61.6	16.8	25.05	15.8	23.2	10.7	18.8	8
	M	2.6	5.2	4.8	7.2	7.3	10.9	8.9	12.8
Power connector (see page 27) <i>Connettore potenza (vedere pag.27)</i>	V	1.6	3.1	3.2	4.1	4.1	6.1	4.8	7.3
	M	A	A	A	A	A	A	A	A
Recommended power cable square section (4x) <i>Sezione cavo consigliata (4x)</i>	V	A	A	A	A	A	A	A	A
	M	A	A	A	A	B	B	B	B
Recommended power cable square section (4x) <i>Sezione cavo consigliata (4x)</i>	V	A	A	A	A	B	B	B	B
	M	1.0 (18)	1.5 (16)	1.5 (16)	1.5 (14)	1.5 (14)	2.5 (10)	2.5 (10)	2.5 (10)
	V	1.0 (18)	1.0 (18)	1.0 (18)	1.0 (18)	1.0 (18)	1.5 (16)	1.5 (16)	2.5 (14)

M / V / • / •• / ••• / \* / ■ / ▼ see general remarks on page 24 / vedere note generali a pag. 24

FAS F1								Symbol Simbolo	Unit Unità
M2 030	M2 060	M4 030	M4 045	M6 030	M6 045	M8 030	M8 045		
V2 030	V2 060	V4 030	V4 045	V6 030	V6 045	V8 030	V8 045		
2	2	4	4	6	6	8	8	nr / n	
3.0	3.0	5.6	5.6	8.3	8.3	10.3	10.3	$T_{n65}$	Nm
3.7	3.7	6.8	6.8	10	10	12.6	12.6	$T_{n110}$	Nm
10	10	18	18	24	24	30	30	$T_m$	Nm
6/11(6/16*)	14/30*	8/16	14/30	14/30	25/49*	14/30	25/49	Drive Type Tipo azionamento	
3/6	6/11	6/11	8/16	8/16	15/30*	8/16	15/30		
3/6 (3/8)	6/11 (6/16)	6/11 (6/16)	8/16	8/16	14/30*	8/16	14/30		
8.1(10)	10	12.5	16	24	24	24	28	$T_{md}$	Nm
8	6.8	12.4	14	21.5	24	23	28		
8 (9.5)	6.8 (9.5)	12.4 (18)	14	21.5	24	23	28	$\omega n$	rpm - r/min
3000	6000	3000	4500	3000	4500	3000	4500	$T_{n\omega}$	Nm
2.8	2.4	5	4.6	7.0	6.4	8.8	7.9	$T_{n\omega}$	Nm
3.5	3.2	6.4	6.2	9.2	8.8	11.6	10.9		
5(5)	5.5	10.5	12	18	19	21	24	$T_{md\omega}$	Nm
5.2	5.5	11.5	11	16	17	20	24		
6.2 (6.2)	6.0 (6.0)	12 (16)	12.5	19	20	22	27	$\omega\tau$	rpm - r/min
1300(1000)	2400	1700	2250	1550	2400	1900	2500		
1700	4000	2500	2800	2000	2600	1700	2400	$P_{out}$	kW
2000(1800)	4700(4500)	2900(2100)	3300	2100	3100	2000	2800	$P_{out}$	kW
0.88	1.51	1.57	2.17	2.2	3.02	2.76	3.72	$J$	10 <sup>-6</sup> kgm <sup>2</sup>
1.10	2.01	2.01	2.92	2.89	4.15	3.64	5.14	$\tau_m$	ms
265	265	415	415	525	525	680	680	$m$	kg
3.88	3.89	2.09	2.13	1.27	1.30	1.18	1.20	$\tau_{th}$	s
3.63	3.62	2.05	1.95	1.41	1.43	1.26	1.29	$K_t$	Nm/A
5.7	5.7	8	8	10.3	10.3	12	12	$\tau_e$	ms
775	775	830	830	900	900	940	940	$R_w$	$\Omega$
0.79	0.41	0.81	0.54	0.81	0.54	0.83	0.58	$L_w$	mH
1.30	0.67	1.21	0.96	1.44	0.97	1.55	1.01	$I_n$	A
4.31	4.43	5.89	5.83	8.08	7.86	7.83	7.65	Type / Tipo	
4.61	4.77	6.01	6.35	7.23	7.13	7.29	7.14	Type / Tipo	
5.54	1.4	2	0.9	0.92	0.42	0.69	0.34	mm <sup>2</sup> (AWG)	
12.97	3.42	4.02	2.57	3.3	1.45	2.6	1.13		
23	6.2	11.3	5.07	7.43	3.3	5.4	2.6		
61.6	16.8	25.05	15.8	23.2	10.7	18.8	8		
4.7	9.1	8.4	12.6	12.3	18.5	15.2	21.8		
2.8	5.5	5.6	7.1	7.0	10.3	8.1	12.5		
A	A	A	A	A	A	A	A		
A	A	A	A	A	A	A	A		
A	A	B	B	B	B	B	B		
A	A	B	B	B	B	B	B		
1.0 (18)	2.5 (14)	2.5 (14)	2.5 (14)	2.5 (14)	2.5 (10)	2.5 (10)	6.0 (8)		
1.0 (18)	1.5 (16)	1.5 (16)	1.5 (16)	1.5 (16)	2.5 (14)	2.5 (14)	4.0 (10)		

**PERFORMANCE SPECIFICATIONS / DATI RENDIMENTO**

Characteristics and nominal values with sinusoidal drive <i>Caratteristiche e valori nominali con azionamento sinusoidale</i>	Motor Size <i>Taglia Motore</i>	FAS T2								
		M	M2 030	M2 045	M4 020	M4 030	M6 020	M6 030	M8 020	M8 030
		V	V2 030	V2 045	V4 020	V4 030	V6 020	V6 030	V8 020	V8 030
Number of rotor modules / <i>Numero dei moduli rotore</i>		2	2	4	4	6	6	8	8	
Torque, continuous duty, locked rotor $\Delta\theta$ win=65°C° <i>Coppia in servizio cont., rotore bloccato con <math>\Delta\theta</math> avv=65°C°</i>	M	7.5	7.5	12.5	12.5	18	18	23	23	
	V	7.5	7.5	13.5	13.5	19	19	24	24	
Torque, continuous duty, locked rotor $\Delta\theta$ win=110°C° <i>Coppia in servizio continuo, rotore bloccato con <math>\Delta\theta</math> avv=110°C°</i>	M	9.1	9.1	15	15	22	22	28.2	28.2	
	V	9.6	9.6	17.5	17.5	24	24	30	30	
Peak torque / <i>Coppia di picco</i>		25	25	45	45	66	66	83	83	
Recommended drive <i>Azionamento consigliato</i>	DS2000 230 Vac M	8/16	14/30	14/30	14/30	14/30	25/49	25/49	25/49	
	DBS / DBM04 V	8/16	15/30	8/16	15/30	15/30	15/30	15/30	25/49	
	DS2000 (μDS) 400 Vac V	8/16 (6/16)	14/30	8/16 (6/16)	14/30	14/30	14/30	14/30	25/49	
Max torque with recommended drive <i>Coppia max con azionamento consigliato</i>	DS2000 230 Vac M	12.5	15	35	23	35	40	59	42	
	DBS / DBM04 V	22	25	34	43	65	45	65	72	
	DS2000 (μDS) 400 Vac V	22(22)	25	34(34)	43	65	45	65	72	
Nominal speed / <i>Velocità nominale</i>		3000	4500	2000	3000	2000	3000	2000	3000	
Nominal torque, continuous duty, nominal speed ( $\Delta\theta$ win = 65°C°) <i>Coppia nom. in servizio continuo, velocità nom (<math>\Delta\theta</math> avv = 65°C°)</i>	M	5.5	4	10.8	8.8	14	10	15.9	11.4	
	V	5.6	4.1	12.3	9.5	15.7	10.8	18.6	11.4	
Nominal torque, continuous duty, nominal speed ( $\Delta\theta$ win = 110°C°) <i>Coppia nom. in servizio continuo, velocità nom (<math>\Delta\theta</math> avv = 110°C°)</i>	M	8	6.8	14.7	12.5	17.8	16	22	19	
	V	8	6.8	14.7	13.5	20	17.3	25	21	
Max torque at nominal speed with recomm. drive** / <i>Coppia max alla velocità nom. con azion. consigliato**</i>	DS2000 230 Vac M	11	14	28	22	34	37	55	41	
	DBS / DBM04 V	17	20	30	35	52	42	60	67	
	DS2000 (μDS) 400 Vac V	19 (19)	23	32 (32)	40	60	44	63	70	
Cutoff speed at max torque with recom. dri <i>Velocità di taglio alla coppia max</i>	DS2000 230 Vac M	2000	3200	1100	2400	1600	2200	1200	2400	
	DBS / DBM04 V	1500	2200	1000	1500	1000	1500	1200	1700	
	DS2000 (μDS) 400 Vac V	1800(1800)	2500	1200(1200)	1700	1200	1700	1400	2000	
Output power, continuous duty, nominal speed ( $\Delta\theta$ win = 65°C°) <i>Potenza resa in servizio continuo alla vel. nom. (<math>\Delta\theta</math> avv = 65°C°)</i>	M	1.73	1.88	2.24	2.79	2.93	3.14	3.33	3.58	
	V	1.9	1.95	2.59	3	3.3	3.4	3.9	3.6	
Output power, continuous duty, nom. speed ( $\Delta\theta$ win = 110°C°) <i>Potenza resa in servizio cont. alla vel. nom. (<math>\Delta\theta</math> avv = 110°C°)</i>	M	2.51	3.2	3.08	3.93	3.73	5.03	4.61	5.97	
	V	2.51	3.2	3.08	4.24	4.19	5.43	5.24	6.6	
Rotor inertia (resolver included) <i>Momento d'inerzia rotorico (con resolver)</i>		1450	1450	2350	2350	3400	3400	4500	4500	
Mechanical time constant <i>Costante di tempo meccanica</i>	M	4.47	4.54	2.61	2.58	2.10	2.22	2.05	1.95	
	V	3.54	3.49	1.95	1.99	1.62	1.54	1.38	1.39	
Weight / <i>Massa</i>		11	11	16	16	21	21	26	26	
Thermal time constant / <i>Costante di tempo termica</i>		1180	1180	1400	1400	1550	1550	1700	1700	
Torque constant <i>Costante di coppia</i>	M	0.88	0.56	1.31	0.85	1.28	0.88	1.31	0.92	
	V	1.59	0.95	2.38	1.59	2.38	1.67	2.38	1.59	
Electrical time constant <i>Costante di tempo elettrica</i>	M	7.19	6.96	9.55	9.57	11.03	10.51	10.67	11.19	
	V	6.18	6.27	8.71	8.54	9.68	10.16	10.8	10.67	
Winding resistance at 20°C (phase to phase) <i>Resistenza a 20°C tra le fasi</i>	M	1.39	0.56	1.1	0.45	0.58	0.30	0.45	0.23	
	V	3.4	1.22	2.61	1.17	1.38	0.67	0.97	0.45	
Winding inductance (phase to phase) <i>Induttanza tra le fasi</i>	M	10	3.9	10.5	4.4	6.4	3.1	4.8	2.35	
	V	21.95	7.9	23.6	10.5	15.1	7.4	10.8	4.8	
Nominal current, locked rotor*** <i>Corrente nominale a rotore bloccato***</i>	M	8.5	13.5	9.5	14.7	14.1	20.4	17.6	25.1	
	V	4.7	7.9	5.7	8.5	8.0	11.4	10.1	15.1	
Power terminal board (see page 27) <i>Morsettiera potenza (vedere pag.27)</i>	M	B	B	B	B	B	B	B	B	
	V	B	B	B	B	B	B	B	B	
Power connector (see page 27) <i>Connettore potenza (vedere pag.27)</i>	M	B	B	B	B	B	B	B	B	
	V	B	B	B	B	B	B	B	B	
Recommended power cable square section (4x) <i>Sezione cavo consigliata (4x)</i>	M	2.5 (14)	2.5 (10)	2.5 (14)	2.5 (10)	2.5 (10)	6.0 (8)	6.0 (8)	6.0 (8)	
	V	1.5 (16)	2.5 (14)	1.5 (16)	2.5 (14)	2.5 (14)	2.5 (14)	2.5 (14)	4.0 (10)	

M / V / • / \*\* / \*\*\* / \* / ■ / ▼ see general remarks on page 24 / vedere note generali a pag. 24

FAS F2								Symbol Simbolo	Unit Unità
M2 030	M2 045	M4 020	M4 030	M6 020	M6 030	M8 020	M8 030	nr / n	
V2 030	V2 045	V4 020	V4 030	V6 020	V6 030	V8 020	V8 030	$T_{n65}$	Nm
2	2	4	4	6	6	8	8		
9.6	9.6	15.8	15.8	23	23	30	30		
9.6	9.6	17.4	17.4	24.5	24.5	31	31		
11.7	11.7	19.3	19.3	28	28	36	36		
11.7	11.7	21	21	30	30	38	38		
25	25	45	45	66	66	83	83		
14/30*	25/49	14/30	25/49	25/49	30/64	30/64	30/64		
8/16	15/30	8/16	15/30	15/30	25/49*	15/30	25/49		
8/16	14/30	8/16	14/30	14/30	25/49*	14/30	25/49		
25	25	35	38	58	51	76	53		
22	25	34	43	65	66	65	72		
22	25	34	43	65	66	65	72		
3000	4500	2000	3000	2000	3000	2000	3000		
8.5	7.3	14.4	13.2	20	18	22	19.5		
8.5	7.3	15.5	14.5	22	18.8	25	22		
11	10	17.6	17	25	22.8	28	27.5		
11	10	19	18.5	27.5	24	32	31		
14	16	28	30	47	45	63	50		
17	20	30	35	52	54	60	67		
19	23	32	40	60	60	63	70		
1200	2200	1100	1800	1200	1900	1200	2200		
1500	2200	1000	1500	1000	1400	1200	1700		
1800	2500	1200	1700	1200	1600	1400	2000		
2.7	3.44	3.02	4.15	4.19	5.65	4.60	6.12		
2.7	3.44	3.2	4.55	4.60	5.90	5.24	6.90		
3.46	4.71	3.69	5.34	5.24	7.16	5.86	8.64		
3.46	4.71	3.98	5.81	5.76	7.54	6.70	9.74		
1450	1450	2350	2350	3400	3400	4500	4500		
4.47	4.54	2.61	2.58	2.10	2.22	2.05	1.95		
3.54	3.49	1.95	1.99	1.62	1.54	1.38	1.39		
14	14	20	20	25	25	31.2	31.2		
710	710	840	840	930	930	1020	1020		
0.88	0.56	1.31	0.85	1.28	0.88	1.31	0.92		
1.59	0.95	2.38	1.59	2.38	1.67	2.38	1.59		
7.19	6.96	9.55	9.57	11.03	10.51	10.67	11.19		
6.18	6.27	8.71	8.54	9.68	10.16	10.8	10.67		
1.39	0.56	1.1	0.45	0.58	0.3	0.45	0.23		
3.4	1.22	2.61	1.17	1.38	0.67	0.97	0.45		
10	3.9	10.5	4.4	6.4	3.1	4.8	2.35		
21.95	7.9	23.6	10.5	15.1	7.4	10.8	4.8		
13.2	21.0	14.7	22.7	21.9	31.7	27.5	39.3		
7.4	12.3	8.8	13.2	12.6	18.0	16.0	23.9		
B	B	B	B	B	B	B	B		
B	B	B	B	B	B	B	B		
B	B	B	B	B	B	B	B		
B	B	B	B	B	B	B	B		
2.5 (10)	6.0 (8)	2.5 (10)	6.0 (8)	6.0 (8)	10.0 (8)	6.0 (8)	10.0 (8)		
2.5 (14)	2.5 (10)	2.5 (14)	2.5 (10)	2.5 (10)	4.0 (10)	4.0 (10)	6.0 (8)		
								$T_{n110}$	Nm
								$T_m$	Nm
								Drive Type Tipo azionamento	
								$T_{md}$	Nm
								$\omega n$	rpm - r/min
								$T_{n\omega}$	Nm
								$T_{n\omega}$	Nm
								$T_{md\omega}$	Nm
								$\omega\tau$	rpm - r/min
								$P_{out}$	kW
								$P_{out}$	kW
								$J$	10 <sup>-6</sup> kgm <sup>2</sup>
								$\tau_m$	ms
								$m$	kg
								$\tau_{th}$	s
								$K_t$	Nm/A
								$\tau_e$	ms
								$R_w$	Ω
								$L_w$	mH
								$I_n$	A
								Type / Tipo	
								Type / Tipo	
								mm <sup>2</sup> (AWG)	



**PERFORMANCE SPECIFICATIONS / DATI RENDIMENTO**

Characteristics and nominal values with sinusoidal drive <i>Caratteristiche e valori nominali con azionamento sinusoidale</i>	Motor Size <i>Taglia Motore</i>		FAS T3			
	M	V	M2 020	M2 030	M3 020	M3 030 <sup>■</sup>
			V2 020	V2 030	V3 020	V3 030 <sup>▼</sup>
Number of rotor modules / <i>Numero dei moduli rotore</i>			2	2	3	3
Nominal torque, continuous duty, locked rotor $\Delta\theta$ win=65°C <sup>•</sup> <i>Coppia nom. in servizio cont., rotore bloccato con <math>\Delta\theta</math> avv=65°C<sup>•</sup></i>			26	26	36	36
Torque, continuous duty, locked rotor $\Delta\theta$ win=110°C <sup>•</sup> <i>Coppia in servizio continuo, rotore bloccato con <math>\Delta\theta</math> avv=110°C<sup>•</sup></i>			32	32	44	44
Peak torque / <i>Coppia di picco</i>			70	70	105	105
Recommended drive <i>Azionamento consigliato</i>	DS2000 230 Vac	M	25/49	30/64	30/64	50/99
	DBS / DBM04	V	15/30	25/49	25/49	35/64
	DS2000 400 Vac	V	14/30	25/49	25/49	30/64
Max torque with recommended drive <i>Coppia max con azionamento consigliato</i>	DS2000 230 Vac	M	58	52	79	81
	DBS / DBM04	V	59	66	96	94
	DS2000 400 Vac	V	59	66	96	94
Nominal speed / <i>Velocità nominale</i>			2000	3000	2000	3000
Nominal torque, continuous duty, nominal speed ( $\Delta\theta$ win=65°C <sup>•</sup> ) <i>Coppia nominale in servizio continuo, velocità nom. (<math>\Delta\theta</math> avv = 65°C<sup>•</sup>)</i>			20	13	26	19
Nominal torque, continuous duty, nominal speed ( $\Delta\theta$ win=110°C <sup>•</sup> ) <i>Coppia nominale in servizio continuo, velocità nom. (<math>\Delta\theta</math> avv = 110°C<sup>•</sup>)</i>			25	17	32	28
Max torque at nominal speed with recom. drive <i>Coppia max con azionamento consigliato alla velocità nominale</i>	DS2000 230 Vac	M	56	50	76	74
	DBS / DBM04	V	56	61	91	58
	DS2000 400 Vac	V	58	65	94	69
Cutoff speed at max torque with recom. drive <sup>••</sup> <i>Velocità di taglio alla coppia max con azionamento consigliato<sup>••</sup></i>	DS2000 230 Vac	M	1800	2500	1700	2200
	DBS / DBM04	V	1400	2000	1300	1400
	DS2000 400 Vac	V	1600	2400	1500	1600
Output power, continuous duty, nominal speed ( $\Delta\theta$ win = 65°C <sup>•</sup> ) <i>Potenza resa in servizio continuo alla velocità nom. (<math>\Delta\theta</math> avv = 65°C<sup>•</sup>)</i>			4.1	4	5.4	5.9
Output power, continuous duty, nominal speed ( $\Delta\theta$ win = 110°C <sup>•</sup> ) <i>Potenza resa in servizio continuo alla velocità nom. (<math>\Delta\theta</math> avv = 110°C<sup>•</sup>)</i>			5.2	5.3	6.7	8.8
Rotor inertia (resolver included) <i>Momento d'inerzia rotorico (con resolver)</i>			11300	11300	15150	15150
Mechanical time constant <i>Costante di tempo meccanica</i>		M	3.78	3.73	2.76	2.67
		V	4.24	4.17	3.17	3.32
Weight / <i>Massa</i>			29	29	37	37
Thermal time constant / <i>Costante di tempo termico</i>			1850	1850	2050	2050
Torque constant <i>Costante di coppia</i>		M	1.18	0.82	1.24	0.83
		V	2.05	1.37	2.06	1.54
Electrical time constant <i>Costante di tempo elettrica</i>		M	13.57	13.67	16.42	16.86
		V	13.6	13.83	16.41	15.67
Winding resistance at 20°C (phase to phase) <i>Resistenza a 20°C tra le fasi</i>		M	0.269	0.128	0.164	0.07
		V	0.88	0.41	0.52	0.3
Winding inductance (phase to phase) <i>Induttanza tra le fasi</i>		M	3.65	1.75	2.66	1.18
		V	12.4	5.53	8.4	4.7
Nominal current, locked rotor ( $\Delta\theta$ win = 65°C) <i>Corrente nominale a rotore bloccato (<math>\Delta\theta</math> avv = 65°C)</i>		M	22	31.7	29	43.5
		V	12.7	19	17.5	23.3
Power terminal board (see page 27) <i>Morsettiera potenza (vedere p. 27)</i>		M	B	B	B	B
		V	B	B	B	B
Power connector (see page 27) <i>Connettore potenza (vedere p. 27)</i>		M	B	B	C	C
		V	B	B	B	B
Recommended power cable square section (4x) <i>Sezione cavo consigliata (4x)</i>		M	6.0 (8)	6.0 (8)	6.0 (8)	10.0 (8)
		V	4.0 (10)	4.0 (10)	4.0 (10)	6.0 (8)

M / V / • / •• / ••• / \* / ■ / ▼ see general remarks on page 24 / vedere note generali a pag. 24

FAS T3						Symbol <i>Simbolo</i>	Unit <i>Unità</i>
M4 020 V4 020	M4 030 <sup>■</sup> V4 030 <sup>▼</sup>	M6 012 V6 012	M6 020 V6 020	M8 012 V8 012	M8 020 <sup>■</sup> V8 020 <sup>▼</sup>	nr / n	
4	4	6	6	8	8		
48	48	68	68	87	87	$T_{n65}$	Nm
59	59	83	83	106	106	$T_{n110}$	Nm
127	127	190	190	240	240	$T_m$	Nm
50/99	60/127	30/64	60/127	50/99	100/170	Drive Type <i>Tipo azionamento</i>	
25/49	35/64	25/49	35/64	35/64	50/99		
25/49	30/64	25/49	30/64	30/64	50/99		
127	93	139	174	216	185	$T_{md}$	Nm
107	95	172	159	235	239		
107	95	172	159	235	239		
2000	3000	1200	2000	1200	2000	$\omega n$	rpm - r/min
34	17	55	47	72	54	$T_n\omega$	Nm
42	37	66	55	81	69	$T_n\omega$	Nm
120	90	135	162	200	182		
101	70	160	140	213	160	$T_{md}\omega$	Nm
105	81	168	149	231	168		
1500	2500	1000	1400	850	1700		
1400	1600	800	1300	800	900	$\omega\tau$	rpm - r/min
1600	1800	900	1500	900	1000		
7.1	5.3	7.1	9.8	9	11.3	$P_{out}$	kW
8.8	11.6	8.3	11.5	10.1	14.4	$P_{out}$	kW
21000	21000	30175	30175	41150	41150	$J$	10 <sup>-6</sup> kgm <sup>2</sup>
2.49	2.39	2.14	2.11	1.97	1.94	$\tau m$	ms
2.88	2.91	2.50	2.43	2.35	2.27	$m$	kg
46	46	61	61	78	78	$\tau th$	s
2270	2270	2550	2550	3050	3050	$K_t$	Nm/A
1.29	0.74	2.2	1.38	2.2	1.1		
2.26	1.55	3.61	2.58	3.78	2.42		
18.25	18.89	19.34	19.48	20.60	20.91	$\tau_e$	ms
17.75	17.92	18.75	19.35	19.66	20.22		
0.114	0.037	0.198	0.077	0.134	0.033	$R_w$	$\Omega$
0.39	0.193	0.59	0.31	0.463	0.184	$L_w$	mH
2.08	0.68	3.83	1.5	2.76	0.69		
7.17	3.44	11.7	6	9.28	3.76		
37.3	65.2	30.8	49.3	39.4	78.8	$I_n$	A
21.2	30.9	18.8	26.4	22.9	36		
B	B	B	B	B	B	Type / <i>Tipo</i>	
B	B	B	B	B	B		
C	C	C	C	C	C	Type / <i>Tipo</i>	
B	B	B	B	B	B		
10.0 (8)	16.0 (6)	10.0 (8)	10.0 (8)	10.0 (8)	16.0 (6)	mm <sup>2</sup> (AWG)	
6.0 (8)	10.0 (8)	4.0 (10)	10.0 (8)	6.0 (8)	10.0 (8)		

**PERFORMANCE SPECIFICATIONS / DATI RENDIMENTO**

Characteristics and nominal values with sinusoidal drive <i>Caratteristiche e valori nominali con azionamento sinusoidale</i>	Motor Size <i>Taglia Motore</i>		FAS F3			
	M	V	M2 020	M2 030	M3 020	M3 030 <sup>■</sup>
			V2 020	V2 030	V3 020	V3 030 <sup>▼</sup>
Number of rotor modules / <i>Numero dei moduli rotore</i>			2	2	3	3
Torque, continuous duty, locked rotor $\Delta\theta$ win=65°C <sup>•</sup> <i>Coppia in servizio continuo, rotore bloccato con <math>\Delta\theta</math> avv=65°C<sup>•</sup></i>			33	33	45	45
Nominal torque, continuous duty, locked rotor $\Delta\theta$ win=110°C <sup>•</sup> <i>Coppia nom. in servizio continuo, rotore bloccato con <math>\Delta\theta</math> avv=110°C<sup>•</sup></i>			40	40	55	55
Peak torque / <i>Coppia di picco</i>			70	70	105	105
Recommended drive <i>Azionamento consigliato</i>	DS2000 230 Vac	M	30/64*	50/99*	50/99*	60/127
	DBS / DBM04	V	25/49	25/49	25/49	35/64
Max torque with recommended drive <i>Coppia max con azionamento consigliato</i>	DS2000 400 Vac	V	25/49	25/49	25/49	30/64
	DS2000 230 Vac	M	70	70	105	104
Nominal speed / <i>Velocità nominale</i>	DBS / DBM04	V	70	66	96	94
	DS2000 400 Vac	V	70	66	96	94
Nominal torque, continuous duty, nominal speed ( $\Delta\theta$ win = 65°C <sup>•</sup> ) <i>Coppia nominale in servizio continuo, velocità nom. (<math>\Delta\theta</math> avv = 65°C<sup>•</sup>)</i>			2000	3000	2000	3000
Nominal torque, continuous duty, nominal speed ( $\Delta\theta$ win = 110°C <sup>•</sup> ) <i>Coppia nominale in servizio continuo, velocità nom. (<math>\Delta\theta</math> avv = 110°C<sup>•</sup>)</i>			24	18	32	30
Max torque at nominal speed with recom. drive DS2000 230 Vac <i>Coppia max con azionamento consigliato alla velocità nominale</i>	DS2000 230 Vac	M	65	65	95	86
Cutoff speed at max torque with recom. drive <sup>••</sup> <i>Velocità di taglio alla coppia max con azionamento consigliato<sup>••</sup></i>	DBS / DBM04	V	62	61	91	58
	DS2000 400 Vac	V	68	65	94	69
Output power, continuous duty, nominal speed ( $\Delta\theta$ win = 65°C <sup>•</sup> ) <i>Potenza resa in servizio continuo alla velocità nom. (<math>\Delta\theta</math> avv = 65°C<sup>•</sup>)</i>	DS2000 230 Vac	M	1500	2200	1500	1800
	DBS / DBM04	V	1200	2000	1300	1400
Output power, continuous duty, nominal speed ( $\Delta\theta$ win = 110°C <sup>•</sup> ) <i>Potenza resa in servizio continuo alla velocità nom. (<math>\Delta\theta</math> avv = 110°C<sup>•</sup>)</i>	DS2000 400 Vac	V	1400	2400	1500	1600
Rotor inertia (resolver included) <i>Momento d'inerzia rotorico (con resolver)</i>			11300	11300	15150	15150
Mechanical time constant <i>Costante di tempo meccanica</i>	M		3.78	3.73	2.76	2.67
	V		4.24	4.17	3.17	3.32
Weight / <i>Massa</i>			34	34	42	42
Thermal time constant / <i>Costante di tempo termica</i>			1110	1110	1230	1230
Torque constant <i>Costante di coppia</i>	M		1.18	0.82	1.24	0.83
	V		2.05	1.37	2.06	1.54
Electrical time constant <i>Costante di tempo elettrica</i>	M		13.57	13.67	16.42	16.86
	V		13.6	13.83	16.41	15.67
Winding resistance at 20°C (phase to phase) <i>Resistenza a 20°C tra le fasi</i>	M		0.269	0.128	0.164	0.07
	V		0.88	0.41	0.52	0.3
Winding inductance (phase to phase) <i>Induttanza tra le fasi</i>	M		3.65	1.75	2.66	1.18
	V		12.4	5.53	8.4	4.7
Nominal current, locked rotor ( $\Delta\theta$ win = 110°C) <i>Corrente nominale a rotore bloccato (<math>\Delta\theta</math> avv = 110°C)</i>	M		33.9	48.8	44.4	66.3
	V		19.5	29.2	26.7	35.7
Power terminal board (see page 27) <i>Morsettiera potenza (vedere p. 27)</i>	M		B	B	B	B
	V		B	B	B	B
Power connector (see page 27) <i>Connettore potenza (vedere p. 27)</i>	M		B	C	C	C
	V		B	B	B	B
Recommended power cable square section (4x) <i>Sezione cavo consigliata (4x)</i>	M		6.0 (8)	10.0 (8)	10.0 (8)	10.0 (6)
	V		4.0 (10)	6.0 (8)	6.0 (8)	10.0 (8)

M / V / • / •• / ••• / \* / ■ / ▼ see general remarks on page 24 / vedere note generali a pag. 24

FAS F3						Symbol Simbolo	Unit Unità
M4 020 V4 020	M4 030 <sup>■</sup> V4 030 <sup>▼</sup>	M6 012 V6 012	M6 020 V6 020	M8 012 V8 012	M8 020 <sup>■</sup> V8 020 <sup>▼</sup>	nr / n	
4	4	6	6	8	8		
61	61	86	86	110	110	$T_{n65}$	Nm
74	74	105	105	135	135	$T_{n110}$	Nm
127	127	190	190	240	240	$T_m$	Nm
60/127*	100/170	50/99*	100/170*	60/127*	100/170	Drive Type Tipo azionamento	
35/64	50/99	35/64	50/99	35/64	60/127		
30/64	50/99	30/64	50/99	30/64	60/127		
127	124	190	190	240	185	$T_{md}$	Nm
127	127	190	190	235	240		
127	127	190	190	235	240		
2000	3000	1200	2000	1200	2000	$\omega n$	rpm - r/min
42	38	70	52	88	70	$T_n\omega$	Nm
58	57	93	74	110	108	$T_n\omega$	Nm
120	108	173	172	227	182		
113	72	172	156	213	160	$T_{md}\omega$	Nm
123	80	175	160	231	165		
1500	2000	900	1300	800	1700		
1200	1200	700	1100	800	900	$\omega\tau$	rpm - r/min
1400	1400	800	1200	900	1000		
8.8	11.9	8.8	10.9	11.1	14.7	$P_{out}$	kW
12.1	17.9	11.6	15.5	13.8	22.5	$P_{out}$	kW
21000	21000	30175	30175	41150	41150	$J$	10 <sup>-6</sup> kgm <sup>2</sup>
2.49	2.39	2.14	2.11	1.97	1.94	$\tau m$	ms
2.88	2.91	2.50	2.43	2.35	2.27	$m$	kg
52	52	71	71	89	89	$\tau th$	s
1360	1360	1530	1530	1830	1830	$K_t$	Nm/A
1.29	0.74	2.20	1.38	2.20	1.10		
2.26	1.55	3.61	2.58	3.78	2.42		
18.25	18.89	19.34	19.48	20.60	20.91	$\tau_e$	ms
17.75	17.92	18.75	19.35	19.66	20.22		
0.114	0.037	0.198	0.077	0.134	0.033	$R_w$	$\Omega$
0.39	0.193	0.59	0.31	0.463	0.184		
2.08	0.68	3.83	1.5	2.76	0.69	$L_w$	mH
7.17	3.44	11.7	6	9.28	3.76		
57.4	100.0	47.7	76.1	61.4	122.7	$I_n$	A
32.7	47.7	29.1	40.7	35.7	55.8		
B	C	B	B	B	C	Type / Tipo	
B	B	B	B	B	B		
C	C	C	C	C	C		
B	C	B	B	B	C	Type / Tipo	
16.0 (6)	25.0 (4)	10.0 (8)	16.0 (6)	16.0 (6)	25.0 (4)	mm <sup>2</sup> (AWG)	
10.0 (8)	10.0 (8)	6.0 (8)	10.0 (8)	10.0 (8)	16.0 (6)		

**PERFORMANCE SPECIFICATIONS / DATI RENDIMENTO**

Characteristics and nominal values with sinusoidal drive <i>Caratteristiche e valori nominali con azionamento sinusoidale</i>	Motor Size <i>Taglia Motore</i>  V	FAS T4			
		V2 017	V2 022 <sup>▼</sup>	V3 012	V3 020 <sup>▼</sup>
Number of rotor modules / <i>Numero dei moduli rotore</i>		2	2	3	3
Torque, continuous duty, locked rotor $\Delta\theta$ win=65°C <sup>•</sup> <i>Coppia in servizio continuo, rotore bloccato con <math>\Delta\theta</math> avv=65°C<sup>•</sup></i>		105	105	157	157
Nominal torque, continuous duty, locked rotor $\Delta\theta$ win=110°C <sup>•</sup> <i>Coppia nom. in servizio continuo, rotore bloccato con <math>\Delta\theta</math> avv=110°C<sup>•</sup></i>		127	127	190	190
Peak torque / <i>Coppia di picco</i>		300	300	450	450
Recommended drive	DBS / DBM04 V	50/99	60/127	50/99	100/170
<i>Azionamento consigliato</i>	DS2000 400 Vac V	50/99	60/127	50/99	-
Max. Torque with recommended drive	DBS / DBM04 V	290	290	411	410
<i>Coppia max con azionamento consigliato</i>	DS2000 400 Vac V	290	290	411	-
Nominal speed / <i>Velocità nominale</i>		1700	2200	1200	2000
Nominal torque, continuous duty, nominal speed ( $\Delta\theta$ win = 65°C <sup>•</sup> ) <i>Coppia nominale in servizio continuo, velocità nom. (<math>\Delta\theta</math> avv = 65°C<sup>•</sup>)</i>		20	20	70	40
Nominal torque, continuous duty, nominal speed ( $\Delta\theta$ win = 110°C <sup>•</sup> ) <i>Coppia nominale in servizio continuo, velocità nom. (<math>\Delta\theta</math> avv = 110°C<sup>•</sup>)</i>		78	78	132	110
Max torque at nominal speed with recommended drive	DBS / DBM04 V	260	220	380	300
<i>Coppia max con azionamento consigliato alla velocità nominale</i>	DS2000 400 Vac V	270	225	385	-
Cutoff speed at max torque with recommended drive <sup>••</sup>	DBS / DBM04 V	1000	900	750	1000
<i>Velocità di taglio alla coppia max con azionamento consigliato<sup>••</sup></i>	DS2000 400 Vac V	1200	1000	800	-
Output power, continuous duty, nominal speed ( $\Delta\theta$ win = 65°C <sup>•</sup> ) <i>Potenza resa in servizio continuo alla velocità nom. (<math>\Delta\theta</math> avv = 65°C<sup>•</sup>)</i>		3.60	4.60	8.8	7.10
Output power, continuous duty, nominal speed ( $\Delta\theta$ win = 110°C <sup>•</sup> ) <i>Potenza resa in servizio continuo alla velocità nom. (<math>\Delta\theta</math> avv = 110°C<sup>•</sup>)</i>		13.9	18.0	16.6	19.6
Rotor inertia (resolver included) <i>Momento d'inerzia rotorico (con resolver)</i>		47000	47000	70000	70000
Mechanical time constant <i>Costante di tempo meccanica</i>	V	1.24	1.23	0.94	0.94
Weight / <i>Peso</i>		80	80	104	104
Thermal time constant / <i>Costante di tempo termico</i>		4300	4300	5200	5200
Torque constant <i>Costante di coppia</i>	V	3.26	2.53	4.615	2.714
Electrical time constant <i>Costante di tempo elettrica</i>	V	21.51	21.59	25.66	25.57
Winding resistance at 20°C (phase to phase) <i>Resistenza a 20°C tra le fasi</i>	V	0.146	0.088	0.152	0.058
Winding inductance (phase to phase) <i>Induttanza tra le fasi</i>	V	3.14	1.9	3.9	1.45
Nominal current, locked rotor ( $\Delta\theta$ win = 110°C) <i>Corrente nominale a rotore bloccato (<math>\Delta\theta</math> avv = 110°C)</i>	V	39.0	50.1	41.2	70.0
Power terminal board (see page 27) <i>Morsettiera potenza (vedere p. 27)</i>	V	B	B	B	B
Power connector (see page 27) <i>Connettore potenza (vedere p. 27)</i>	V	B	C	B	C
Recommended power cable square section (4x) <i>Sezione cavo consigliata (4x)</i>	V	10.0 (8)	10.0 (8)	10.0 (8)	16.0 (6)

FAST4 servomotors matchable with 400-460 Vac DBS/DBM04 and 400 Vac DS2000 servomotors  
I motori FAST4 sono da utilizzare con azionamenti DBS/DBM04 e DS2000 a 400 Vac

M / V / • / •• / ••• / \* / ■ / ▼ see general remarks on page 24 / vedere note generali a pag. 24

FAS T4				Symbol <i>Simbolo</i>	Unit <i>Unità</i>
V4 010	V4 015	V5 010	V6 010		
4	4	5	6	<i>nr / n</i>	
210	210	262	324	$T_{n65}$	Nm
254	254	317	392	$T_{n110}$	Nm
600	600	750	920	$T_m$	Nm
60/127	60/127	60/127	100/170	Drive Type <i>Tipo azionamento</i>	
60/127	60/127	60/127	-	$T_{md}$	Nm
600	508	681	910	$\omega n$	rpm / r/min
600	508	681	-	$T_n\omega$	Nm
1000	1500	1000	1000	$T_n\omega$	Nm
100	60	100	90	$T_{md}\omega$	Nm
172	130	200	232	$\omega\tau$	rpm / r/min
510	400	570	750	$P_{out}$	kW
520	410	575	-	$P_{out}$	kW
600	800	600	500	$J$	10 <sup>-6</sup> kgm <sup>2</sup>
650	850	650	-	$\tau m$	ms
10.5	9.40	10.5	9.4	$m$	kg
18.0	20.4	20.9	24.3	$\tau th$	s
91000	91000	114000	147000	$K_t$	Nm/A
0.90	0.90	0.81	0.80	$\tau_e$	ms
126	126	154	185	$R_w$	$\Omega$
6000	6000	6800	7600	$L_w$	mH
5.43	4.34	5.88	6.15	$I_n$	A
26.45	26.43	29.01	29.78	Type / <i>Tipo</i>	
0.153	0.100	0.131	0.110	Type / <i>Tipo</i>	
4.05	3.95	3.8	3.27	mm <sup>2</sup> (AWG)	
46.8	58.5	53.9	63.7		
B	B	B	B		
C	C	C	C		
10.0 (8)	16.0 (6)	16.0 (6)	16.0 (6)		

**PERFORMANCE SPECIFICATIONS / DATI RENDIMENTO**

Characteristics and nominal values with sinusoidal drive <i>Caratteristiche e valori nominali con azionamento sinusoidale</i>	Motor Size <i>Taglia Motore</i>	FAS F4			
		V2 017	V2 022	V3 012	V3 020
Number of rotor modules / <i>Numero dei moduli rotore</i>		2	2	3	3
Torque, continuous duty, locked rotor $\Delta\theta$ win=65°C° <i>Coppia in servizio continuo, rotore bloccato con <math>\Delta\theta</math> avv=65°C°</i>		140	140	210	210
Nominal torque, continuous duty, locked rotor $\Delta\theta$ win=110°C° <i>Coppia nom. in servizio continuo, rotore bloccato con <math>\Delta\theta</math> avv=110°C°</i>		170	170	255	255
Peak torque / <i>Coppia di picco</i>		300	300	450	450
Recommended drive	DBS / DBM04 V	50/99	60/127	50/99	100/170
<i>Azionamento consigliato</i>	DS2000 400 Vac V	50/99	60/127	50/99	-
Max. Torque with recommended drive	DBS / DBM04 V	290	290	411	410
<i>Coppia max con azionamento consigliato</i>	DS2000 400 Vac V	290	290	411	-
Nominal speed / <i>Velocità nominale</i>		1700	2200	1200	2000
Nominal torque, continuous duty, nominal speed ( $\Delta\theta$ win=65°C°) <i>Coppia nominale in servizio continuo, velocità nom. (<math>\Delta\theta</math> avv=65°C°)</i>		82	50	135	80
Nominal torque, continuous duty, nominal speed ( $\Delta\theta$ win=110°C°) <i>Coppia nominale in servizio continuo, velocità nom. (<math>\Delta\theta</math> avv=110°C°)</i>		125	108	200	143
Max torque at nominal speed with recommended drive	DBS / DBM04 V	260	250	380	378
<i>Coppia max con azionamento consigliato alla velocità nominale</i>	DS2000 400 Vac V	270	260	385	-
Cutoff speed at max torque with recommended drive**	DBS / DBM04 V	1000	1300	750	1300
<i>Velocità di taglio alla coppia max con azionamento consigliato**</i>	DS2000 400 Vac V	1200	1400	800	-
Output power, continuous duty, nominal speed ( $\Delta\theta$ win=65°C°) <i>Potenza resa in servizio continuo alla velocità nom. (<math>\Delta\theta</math> avv=65°C°)</i>		14.60	11.50	17	16.8
Output power, continuous duty, nominal speed ( $\Delta\theta$ win=110°C°) <i>Potenza resa in servizio continuo alla velocità nom. (<math>\Delta\theta</math> avv=110°C°)</i>		22.2	24.9	25.1	29.9
Rotor inertia (resolver included) <i>Momento d'inerzia rotorico (con resolver)</i>		47000	47000	70000	70000
Mechanical time constant	V	1.24	1.23	0.94	0.94
<i>Costante di tempo meccanica</i>					
Weight / <i>Massa</i>		92	92	118	118
Thermal time constant / <i>Costante di tempo termica</i>		2150	2150	2600	2600
Torque constant	V	3.26	2.53	4.615	2.714
<i>Costante di picco</i>					
Electrical time constant	V	21.51	21.59	25.66	25.57
<i>Costante di tempo elettrica</i>					
Winding resistance at 20°C (phase to phase) <i>Resistenza a 20°C tra le fasi</i>	V	0.146	0.088	0.152	0.058
Winding inductance (phase to phase) <i>Induttanza tra le fasi</i>	V	3.14	1.9	3.9	1.45
Nominal current, locked rotor ( $\Delta\theta$ win = 110°C°) <i>Corrente nominale a rotore bloccato (<math>\Delta\theta</math> avv = 110°C°)</i>	V	52.2	67.1	55.3	94.0
Power terminal board (see page 27) <i>Morsettiera potenza (vedere pag. 27)</i>	V	B	B	B	C
Power connector (see page 27) <i>Connettore potenza (vedere pag. 27)</i>	V	C	C	C	C
Recommended power cable square section (4x) <i>Sezione cavo consigliata (4x)</i>	V	16.0 (6)	16.0 (6)	16.0 (6)	25.0 (4)

FASF4 servomotors matchable with 400-460 Vac DBS/DBM04 and 400 Vac DS2000 servomotors  
*I motori FASF4 sono da utilizzare con azionamenti DBS/DBM04 e DS2000 a 400 Vac*

M / V / • / •• / ••• / \* / ■ / ▼ see general remarks on page 24 / *vedere note generali a pag. 24*

FAS F4						Symbol Simbolo	Unit Unità
V4 010	V4 015	V5 010	V5 015	V6 010	V6 015	nr / n	
4	4	5	5	6	6		
280	280	350	350	430	430	$T_{n65}$	Nm
340	340	425	425	522	522	$T_{n110}$	Nm
600	600	750	750	920	920	$T_m$	Nm
60/127	60/127	60/127	100/170	100/170	100/170	Drive Type Tipo azionamento	
60/127	60/127	60/127	-	-	-	$T_{md}$	Nm
600	508	681	685	910	750	$\omega n$	rpm - r/min
600	508	681	-	-	-	$Tn\omega$	Nm
1000	1500	1000	1500	1000	1500	$T_{md}\omega$	Nm
178	130	210	110	310	110	$T_{md}\omega$	Nm
254	225	303	215	375	230	$\omega\tau$	rpm - r/min
510	400	570	500	750	570	$P_{out}$	kW
520	410	575	-	-	-	$P_{out}$	kW
600	800	600	800	500	750	$J$	10 <sup>-6</sup> kgm <sup>2</sup>
650	850	650	-	-	-	$\tau m$	ms
18.60	20.40	22	17.3	32.5	17.3	$m$	kg
26.6	35.3	31.7	33.8	39.3	36.1	$\tau th$	s
91000	91000	114000	114000	147000	147000	$K_t$	Nm/A
0.90	0.90	0.81	0.81	0.80	0.80	$\tau_e$	ms
142	142	172	172	205	205	$R_w$	$\Omega$
3000	3000	3400	3400	3800	3800	$L_w$	mH
5.43	4.34	5.88	4.53	6.15	4.75	$I_n$	A
26.45	26.43	29.01	29.03	29.78	30.00	Type / Tipo	
0.153	0.100	0.131	0.080	0.110	0.071	Type / Tipo	
4.05	3.95	3.8	2.10	3.27	1.93	mm <sup>2</sup> (AWG)	
62.6	78.3	72.3	93.9	84.9	109.9		
C	C	C	C	C	C		
C	C	C	C	C	C		
16.0 (6)	25.0 (4)	16.0 (6)	25.0 (4)	25.0 (4)	25.0 (4)		



**GENERAL REMARKS TO TECHNICAL DATA SHEETS**

**M**= FAS T/F series servomotors matchable with 230 Vac DS2000 and  $\mu$ DS drives  
**V**= FAS T/F series servomotors matchable with 400/460 Vac DBS/DBM04, DS2000 and  $\mu$ DS drives

- ambient at 20°C and flange at 45°C
- see "Torque/Speed Characteristics"
- nominal current referred to Tn110 for FASF motors and Tn65 for FAST motors
- \* with drive max current limited
  - with 0.25 mH choke in series for each motor phase
  - ▼ with 1.5 mH choke in series for each motor phase

The nominal torque, continuous duty,  $\Delta\theta$  win = 110°C and the peak torque are not always achievable with the recommended drive.

**460Vac**  
 Please contact our appointed Service Centers for max torque at nominal speed with DBS/DBM04, DS2000 and  $\mu$ DS drives

**NOTE GENERALI ALLE TABELLE DEI DATI TECNICI**

**M**= servomotori serie FAS T/F da utilizzare con azionamenti DS2000 e  $\mu$ DS a 230 Vac  
**V**= servomotori serie FAS T/F da utilizzare con azionamenti DBS/DBM04, DS2000 e  $\mu$ DS a 400/460 Vac

- ambiente a 20°C e flangia a 45°C
- vedi "Caratteristica Coppia/Velocità"
- per i motori FASF la corrente nominale è riferita a Tn110 e, per i motori FAST, a Tn65
- \* con limitazione della corrente massima dell'azionamento
  - con induttanza da 0.25 mH in serie per fase motore
  - ▼ con induttanza da 1.5 mH in serie per fase motore

La coppia nominale in servizio continuo a rotore bloccato con  $\Delta\theta$  avv = 110°C e la coppia di picco non sempre sono compatibili con l'azionamento consigliato.

**460Vac**  
 Consultare i Service Centers riguardo la coppia massima alla velocità nominale con azionamenti DBS/DBM04, DS2000 e  $\mu$ DS.

**RESOLVERS**

VERSION	Model	Poles	Power Supply	Frequency	Max Current	Max Error Spread	Phase Shift	Zro  Input Imp.	Zss  Output Imp.	$\tau$ Transf. Ratio
VERSIONE	Modello	Poli	Tensione Alimentazione	Frequenza	Corrente Max	Errore Max Picco-Picco	Sfasamento	Zro  Imped.Ingresso	Zss  Imped.Uscita	$\tau$ Rapp. Trasf.
		(n°)	(Vrms)	(kHz)	(mArms)	(min)	(°)	( $\Omega$ )	( $\Omega$ )	
Standard	T00	6	7.1	10	25	10	0±5	≥280	≤850	0.50 +5% -10%
	T0, T/F1-2-3	6	7.1	10	15	10	0-6	≥470	≤850	0.29 +5% -10%
	T/F4	8	7.1	10	15	16	0-6	≥470	≤850	0.29 +5% -10%
Optional Opzionale	T00	2	7.1	10	25	10	0-6	≥280	≤850	0.47 +5% -10%
	T0, T/F1-2-3-4	2	7.1	10	25	20	0-6	≥280	≤850	0.47 +5% -10%
	T0, T/F1-2-3	6	7.1	10	15	4	0-6	≥470	≤850	0.29 +5% -10%

Note: 2 pole resolver is standard for  $\omega > 8000$  rpm with  $\mu$ DS, DBM04 and DS2000 drives  
 Nota: il resolver a 2 poli è standard per  $\omega > 8000$  r/min con gli azionamenti  $\mu$ DS, DBM04 e DS2000

**ELECTRICAL OPTIONS / OPZIONI ELETTRICHE**

**Safety Brake / Freno di stazionamento**

(Not available for T00 / Non disponibile per T00)

**FAS T0**

Screw plug PG7  
Foro filettato PG7

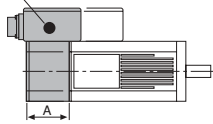

**FAS T1/F1, T2/F2**

Screw plug PG7  
Foro filettato PG7

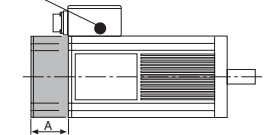

<b>BRAKE CHARACTERISTICS CARATTERISTICHE FRENI</b>	<b>FAS</b>	<b>T0</b>	<b>T1</b>	<b>F1</b>	<b>T2</b>	<b>F2</b>	<b>T3</b>	<b>F3</b>	<b>T4</b>	<b>F4</b>	<b>Unit Unità</b>
Supply Voltage <i>Tensione Alimentazione</i>		24	24	24	24	24	24	24	24	24	Vdc
Supply Current <i>Corrente Assorbita</i>		0.5	0.75	0.75	1.75	1.75	2.3	2.3	2.3	2.3	A
Stating brake holding torque <i>Coppia frenante statica</i>		2.2	9	9	30	30	90	90	90	90	Nm
Inertia <i>Momento d'inerzia</i>		17	50	50	446	446	2300	2300	2300	2300	10 <sup>-6</sup> kgm <sup>2</sup>
Weight <i>Massa</i>		1	1.8	2	5	6.3	12.3	14	15	17	kg
Max angular backlash <i>Gioco angolare massimo</i>		20	20	20	20	20	20	20	20	20	arcmin
Length [A] <i>Lunghezza [A]</i>		53	49	49	59	59	64	70	85	90	mm

For FAS T3/F3 and T4/F4 the screw plug is just for type B connector box. Brake supplied by connector for Type C connection

Per FAS T3/F3 e T4/F4 il foro è presente solo per cassette tipo B. Nei casi di cassetto Tipo C il freno è alimentato tramite connettore.

**Caution:**

to ensure a proper brake release we recommend 24÷26 Vdc supply measured at motor terminals. Brake must be clamped and released with motor at standstill.

**Attenzione:**

per garantire un corretto sgancio del freno raccomandiamo una tensione di 24÷26 Vdc misurata ai terminali del motore. Il freno deve essere inserito e disinserito a rotore fermo.

**Optical encoder mounting kit / Predisposizione per encoder ottico**

(not available for T00, T4 and fan cooled motors / non disponibile per T00, T4 e motori ventilati)

Note (type B only): for FAS T0 motors the fixing holes are  $\varnothing 4,5$  on  $\varnothing 42 \pm 0,1$

Nota (solo per il Tipo B): per i motori FAS T0 i fori sono  $\varnothing 4,5$  su  $\varnothing 42 \pm 0,1$

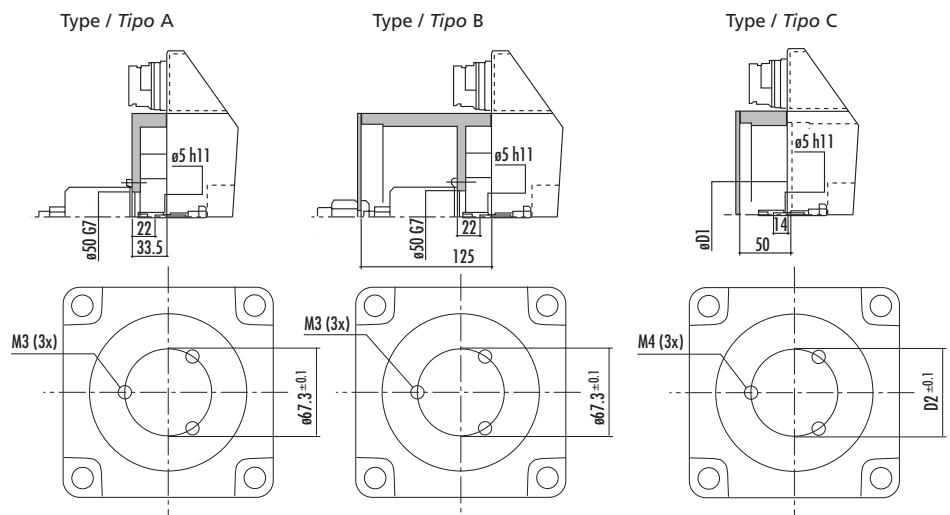

<b>MOUNTING KIT TYPE TIPO PREDISP. ENCODER</b>		<b>T0</b>	<b>T1</b>	<b>T2</b>	<b>T3</b>	<b>Unit Unità</b>
<b>Weight Massa</b>	A	0.2	0.4	1	2	kg
	B	0.8	1.1	2	4.5	kg
	C	0.4	0.7	1.5	3.2	kg
	D1	35	35	60	60	mm
	D2	55	55	75	75	mm

**MECHANICAL OPTIONS / OPZIONI MECCANICHE**

**B14 Flange / Flangia B14**

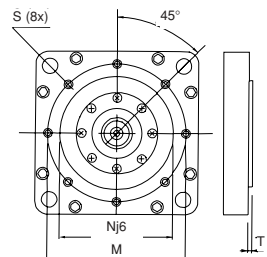

TYPE TIPO	T/F1	T/F2	T/F3	T/F4
N	70	95	130	180
M	85	115	165	215
T	2.5	3	3.5	4
S	M6x9	M8x12	M10x15	M12x15

**Shaft with key / Albero con chiavetta**

[according IEC 72-1 (1991) / secondo le norme IEC 72-1 (1991) ]

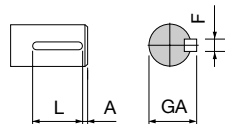

TYPE TIPO	T00	T0	T/F1	T/F2	T/F3 M-V2-3	T/F3 M-V4-6-8	T/F4
L	14	20	25	32	40	70	75
A	3	3	3	3	4	5	5
GA	10.2	16	21.5	27	35	45	59
F	3	5	6	8	10	12	16

**Eccentricity / Eccentricità**

[according IEC 72-1 (1991) / secondo le norme IEC 72-1 (1991) ]

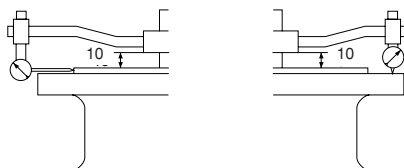

TYPE TIPO	T00	T0	T/F1	T/F2	T/F3	T/F4
Standard Tolerance <i>Tolleranza Standard</i>	0.080	0.080	0.080	0.100	0.100	0.125
Reduced Tolerance <i>Toll.Grado Preciso</i>	0.040	0.040	0.040	0.050	0.050	0.063

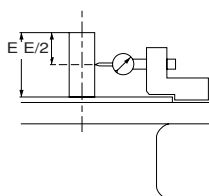

TYPE TIPO	T00	T0	T/F1	T/F2	T/F3	T/F4
Standard Tolerance <i>Tolleranza Standard</i>	0.030	0.035	0.040	0.040	0.050	0.060
Reduced Tolerance <i>Toll.Grado Preciso</i>	0.015	0.018	0.021	0.021	0.025	0.030

**Standard / Standard**

**T00 motors**

All T00 motors have connection leads length = 200 mm, section 0.24 mm<sup>2</sup> for signal cable and 0.61 mm<sup>2</sup> for power cable.

**Motori T00**

Tutti i motori T00 sono forniti esclusivamente con cavi volanti, lunghezza 200 mm, sezione 0.24 mm<sup>2</sup> per cavo segnali e 0.61 mm<sup>2</sup> per cavo potenza.

Power connection\* / Conessioni motore\*

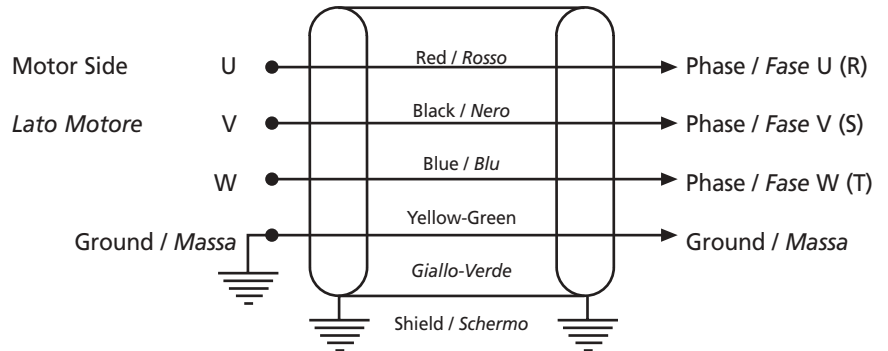

Signal cable\* / Cavo segnali\*

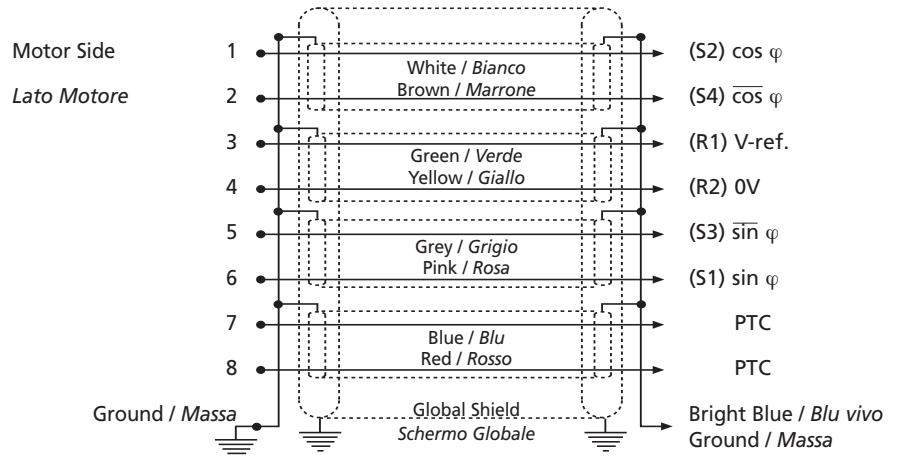

(\*) Grounding of shield via connector clamp

(\*) Collegamento a massa della calza tramite custodia connettore

Connection Box Dimension (mm) / Dimensioni Scatola Conessioni (mm) (not available for T00 / non disponibile per T00)		
Type A / Tipo A	Type B / Tipo B	Type C / Tipo C
75 x 75 x 43	100 x 100 x 60	140 x 124 x 80

**Signal connector**

(for all FAS T/F, except IP67 option and T00)  
PT 00E 14-19 PC-10, PT06F 8AG 14-19S

**Connettore segnali**

(vale per tutti i FAS T/F, tranne per opzione IP67 e T00)  
PT 00E 14-19 PC-10, PT06F 8AG 14-19S

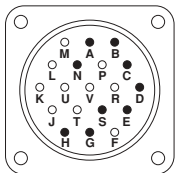

- Resolver
- C (S2)  $\cos \varphi$
- E (S4)  $\overline{\cos \varphi}$
- D (R1) V-ref
- B (R2) 0V
- N PTC
- A PTC
- G (S1)  $\sin \varphi$
- H (S3)  $\overline{\sin \varphi}$
- S shield / schermo

**Power terminal board - Type B box**

**Morsettiera potenza - Scatola Tipo B**

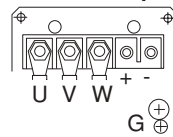

- U Phase / Fase U
- V Phase / Fase V
- W Phase / Fase W
- G Ground / Massa
- + Brake / Freno
- Brake / Freno

**Power terminal board - Type A box**

**Morsettiera potenza - Scatola Tipo A**

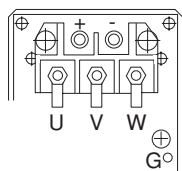

- U Phase / Fase U
- V Phase / Fase V
- W Phase / Fase W
- G Ground / Massa
- + Brake / Freno
- Brake / Freno

**Power terminal board - Type C box**

**Morsettiera potenza - Scatola Tipo C**

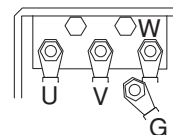

- U Phase / Fase U
- V Phase / Fase V
- W Phase / Fase W
- G Ground / Massa

**Options / Opzionali**

**Power and brake connectors / Connettori potenza e freno**

(not available for FAS T00 / non disponibile per FAS T00)

Power connector - **Type A** box  
 Connettore potenza - scatola **Tipo A**  
 PT 00E 16-8 PC-2, PT06F8 AG 16-8S

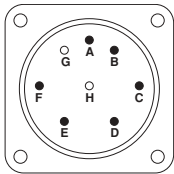

- A** Phase U / Fase U
- B** Phase V / Fase V
- C** Phase W / Fase W
- D** Ground / Massa
- E** Brake + / Freno +
- F** Brake - / Freno -

Power connector - **Type B** box  
 Connettore potenza - scatola **Tipo B**  
 97B 3100RS 24-10P, 97B3106F 24-10S

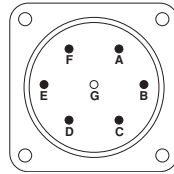

- A** Phase U / Fase U
- B** Phase V / Fase V
- C** Phase W / Fase W
- D** Ground / Massa
- E** Brake + / Freno +
- F** Brake - / Freno -

Power connector - **Type C** box  
 Connettore potenza - scatola **Tipo C**  
 97B 3102R 36-5P, 97B3106F 36-5S

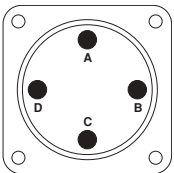

- A** Phase U / Fase U
- B** Phase V / Fase V
- C** Phase W / Fase W
- D** Ground / Massa

**Brake connector** (option for motors with type C box)  
**Connettore freno** (solo per motori con scatola tipo C)  
 PT 00E 8-3PC, PT06F 8AG3S

(see note page 25)  
 (vedere nota a pag. 25)

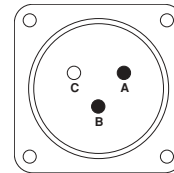

- A** Brake + / Freno +
- B** Brake - / Freno -

**IP67 version signal connector (\*)**  
**Connettore segnale versione IP67 (\*)**  
 (only for IP67 protection / solo per protezione IP67)  
 AMPMODU II 280637, AMPMODU II 280365

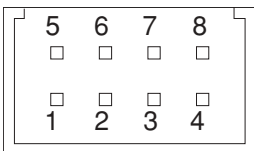

- 1 (S2)  $\cos \varphi$
- 2 (S4)  $\overline{\cos \varphi}$
- 3 (R1) V-ref
- 4 (R2) OV
- 5 (S1)  $\sin \varphi$
- 6 (S3)  $\overline{\sin \varphi}$
- 7 PTC
- 8 PTC

**Fan connector**  
**Connettore ventilatore**  
 (for FAS F3 and FAS F4 motors; FAS F1 and F2 connection by faston 2.8x0.5 / solo per motori FAS F3 e FAS F4; motori FAS F1 e F2 connessione tramite faston 2.8x0.5)  
 PT 00E 14-5 PC1, PT 06F8AG 14-5 S

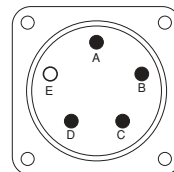

- A** Phase U / Fase U
- B** Phase V / Fase V
- C** Phase W / Fase W
- D** Ground / Massa

(\*) Note: not available for T00 and FAS F. Plug connector, contacts and cable clamps can be ordered separately. The optional power connector is incompatible with the IP67 protection. To rotate the connector box, gaskets must be changed

(\*) Nota: non disponibile per T00 e FAS F. Parte volante connettore, contatti e pressacavi ordinabili separatamente. Il connettore di potenza opzionale è incompatibile con la protezione IP67 - La scatola connessioni può essere ruotata a condizione di sostituire le guarnizioni.

**Model Code / Codifica**

**FAS T** -    -    -    -    -    -    -    -   

Size/Taglia  
00  
01  
02  
03  
04

Standard Motor  
Motore Standard -  
Motor according to UL-CSA  
Motore omologato UL-CSA **U**

Version/Versione  
Number of rotor modules  
Numero dei moduli rotore

Nominal Speed rpm/100  
Velocità nominale r/min/100

Electrical Options  
Opzioni elettriche

Mechanical Options  
Opzioni meccaniche

Special Version  
Versione Speciale

	6 pole resolver, 180V winding (230V main supply) <i>Resolver 6 poli, avvolgimento 180V, (alim. 230V)</i>	2 pole resolver, 180V winding (230V main supply) <i>Resolver 2 poli, avvolgimento 180V (alim. 230V)</i>	6 pole resolver, 4 arcmin resolver, 180V winding, (230V main supply) <i>Resolver 6 poli, resolver 4 arcmin avvolgimento 180V (alim. 230V)</i>	6 pole resolver, 325/375V winding (400/460 main supply) <i>Resolver 6 poli, avvolgimento 325/375V, (alim. 400/460V)</i>	2 pole resolver, 325/375V winding (400/460V main supply) <i>Resolver 2 poli, avvolgimento 325/375V (alim. 400/460V)</i>	6 pole resolver, 4 arcmin resolver, 325/375V winding, (400/460V main supply) <i>Resolver 6 poli, resolver 4 arcmin avvolgimento 325/375V (alim. 400/460V)</i>
	<b>M</b>	<b>A</b>	<b>L</b>	<b>V</b>	<b>C</b>	<b>S</b>
01						
02						
03						
04						
05						
06						
10						
11						
12						
13						
14						
15						
16						
17						
18						
19						
20						
21						
22						
23						
24						
25						
26						
27						
28						
29						
30						

	Safety Brake Freno stazionamento	Optical Encoder Preparation Encoder Ottico	Encoder Equipped Encoder fornito	Power Connector Connettore Potenza	Flange B14	IP65 Protection Protezione IP65	Key IEC72 Chiavetta IEC72	Reduced Tolerance Tolleranza ridotta	Shaft exit seal Guarnizione uscita albero	IP67 Protection Protezione IP67
01										
02										
03										
04										
05										
06										
10										
11										
12										
13										
14										
15										
16										
17										
18										
19										
20										
21										
22										
23										
24										
25										
26										
27										
28										
29										
30										

**Notes:**

- L/S version motors are not available for 00 and 4 size.
- Size 4 motors, M and V version, are equipped with 8 pole resolver.
- Motors to be assembled on gear box must have reduced tolerance and shaft exit seal.
- If "equipped" the type of encoder is indicated in the last two digits of motor code "Special Version".
- IP protection is referred to the motor (Standard IP64).
- Power connector is not available with IP67 protection

**Note:**

- I motori versione LIS non sono disponibili nelle taglie 00 e 4.
- I motori versione M e V taglia 4 montano resolver 8 poli.
- I motori che devono essere accoppiati a riduttori debbono avere tolleranza ridotta e guarnizione uscita albero.
- Se il motore è equipaggiato con encoder, il tipo di encoder è indicato nelle ultime due cifre della "Versione Speciale"
- La protezione IP è riferita al motore (Standard IP64)
- Il connettore di potenza non è disponibile con la protezione IP67

## Model Code / Codifica

**FAS F** -    -    -    -    -    -    -    -   

Size/Taglia 1  
2  
3  
4

Version/Versione  
Number of rotor modules  
Numero dei moduli rotore

Nominal Speed rpm/100  
Velocità nominale r/min/100

Electrical Options  
Opzioni elettriche

Mechanical Options  
Opzioni meccaniche

Special Version  
Versione Speciale

Standard Motor  
Motore Standard -  
Motor according to UL-CSA  
Motore omologato UL-CSA **U**

6 pole resolver, 180V winding (230 main supply) <i>Resolver 6 poli, avvolgimento 180V, (alim. 230V)</i> <b>M</b>	Safety Brake Freno stazionamento Power Connector Connettore Potenza	<table border="1"> <tr><td>10</td><td></td><td></td></tr> <tr><td>17</td><td></td><td></td></tr> <tr><td>24</td><td></td><td></td></tr> </table>	10			17			24			<table border="1"> <tr><td>01</td><td></td><td></td><td></td><td></td><td></td></tr> <tr><td>02</td><td></td><td></td><td></td><td></td><td></td></tr> <tr><td>03</td><td></td><td></td><td></td><td></td><td></td></tr> <tr><td>04</td><td></td><td></td><td></td><td></td><td></td></tr> <tr><td>05</td><td></td><td></td><td></td><td></td><td></td></tr> <tr><td>06</td><td></td><td></td><td></td><td></td><td></td></tr> <tr><td>07</td><td></td><td></td><td></td><td></td><td></td></tr> <tr><td>08</td><td></td><td></td><td></td><td></td><td></td></tr> <tr><td>09</td><td></td><td></td><td></td><td></td><td></td></tr> <tr><td>10</td><td></td><td></td><td></td><td></td><td></td></tr> <tr><td>11</td><td></td><td></td><td></td><td></td><td></td></tr> <tr><td>12</td><td></td><td></td><td></td><td></td><td></td></tr> <tr><td>13</td><td></td><td></td><td></td><td></td><td></td></tr> <tr><td>14</td><td></td><td></td><td></td><td></td><td></td></tr> <tr><td>15</td><td></td><td></td><td></td><td></td><td></td></tr> <tr><td>16</td><td></td><td></td><td></td><td></td><td></td></tr> <tr><td>17</td><td></td><td></td><td></td><td></td><td></td></tr> <tr><td>18</td><td></td><td></td><td></td><td></td><td></td></tr> <tr><td>19</td><td></td><td></td><td></td><td></td><td></td></tr> <tr><td>20</td><td></td><td></td><td></td><td></td><td></td></tr> <tr><td>21</td><td></td><td></td><td></td><td></td><td></td></tr> <tr><td>22</td><td></td><td></td><td></td><td></td><td></td></tr> <tr><td>23</td><td></td><td></td><td></td><td></td><td></td></tr> <tr><td>24</td><td></td><td></td><td></td><td></td><td></td></tr> <tr><td>25</td><td></td><td></td><td></td><td></td><td></td></tr> <tr><td>26</td><td></td><td></td><td></td><td></td><td></td></tr> <tr><td>27</td><td></td><td></td><td></td><td></td><td></td></tr> <tr><td>28</td><td></td><td></td><td></td><td></td><td></td></tr> <tr><td>29</td><td></td><td></td><td></td><td></td><td></td></tr> <tr><td>30</td><td></td><td></td><td></td><td></td><td></td></tr> <tr><td>31</td><td></td><td></td><td></td><td></td><td></td></tr> </table>	01						02						03						04						05						06						07						08						09						10						11						12						13						14						15						16						17						18						19						20						21						22						23						24						25						26						27						28						29						30						31					
10																																																																																																																																																																																																						
17																																																																																																																																																																																																						
24																																																																																																																																																																																																						
01																																																																																																																																																																																																						
02																																																																																																																																																																																																						
03																																																																																																																																																																																																						
04																																																																																																																																																																																																						
05																																																																																																																																																																																																						
06																																																																																																																																																																																																						
07																																																																																																																																																																																																						
08																																																																																																																																																																																																						
09																																																																																																																																																																																																						
10																																																																																																																																																																																																						
11																																																																																																																																																																																																						
12																																																																																																																																																																																																						
13																																																																																																																																																																																																						
14																																																																																																																																																																																																						
15																																																																																																																																																																																																						
16																																																																																																																																																																																																						
17																																																																																																																																																																																																						
18																																																																																																																																																																																																						
19																																																																																																																																																																																																						
20																																																																																																																																																																																																						
21																																																																																																																																																																																																						
22																																																																																																																																																																																																						
23																																																																																																																																																																																																						
24																																																																																																																																																																																																						
25																																																																																																																																																																																																						
26																																																																																																																																																																																																						
27																																																																																																																																																																																																						
28																																																																																																																																																																																																						
29																																																																																																																																																																																																						
30																																																																																																																																																																																																						
31																																																																																																																																																																																																						
2 pole resolver, 180V winding (230V main supply) <i>Resolver 2 poli, avvolgimento 180V (alim. 230V)</i> <b>A</b>																																																																																																																																																																																																						
6 pole resolver, 4 arcmin resolver, 180V winding (230V main supply) <i>Resolver 6 poli, resolver 4 arcmin. avvolgimento 180V (alim. 230V)</i> <b>L</b>																																																																																																																																																																																																						
6 pole resolver, 325/375V winding (400/460 main supply) <i>Resolver 6 poli, avvolgimento 325/375V, (alim. 400/460V)</i> <b>V</b>																																																																																																																																																																																																						
2 pole resolver, 325/375V winding (400/460V main supply) <i>Resolver 2 poli, avvolgimento 325/375V (alim. 400/460V)</i> <b>C</b>																																																																																																																																																																																																						
6 pole resolver, 4 arcmin resolver, 325/375V winding (400/460V main supply) <i>Resolver 6 poli, resolver 4 arcmin avvolgimento 325/375V (alim. 400/460V)</i> <b>S</b>																																																																																																																																																																																																						

Flange B14  
Flangia B14

IP65 Protection  
Protezione IP65

Key IEC72  
Chiavetta IEC72

Reduced Tolerance  
Tolleranza ridotta

Shaft exit seal  
Guarnizione uscita albero

Notes:

- L/S version motors are not available for size 4.
- Size 4 motors, M and V version, are equipped with 8 pole resolver.
- Motors to be assembled on gear box must have reduced tolerance and shaft exit seal.
- IP protection is referred to the motor (Standard IP64).

Note:

- I motori versione L/S non sono disponibili nella taglia 4.
- I motori versione M e V taglia 4 montano resolver 8 poli.
- I motori che devono essere accoppiati a riduttori debbono avere tolleranza ridotta e guarnizione uscita albero.
- La protezione IP è riferita al motore (Standard IP64)

Code Example / Esempio di Codifica

**FAS T - 2 - M4 - 030 - 12 - 33 - 00**

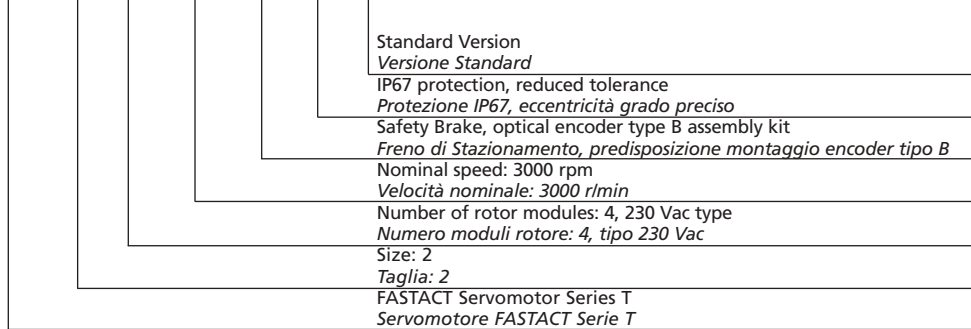

**FAS F - 3UV6 - 030 - 17 - 01 - 00**

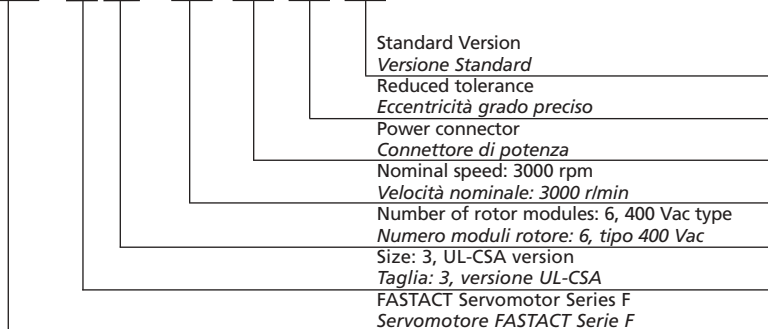





**Argentina  
Australia  
Austria  
Brazil  
China  
Finland  
France  
Germany  
India  
Ireland**



**Italy  
Japan  
Korea  
Luxembourg  
Norway  
Russia  
Singapore  
South Africa  
Spain  
Sweden  
United Kingdom  
USA**

# MOOG

**COMPANY WITH INTEGRATED  
MANAGEMENT SYSTEM  
CERTIFIED BY DNV  
=ISO 9001/ISO 14001=**

Moog Italiana S.r.l.  
Electric Division  
Via Avosso, 94-16015 Casella (Genova) - Italy  
Telephone: (+39) 010 96711  
Fax: (+39) 010 9671280  
For the location nearest to you, contact  
[www.moog.com/worldwide](http://www.moog.com/worldwide)

Fastact T/F CAS-008 EN/IT 0703