

ACCU ELECTRIC MOTORS INC

USA: (888) 932-9183

CANADA: (905) 829-2505

- ✓ Over 100 years cumulative experience
- ✓ 24 hour rush turnaround / technical support service
- ✓ Established in 1993



The leading independent repairer of servo motors and drives in North America.

Visit us on the web:

www.servo-repair.com

www.servorepair.ca

www.ferrocontrol.com

www.sandvikrepair.com

www.accuelectric.com

Scroll down to view your document!

For 24/7 repair services :

USA: 1 (888) 932 - 9183

Canada: 1 (905) 829 -2505

Emergency After hours: 1 (416) 624 0386

Servicing USA and Canada

Incremental Rotary Encoder E6C2-C

<READ AND UNDERSTAND THIS CATALOG>

Please read and understand this catalog before purchasing the products. Please consult your OMRON representative if you have any questions or comments.

IP64 Drip-proof Construction

The E6C2-C incorporates a rubber-seal bearing cover of IP64 drip-proof construction thus ensuring ease of use in places with water dripping or sprayed oil.



Shaft Withstands Heavy Loads

The bearing used by the E6C2-C is larger than that of the conventional E6C-C, thus withstanding heavier loads.

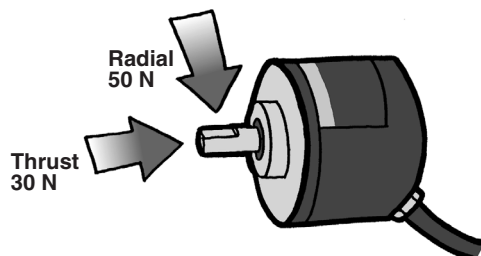

Protective Circuit for Output Shorting

The E6C2-C incorporates a circuit protecting the E6C2-C from damage resulting from the incorrect wiring of output, thus ensuring ease of use.



33% Smaller than E6C-C

The E6C2-C uses a high-performance LED indicator, custom-made receiver element, high-density PCB, and seal bearing thus making the E6C2-C 33% smaller than the conventional E6C-C.

Conventional Model

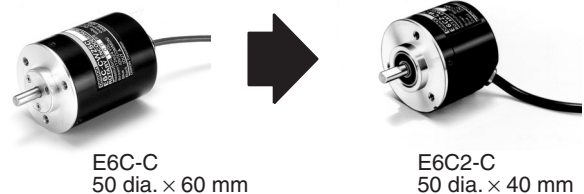

Incorporating Cord to Be Pulled Out Aslant Ensuring Ease of Mounting and Wiring

To suit the mounting position, it was necessary to select a conventional E6C-C model with a cord that is pulled out horizontally or a model with a cord that is pulled out backwards. The E6C2-C incorporates a cord that is pulled out aslant, thus ensuring ease of mounting and wiring while saving mounting space.

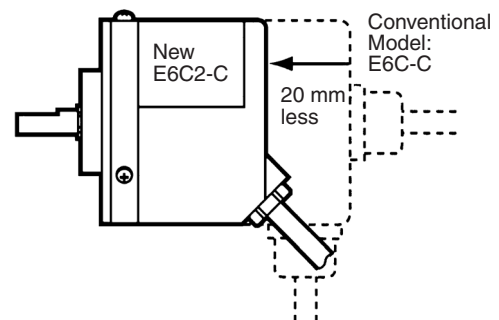

Ordering Information

Supply voltage	Output configuration	Resolution (P/R)	Model
5 to 24 VDC	NPN open collector output	10, 20, 30, 40, 50, 60, 100, 200, 300, 360, 400, 500, 600	E6C2-CWZ6C
		720, 800, 1,000, 1,024, 1,200, 1,500, 1,800, 2,000	
12 to 24 VDC	PNP open collector output	100, 200, 360, 500, 600	E6C2-CWZ5B
		1,000, 2,000	
5 to 12 VDC	Voltage output	10, 20, 30, 40, 50, 60, 100, 200, 300, 360, 400, 500, 600	E6C2-CWZ3E
		720, 800, 1,000, 1,024, 1,200, 1,500, 1,800, 2,000	
5 VDC	Line driver output	10, 20, 30, 40, 50, 60, 100, 200, 300, 360, 400, 500, 600	E6C2-CWZ1X
		720, 800, 1,000, 1,024, 1,200, 1,500, 1,800, 2,000	

Note: When ordering, specify the resolution in addition to the model numbers.

■ Accessories (Order Separately)

Name	Model	Remarks
Coupling	E69-C06B	---
	E69-C68B	Incorporates ends different to each other in diameter.
	E69-C06M	Metal construction.
Flange	E69-FCA	---
	E69-FCA02	
Servo Mounting Bracket	E69-2	Provided with the E69-FCA02 Flange.

Application Examples

Filler Control

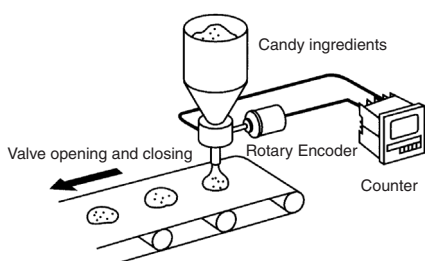

Positioning of Wafer Cutting Machine

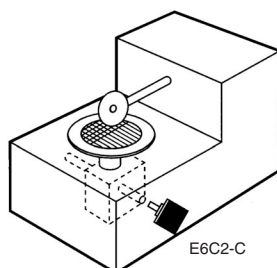

Metal Mold Positioning of Injection Molding Machine

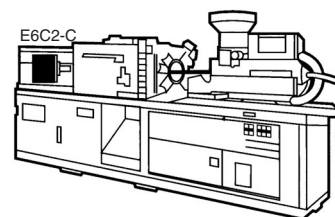

Specifications

■ Ratings/Characteristics

Item	E6C2-CWZ6C	E6C2-CWZ5B	E6C2-CWZ3E	E6C2-CWZ1X
Power supply voltage	5 VDC -5% to 24 VDC +15%	12 VDC -10% to 24 VDC +15%	5 VDC -5% to 12 VDC +10%	5 VDC±5%
Current consumption (see note 1)	80 mA max.	100 mA max.		160 mA max.
Resolution	10, 20, 30, 40, 50, 60, 100, 200, 300, 360, 400, 500, 600, 720, 800, 1,000, 1,024, 1,200, 1,500, 1,800, 2,000 P/R	100, 200, 360, 500, 600, 1,000, 2,000 P/R	10, 20, 30, 40, 50, 60, 100, 200, 300, 360, 400, 500, 600, 720, 800, 1,000, 1,024, 1,200, 1,500, 1,800, 2,000 P/R	
Output phases	A, B, and Z (reversible)			A, \bar{A} , B, \bar{B} , Z, \bar{Z}
Output configuration	NPN open collector output	PNP open collector output	Voltage output (NPN output)	Line driver output (see note 2)
Output capacity	Applied voltage: 30 VDC max. Output current: 35 mA max. Residual voltage: 0.4 V max. (at sink current of 35 mA)	Output current: 35 mA max. Residual voltage: 0.4 V max. (at sink current of 35 mA)	Output resistance: 2 k Ω Output current: 20 mA max. Residual voltage: 0.4 V max. (at sink current of 20 mA)	AM26LS31 equivalent Output current: High level (I_o): -20 mA Low level (I_s): 20 mA Output voltage: V_o : 2.5 V min. V_s : 0.5 V max.
Max. response frequency (see note 3)	100 kHz	50 kHz	100 kHz	
Phase difference on output	90°±45° between A and B (1/4T±1/8T)			
Rise and fall times of output	1 μ s max. (control output voltage: 5 V; load resistance: 1 k Ω ; cable length: 2 m)	1 μ s max. (cable length: 2 m; I_{sink} : 10 mA)		0.1 μ s max. (cable length: 2 m; I_o : -20 mA; I_s : 20 mA)
Starting torque	10 m N·m max.			
Moment of inertia	1 x 10 ⁻⁶ kg·m ² max.; 3 x 10 ⁻⁷ kg·m ² max. at 600 P/R max.			
Shaft loading	Radial: 50 N Thrust: 30 N			
Max. permissible revolution	6,000 rpm			
Protection circuits	Reversed power supply connection protection circuit, output load short-circuit protection circuit			---
Ambient temperature	Operating: -10°C to 70°C (with no icing) Storage: -25°C to 85°C (with no icing)			
Ambient humidity	Operating: 35% to 85% (with no condensation)			
Insulation resistance	20 M Ω min. (at 500 VDC) between current carry parts and case			
Dielectric strength	500 VAC, 50/60 Hz for 1 min between current carry parts and case			
Vibration resistance	Destruction: 10 to 500 Hz, 150 m/s ² or 2-mm double amplitude for 11 min 3 times each in X, Y, and Z directions			
Shock resistance	Destruction: 1,000 m/s ² (100G) 3 times each in X, Y, and Z directions			
Degree of protection	IEC60529 IP64			
Connection method	Pre-wired (standard length: 2 m)			
Weight	Approx. 400 g			
Others	Instruction manual			

Note: 1. An inrush current of approx. 9 A flows for approx. 0.3 ms right after the E6C2-C is turned on.

- The line driver output of the E6C2-C is used for data transmission circuitry conforming to RS-422A and ensures long-distance transmission over twisted-pair cable, the quality of which is equivalent to AM26LS31.
- The maximum electrical response revolution is determined by the resolution and maximum response frequency as follows:
Maximum electrical response frequency (rpm) = Maximum response frequency/resolution × 60
This means that the E6C2-C Rotary Encoder will not operate electrically if its revolution exceeds the maximum electrical response revolution.

4. Origin Indication

It is easy to adjust the position of phase Z with the origin indication function. The following illustration (on the left side) shows the relationship between phase Z and the origin. Set cut face D to the origin as shown in the illustration (on the right side).

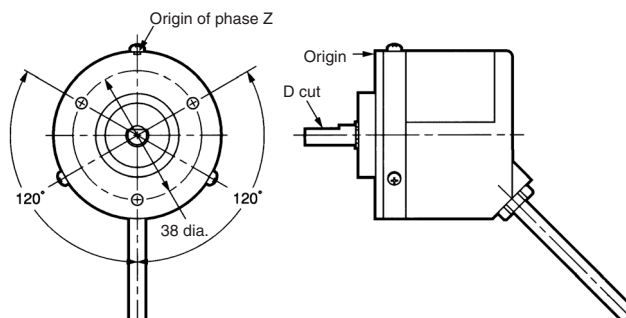

Operation

Output Circuit Diagram

E6C2-CWZ6C

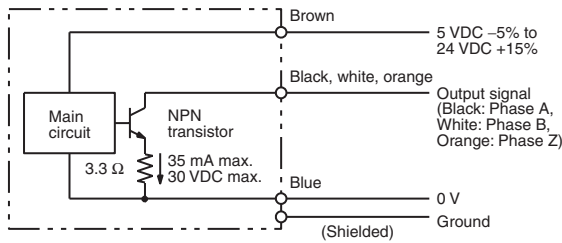

E6C2-CWZ3E

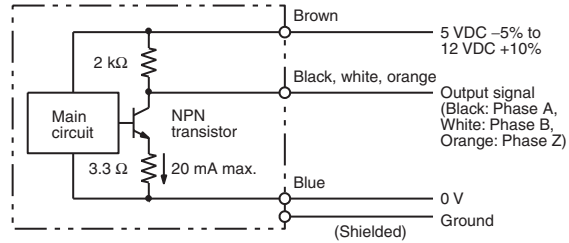

E6C2-CWZ1X

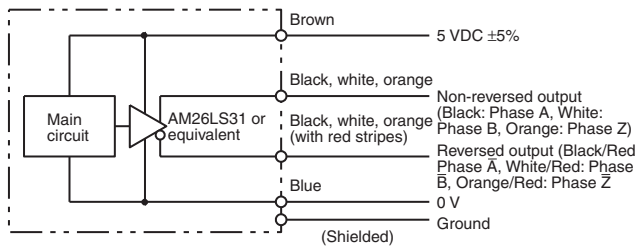

E6C2-CWZ5B

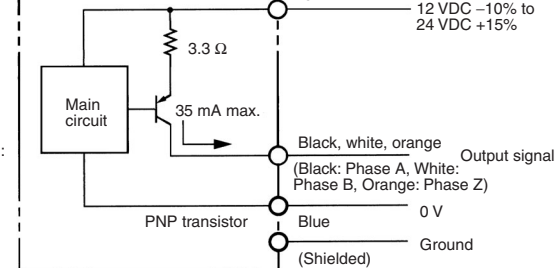

- Note:**
1. The shield is not connected to the internal circuits or casing of the E6C2-C.
 2. There is no difference in circuit among phases A, B, and Z.
 3. Connect the GND terminal to 0 V or the ground when the E6C2-C is in normal operation.

Timing Charts

NPN Open Collector Output

E6C2-CWZ6C

PNP Open Collector Output

E6C2-CWZ5B

Direction or resolution: Clockwise (CW)
(As viewed from the end of the shaft)

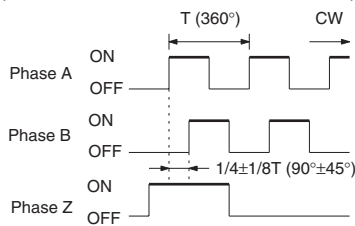

Note: Phase A is $1/4 \pm 1/8 T$ faster than phase B. The ONs in the above timing chart mean that the output transistor is ON and the OFFs mean that the output transistor is OFF.

Direction or resolution: Counterclockwise (CCW)
(As viewed from the end of the shaft)

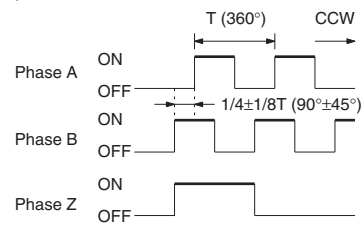

Note: Phase A is $1/4 \pm 1/8 T$ slower than phase B.

Voltage Output

E6C2-CWZ3E

Direction or resolution: Clockwise (CW)
(As viewed from the end of the shaft)

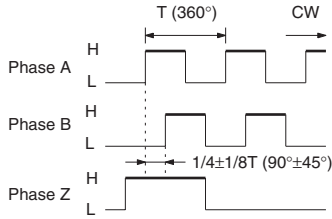

Note: Phase A is 1/4 ± 1/8T faster than phase B.

Direction or resolution: Counterclockwise (CCW)
(As viewed from the end of the shaft)

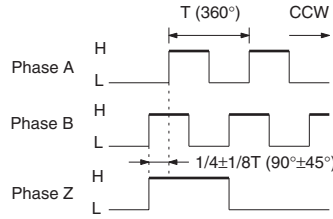

Note: Phase A is 1/4 ± 1/8T slower than phase B.

Line Driver Output

E6C2-CWZ1X

Direction or resolution: Clockwise (CW)
(As viewed from the end of the shaft)

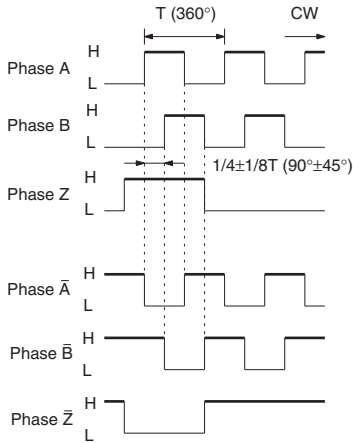

Direction or resolution: Counterclockwise (CCW)
(As viewed from the end of the shaft)

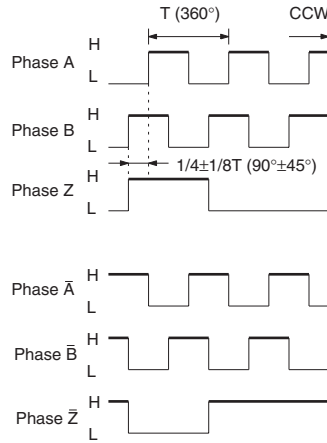

Input to More than One Counter from Encoder (with Voltage Output)

Use the following formula to obtain the number of counters to be connected to a single E6C2-C Rotary Encoder.

$$\text{Number of counters (N)} = \frac{R1 (E-V)}{V \times R2}$$

- E: Voltage supplied to Rotary Encoder
- V: Minimum input voltage of the counter
- R2: Output resistance of the Rotary Encoder
- R1: Input resistance of the Counter

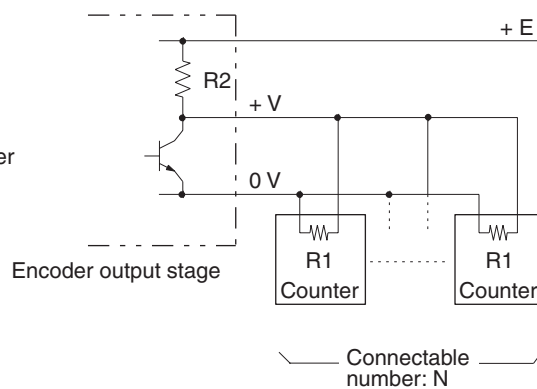

Dimensions

Note: All units are in millimeters unless otherwise indicated.

E6C2-CWZ□□

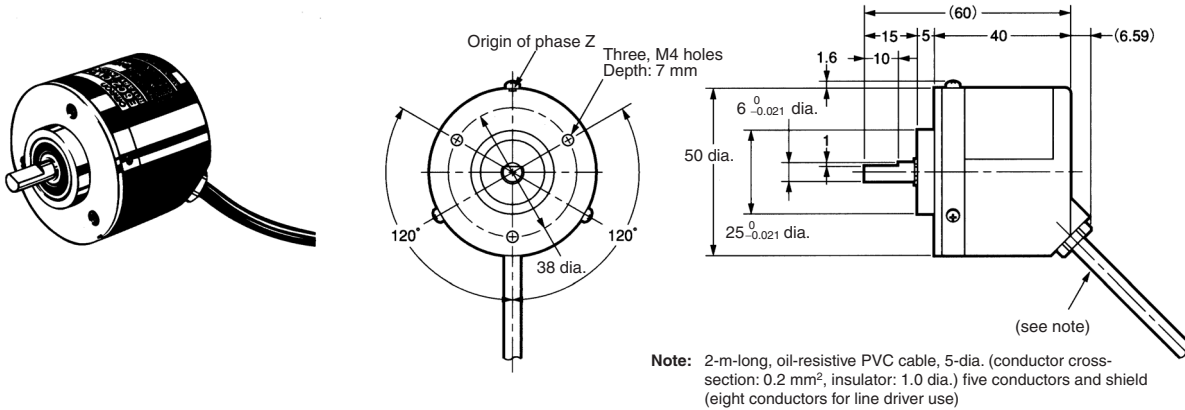

■ Accessories (Order Separately)

Couplings

E69-C06B

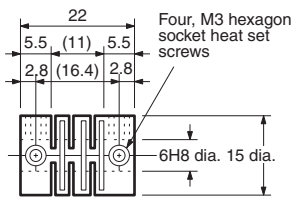

Note: The coupling is made of glass-reinforced PBT.

E69-C68B
(With Ends of Different Diameter)

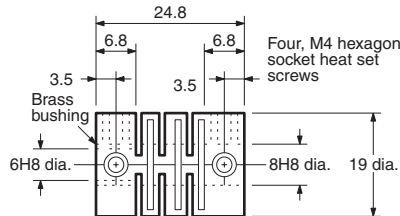

Note: The coupling is made of glass-reinforced PBT.

E69-C06M (Metal Construction)

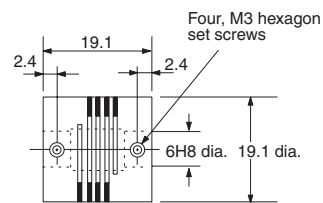

Note: Material: Super duralumin

Flanges

E69-FCA

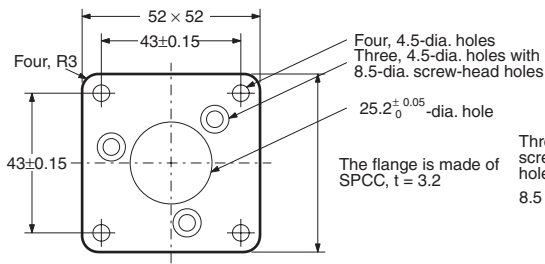

E69-FCA02

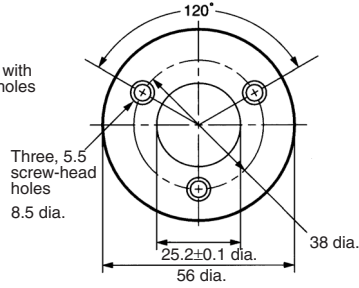

Note: Material: SPCC, t=3.2

Mounting Bracket: (A set of three Brackets provided with the E69-FCA02)

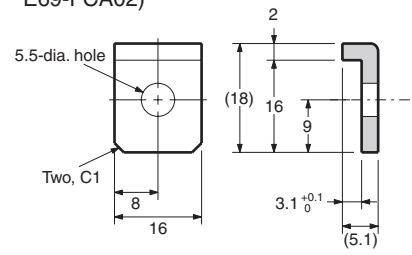

Mounting Dimensions

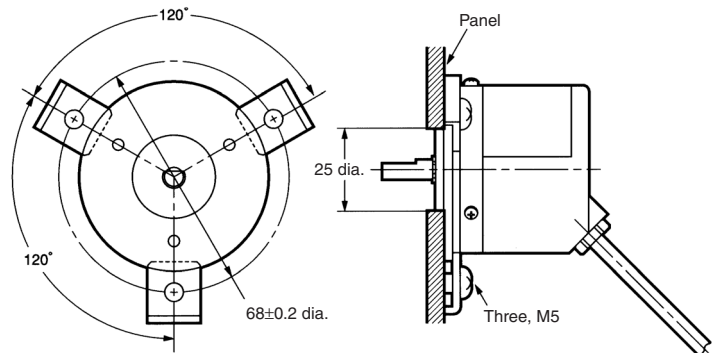

Servo Mounting Bracket

E69-2 (A Set of Three)

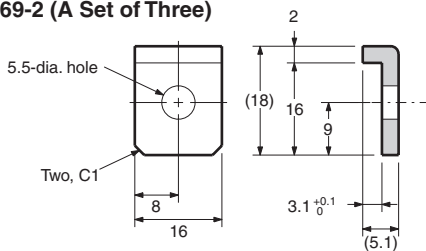

Note: A set of E69-2 Servo Mounting Brackets is provided with the E69-FCA02 Flange.

Installation

■ Connection

E6C2-CWZ6C/-CWZ3E/-CWZ5B

Color	Terminal
Brown	Power supply (+V _{CC})
Black	Output phase A
White	Output phase B
Orange	Output phase Z
Blue	0 V (common)

E6C2-CWZ1X

Color	Terminal
Brown	Power supply (+V _{CC})
Black	Output phase A
White	Output phase B
Orange	Output phase Z
Black/Red stripes	Output phase \bar{A}
White/Red stripes	Output phase \bar{B}
Orange/Red stripes	Output phase \bar{Z}
Blue	0 V (common)

Note: Receiver: AM26LS32 equivalent

■ Connection Examples

H7ER Self-powered Tachometer

Applicable Model: E6C2-CWZ3E (with a resolution of 10 or 60 P/R)

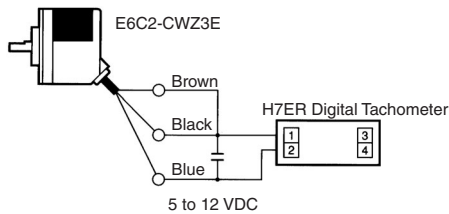

H7BR Digital Counter

Applicable Model: E6C2-CWZ3E

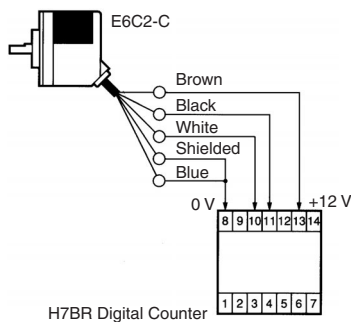

H7CR-CW Digital Counter

Applicable Model: E6C2-CWZ6C

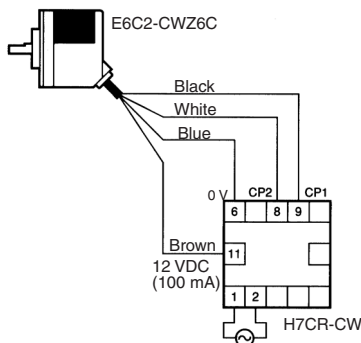

C200H-CT High-speed Counter Unit

Applicable model: E6C2-CWZ6C
Typical model: C200H-CT001-V1

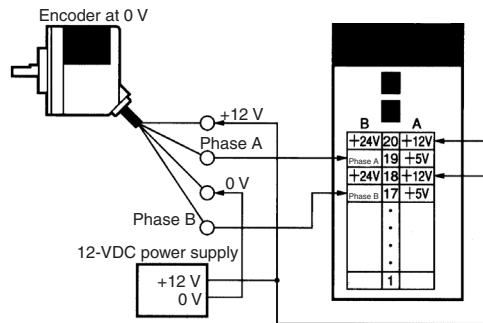

Note: Apply the following connections if the power supply to the E6C2-C is 5 or 24 V.
Phase A and Power Supply: 5 V to A19 and 24 V to B20
Phase B and Power Supply: 5 V to A17 and 24 V to B18

Applicable model: E6C2-CWZ5B
Typical model: C200H-CT021

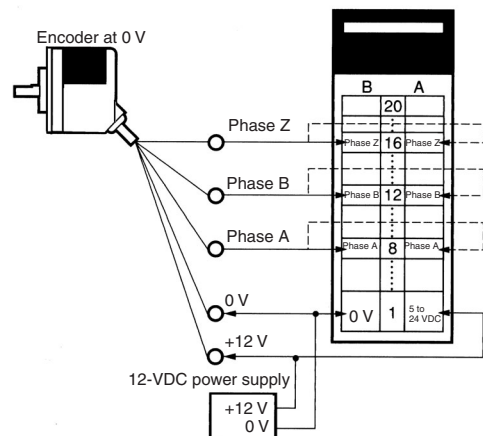

Note: Apply the following connections if the power supply to the E6C2-C is 12 or 24 V.
Phase A and Power Supply: 12 V to A8/B8 and 24 V to A9/B9
Phase B and Power Supply: 12 V to A12/B12 and 24 V to A13/B13
Phase Z and Power Supply: 12 V to A16/B16 and 24 V to A17/B17

CQM1 Programmable Controller

Applicable Model: E6C2-CWZ6C

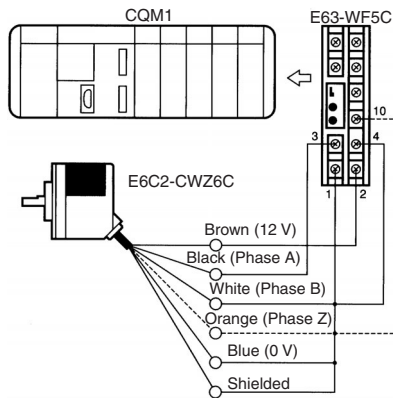

Reset

The present count value can be reset with the soft-reset function or the AND of soft reset and phase Z input.

Output

Target value	When the count value reaches the target value, the specified subroutine is executed. A maximum of 16 target values can be set.
Range comparison	When the count value is within the range, the specified subroutine is executed. A maximum of 8 ranges can be set with upper and lower limits.

C500-CT001/CT012 High-speed Counter Unit

CW and CCW detection (increment/decrement counting)

Applicable Model: E6C2-CWZ6C

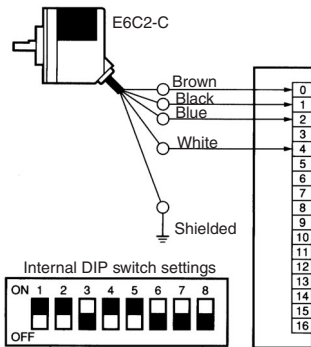

CQM1-CPU43-EV1 (as Built-in High-speed Counter)

The pulse output of the E6C2-C can be directly input into IN04, IN05, and IN06 of the CPU Unit to use these three points as a built-in high-speed counter.

The single-phase response speed is 5 kHz and the two-phase response speed is 2.5 kHz. The count value is within a range between 0 and 65,535 in increment mode and -32,767 and 32,767 in decrement mode.

The operating mode of the high-speed counter is set with the PC Setup in the DM area.

Count Mode

Up/Down mode	Increment/Decrement counter uses phases A and B.
Incrementing mode	Increment counter uses phase A only.
Normal mode	IN04 through IN06 are used for normal input.

Applicable Model: E6C2-CWZ6C

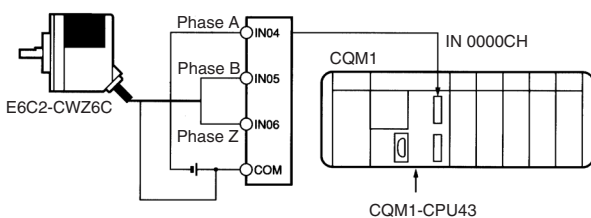

Precautions

⚠ WARNING

This products is not designed or rated for ensuring safety of persons.
Do not use it for such purpose.

1. Do not impose voltage exceeding the rated voltage range on the E6C2-C, otherwise the E6C2-C may be damaged.
2. Be sure that the wiring of power supply to the E6C2-C is correct, otherwise the E6C2-C may be damaged.
3. Turn off the Rotary Encoder when wiring.
4. Do not wire power lines or high-tension lines along with the power supply lines of the E6C2-C Rotary Encoder or the E6C2-C Rotary Encoder may be damaged or malfunction.

■ Precautions for Safe Use

Mounting

Be careful not to spray water or oil onto the E6C2-C Rotary Encoder. The E6C2-C Rotary Encoder consists of high-precision components. Handle with utmost care and do not drop the Rotary Encoder, otherwise malfunctioning may result.

Do not pull the cable of the E6C2-C Rotary Encoder after the E6C2-C Rotary Encoder is mounted to a panel. Do not apply any shock to the hollow shaft or the body.

When the E6C2-C Rotary Encoder is used in reversed operation, pay utmost attention to the mounting direction of the E6C2-C Rotary Encoder and the directions of increment and decrement rotation.

To match phase Z of the E6C2-C Rotary Encoder and the origin of the device to be connected to the E6C2-C Rotary Encoder, conform the phase Z outputs while connecting the device.

Be careful enough not to impose an excessive load on the shaft if the shaft connects to a gear.

If the Rotary Encoder is mounted with screws, the tightening torque must be approximately 0.5 N·m.

If the Rotary Encoder is mounted to a panel, do not pull the cable with more than a force of 30 N.

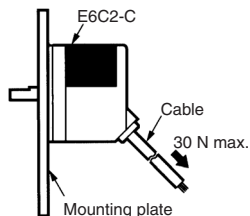

No shock must be given to the shaft or coupling. Therefore, do not hit the shaft or coupling with a hammer when inserting the shaft into the coupling.

Refer to the following illustrations when using a standard coupling.

Decentering tolerance	
Declination tolerance	
Displacement tolerance in the shaft direction	

When connecting or disconnecting the coupling, do not impose an excessive bending, pressing, or pulling force on the E6C2-C. When connecting the shaft of the Rotary Encoder with a chain timing belt or gear, connect the chain timing belt or gear with the shaft via the bearing and coupling as shown in the following illustration.

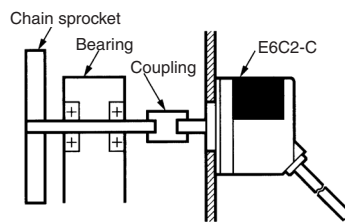

If the decentering or declination value exceeds the tolerance, an excessive load imposed on the shaft may damage the Rotary Encoder or shorten the life of the Rotary Encoder.

Life of Bearing

The following graph shows the life expectancy of the bearing with radial and thrust loads imposed on the bearing. (Theoretical)

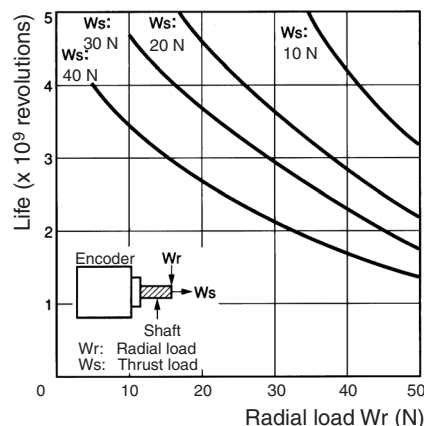

Mounting Procedure

1. Insert the shaft into the coupling.
Do not secure the coupling and shaft with screws at this stage.
2. Secure the Rotary Encoder.
Refer to the following table for the maximum insertion length of the shaft into the coupling.

Model	Maximum insertion length
E69-C06B	5.5 mm
E69-C06M	8.5 mm

3. Secure the coupling.

Model	Tightening torque
E69-C06B	0.25 N·m
E69-C06M	0.7 N·m

4. Connect the power and I/O lines.
Be sure to turn off the Rotary Encoder when connecting the lines.
5. Turn on the Rotary Encoder and check the output.

Connecting

When extending the cord, select the kind of cord with care by taking the response frequency into consideration because the longer the cord is, the more the residual voltage increases due to the resistance of the cord and the capacitance between the wires. As a result, the waveform will be distorted.

We recommend the line driver output type model if the cord needs to be extended.

In order to reduce inductive noise, the cord must be as short as possible, especially when the signal is input to an IC.

Insert a surge absorber between the power supply terminals if there is any surge.

A wrong pulse may be generated when the E6C2-C Rotary Encoder is turned on or off. Do not use the connected device for 0.1 s after the E6C2-C Rotary Encoder is turned on and for 0.1 s before the E6C2-C Rotary Encoder is turned off.

Cord Extension

The rise time of each output waveform will increase when the cord is extended. This affects the phase difference characteristics of phases A and B.

The available length of cord varies with the response frequency and noise. It is safer to limit the length of cord to 10 m maximum. If a longer cord of up to 100 m is required, use line driver output.

Note: Recommended Cord:

- Cross section: 0.2 mm² with spiral shield
- Conductor resistance: 92 Ω/km max. at 20°C
- Insulation resistance: 5 MΩ/km min. at 20°C

The rise time varies with the resistance of the cord and the kind of cord as well as the length of the cord.

The residual output voltage will increase according to the length of the cord.

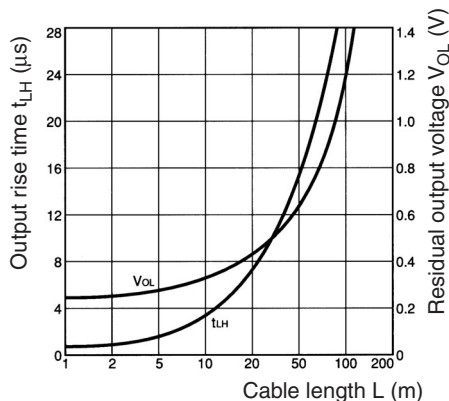

Conditions

- Rotary Encoder: E6C2-CWZ6C
- Load voltage: 5 VDC
- Load resistance: 1 kΩ (The residual output voltages were measured with a load current of 35 mA.)
- Cord: Dedicated cord

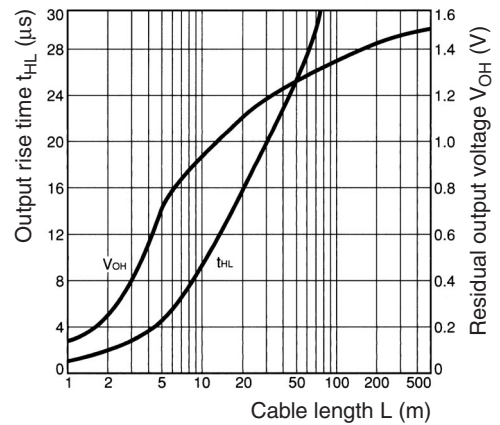

Conditions

- Rotary Encoder: E6C2-CWZ5B
- Load voltage: 12 VDC
- Load current: 5 mA (The residual output voltages were measured with a load current of 35 mA.)
- Cord: Dedicated cord

Preventing Miscounting

If the operation of the E6C2-C Rotary Encoder is stopped near a signal rising or falling edge, a wrong pulse may be generated, in which case the E6C2-C Rotary Encoder will miscount. In such a case, use an increment-decrement counter to prevent miscounting.

Extension of Line Driver Output

Be sure to use a twisted-pair cable to extend a line driver cord. Use an RS-422A Receiver for the receiver side.

The twisted-pair wires as shown in the following illustration are suitable for RS-422A signal transmission. Normal mode noise can be eliminated by twisting the wires because the generated electrical forces on the lines cancel each other.

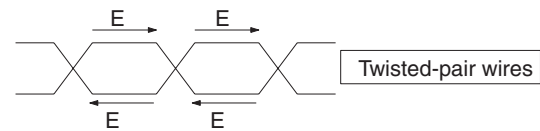

Be sure the E6C2-C Rotary Encoder is supplied with 5 VDC when a line driver output is used. There will be an approximately 1-V voltage drop if the cable length is 100 m.

WARRANTY

OMRON's exclusive warranty is that the products are free from defects in materials and workmanship for a period of one year (or other period if specified) from date of sale by OMRON.

OMRON MAKES NO WARRANTY OR REPRESENTATION, EXPRESS OR IMPLIED, REGARDING NON-INFRINGEMENT, MERCHANTABILITY, OR FITNESS FOR PARTICULAR PURPOSE OF THE PRODUCTS. ANY BUYER OR USER ACKNOWLEDGES THAT THE BUYER OR USER ALONE HAS DETERMINED THAT THE PRODUCTS WILL SUITABLY MEET THE REQUIREMENTS OF THEIR INTENDED USE. OMRON DISCLAIMS ALL OTHER WARRANTIES, EXPRESS OR IMPLIED.

LIMITATIONS OF LIABILITY

OMRON SHALL NOT BE RESPONSIBLE FOR SPECIAL, INDIRECT, OR CONSEQUENTIAL DAMAGES, LOSS OF PROFITS OR COMMERCIAL LOSS IN ANY WAY CONNECTED WITH THE PRODUCTS, WHETHER SUCH CLAIM IS BASED ON CONTRACT, WARRANTY, NEGLIGENCE, OR STRICT LIABILITY.

In no event shall responsibility of OMRON for any act exceed the individual price of the product on which liability is asserted.

IN NO EVENT SHALL OMRON BE RESPONSIBLE FOR WARRANTY, REPAIR, OR OTHER CLAIMS REGARDING THE PRODUCTS UNLESS OMRON'S ANALYSIS CONFIRMS THAT THE PRODUCTS WERE PROPERLY HANDLED, STORED, INSTALLED, AND MAINTAINED AND NOT SUBJECT TO CONTAMINATION, ABUSE, MISUSE, OR INAPPROPRIATE MODIFICATION OR REPAIR.

SUITABILITY FOR USE

THE PRODUCTS CONTAINED IN THIS DOCUMENT ARE NOT SAFETY RATED. THEY ARE NOT DESIGNED OR RATED FOR ENSURING SAFETY OF PERSONS, AND SHOULD NOT BE RELIED UPON AS A SAFETY COMPONENT OR PROTECTIVE DEVICE FOR SUCH PURPOSES. Please refer to separate catalogs for OMRON's safety rated products.

OMRON shall not be responsible for conformity with any standards, codes, or regulations that apply to the combination of products in the customer's application or use of the product.

At the customer's request, OMRON will provide applicable third party certification documents identifying ratings and limitations of use that apply to the products. This information by itself is not sufficient for a complete determination of the suitability of the products in combination with the end product, machine, system, or other application or use.

The following are some examples of applications for which particular attention must be given. This is not intended to be an exhaustive list of all possible uses of the products, nor is it intended to imply that the uses listed may be suitable for the products:

- Outdoor use, uses involving potential chemical contamination or electrical interference, or conditions or uses not described in this document.
- Nuclear energy control systems, combustion systems, railroad systems, aviation systems, medical equipment, amusement machines, vehicles, safety equipment, and installations subject to separate industry or government regulations.
- Systems, machines, and equipment that could present a risk to life or property.

Please know and observe all prohibitions of use applicable to the products.

NEVER USE THE PRODUCTS FOR AN APPLICATION INVOLVING SERIOUS RISK TO LIFE OR PROPERTY WITHOUT ENSURING THAT THE SYSTEM AS A WHOLE HAS BEEN DESIGNED TO ADDRESS THE RISKS, AND THAT THE OMRON PRODUCT IS PROPERLY RATED AND INSTALLED FOR THE INTENDED USE WITHIN THE OVERALL EQUIPMENT OR SYSTEM.

PERFORMANCE DATA

Performance data given in this document is provided as a guide for the user in determining suitability and does not constitute a warranty. It may represent the result of OMRON's test conditions, and the users must correlate it to actual application requirements. Actual performance is subject to the OMRON Warranty and Limitations of Liability.

CHANGE IN SPECIFICATIONS

Product specifications and accessories may be changed at any time based on improvements and other reasons.

It is our practice to change model numbers when published ratings or features are changed, or when significant construction changes are made. However, some specifications of the product may be changed without any notice. When in doubt, special model numbers may be assigned to fix or establish key specifications for your application on your request. Please consult with your OMRON representative at any time to confirm actual specifications of purchased products.

DIMENSIONS AND WEIGHTS

Dimensions and weights are nominal and are not to be used for manufacturing purposes, even when tolerances are shown.

ERRORS AND OMISSIONS

The information in this document has been carefully checked and is believed to be accurate; however, no responsibility is assumed for clerical, typographical, or proofreading errors, or omissions.

PROGRAMMABLE PRODUCTS

OMRON shall not be responsible for the user's programming of a programmable product, or any consequence thereof.

ALL DIMENSIONS SHOWN ARE IN MILLIMETERS.

To convert millimeters into inches, multiply by 0.03937. To convert grams into ounces, multiply by 0.03527.

Cat. No. Q109-E1-05

In the interest of product improvement, specifications are subject to change without notice.

OMRON Corporation

Industrial Automation Company

Sensing Devices Division H.Q.

Industrial Sensors Division

Shiokoji Horikawa, Shimogyo-ku,

Kyoto, 600-8530 Japan

Tel: (81)75-344-7022/Fax: (81)75-344-7107

Printed in Japan

0805-0.5C (0997) (M)