

ACCU ELECTRIC MOTORS INC

USA: (888) 932-9183

CANADA: (905) 829-2505

- ✓ Over 100 years cumulative experience
- ✓ 24 hour rush turnaround / technical support service
- ✓ Established in 1993



The leading independent repairer of servo motors and drives in North America.

Visit us on the web:

www.servo-repair.com

www.servorepair.ca

www.ferrocontrol.com

www.sandvikrepair.com

www.accuelectric.com

Scroll down to view your document!

For 24/7 repair services :

USA: 1 (888) 932 - 9183

Canada: 1 (905) 829 -2505

Emergency After hours: 1 (416) 624 0386

Servicing USA and Canada



Four-Axis DC Servo Controller With Built-In Power Amplifiers

LS-421

Technical Reference

The information in this data book has been carefully checked and is believed to be reliable, however, no responsibility can be assumed for inaccuracies. All information in this manual is subject to change without notice and does not represent a commitment on the part of the vendor.

FlexWare™ is trademark of Logosol, Inc.

Trademarks are used throughout the manual only as reference to existing common products. If a registered trademark is used without being indicated as such, this does not imply that the name is free.

© Copyright Logosol, Inc. 1991 - 1999.

All rights reserved. No part of this publication may be reproduced, photocopied, stored on retrieval system, or transmitted without the express written consent of the publisher.

LS-421 Technical Reference
Document No 710420103 / Rev. 1.2 - April, 1999

Logosol, Inc.
1155 Tasman Drive, Sunnyvale, CA 94089
Tel: (408) 744-0974
Fax: (408) 744-0977
[Http://www.logosolinc.com](http://www.logosolinc.com)

Preface

Thank you for choosing Logosol Motion Controller for addressing your automation needs. Logosol is committed to providing products with exceptional value and functionality.

LS-421 Motion Control Board is an integrated product, which combines three major functions in one board: *Motion Control, I/O Control and Power Amplification*. This innovative approach significantly reduces the overall dimensions of the controller, eliminates a large number of redundant components and offers a variety of custom options.

We sincerely hope this manual will help you quickly and efficiently integrate the board into your system.

Table of Contents

I. HOW TO USE THIS MANUAL.....	5
II. INSTALLATION.....	6
❑ Requirements.....	6
❑ Preparing the Board.....	7
Inspection	7
Jumper Settings	7
Interface Connectors	10
LED Indicators	11
❑ Installation Procedure	11
III. HARDWARE REFERENCE.....	13
❑ Architecture Overview	13
Controller Architecture	14
Memory Map	17
❑ Base Module.....	18
Board Layout.....	18
Motion Processor	19
Built-in Power Amplifiers.....	22
Digital Outputs and Outbound Power	24
Servo Control and Diagnostics Circuit.....	26
Interrupt Request Lines	32
Board Identifier.....	32
Interface Connectors	34
❑ Input Board	37
Digital Optoisolated Inputs	39
Incremental Encoder Interface	43
Multi-turn Absolute Encoder Receiver	45
❑ Interface Wiring.....	48
❑ External Power Supply	49
IV. BASIC CONTROL PROCEDURES	50
Board Identification	51
Board Initialization and Power On	52
Enable Amplifiers	53
Disable Amplifiers	54
Diagnostics	55
V. APPENDIX A.....	56

- **Technical Specification 56**
 - Basic Features 56
 - Motion Control..... 57
 - Digital I/O lines..... 57
 - Power Requirements..... 57

- VI. APPENDIX B: MEMORY MAP 58**

I. How To Use This Manual

This manual describes LS-421 motion control board. It is intended to serve as a hardware reference for system integrators. This publication includes information about the following topics:

- *Installation.* This chapter presents the requirements to the host system and a step by step procedure how to install the board into your system. Board setup issues, including jumper specification and external power connector pinout are covered.
- *Hardware Reference.* It describes the controller architecture and hardware features, including servo channels, power amplifiers, digital inputs and outputs, encoder interface, etc. The functioning of hardware protection and diagnostics circuits is discussed in detail. This chapter includes also interface connector specification and power requirements for external power sources.
- *Basic Control Procedures.* This part presents typical procedures for initialization, diagnostics and control as flowcharts.
- *Appendixes* provide additional reference information. The technical specification of the controller is given in Appendix A. The memory map is given in Appendix B.

II. INSTALLATION

Logosol Motion Control Board LS-421 is a flexible automation device suitable for many different types of applications. For a specific application the board must be configured using particular jumper and interface connector options. In addition to the hardware settings, some of the features of the board are software configurable (e.g. motor current limits). This chapter explains the configuration process and states the requirements to the host system, where the product will be installed.

Disclaimer

Logosol assumes no responsibility for damages or injuries incurred to your system or to the operating personnel, due to improper installation. As with any product designed for industrial applications, a professional in Electronics Engineering should install the board.

The hardware installation may require a certain level of knowledge on the service and maintenance procedures for the computer system where the board will be installed, which will be further referred to as *the host system*. Consult the service documentation of your host before beginning to install the board.

If you are not familiar with installation of electronic components seek help from a computer service engineer or contact Logosol for installation support.

□ REQUIREMENTS

Logosol LS-421 is a plug-in board for a standard ISA bus system. To operate LS-421, the host system must meet the following requirements:

- ISA bus system

- One vacant 8-bit or 16-bit bus slot. LS-421 itself occupies space for two single-size PC-boards. Only one bus slot connector is used.
- A minimum of 512 Kbytes conventional RAM installed
- A free I/O address range $x280h \rightarrow x28Fh$ or $x2A0h \rightarrow x2AFh$, where x may be 0, 1, 2 or 3
- Computer power (from the ISA bus): $+5V \pm 5\%$ / 1A, $+12V \pm 5\%$ /1A
- External operating power: 24V DC $\pm 20\%$
- External motor power in the range: 24-80V DC
- A cooling fan when driving high power motors (having consumption greater than 3A @ 48V)

Caution

Motor power supply must be electrically isolated from computer ground and from operating power supply (floating power supply).

□ PREPARING THE BOARD

Inspection

Inspect the board for any signs of damage. LS-421 was thoroughly tested and burned-in, including tests on real motors and carefully packed before shipment. Yet, there always exists a slight possibility of shipping damage. In case there is any noticeable imperfection, please report this to Logosol immediately.

Jumper Settings

There are four jumper blocks on the board (J1 – J4) for the configuration of the following hardware features:

- Base I/O Address (J1)
- Interrupt Request Line (J2)

- Current Limit Mode (J3)
- Servo Off Mode (J4)

Take a moment to locate the jumpers on the board and get familiar with their setting, described under the following topics.

■ BASE I/O ADDRESS

Eight base addresses are available, depending on J1 setting – 0x0280, 0x1280, 0x2280, 0x3280, 0x02A0, 0x12A0, 0x22A0, 0x32A0. Thus, up to 8 boards may be installed in one host computer (not more than 4 if IRQ lines is used).

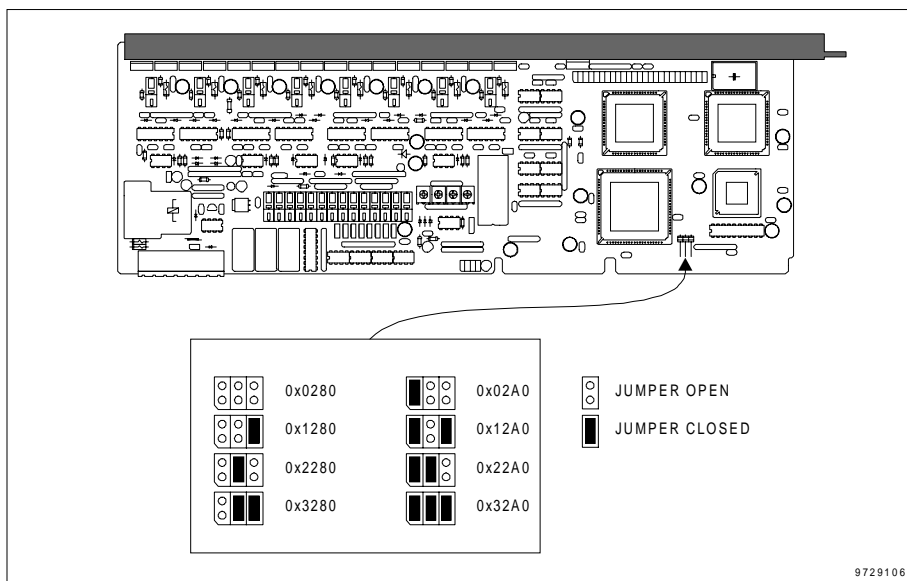

Figure 1: Base I/O Address (J1 jumper block)

■ INTERRUPT REQUEST LINE

The use of a hardware interrupt is optional for the functioning of the LS-421 motion controller. Consult your software documentation to find out if your host software requires interrupt support.

There are four hardware interrupt lines to choose from: 7, 10, 12 and 15. Each LS-421 board should have a unique IRQ line. This interrupt should not be shared with other device hosted in your system.

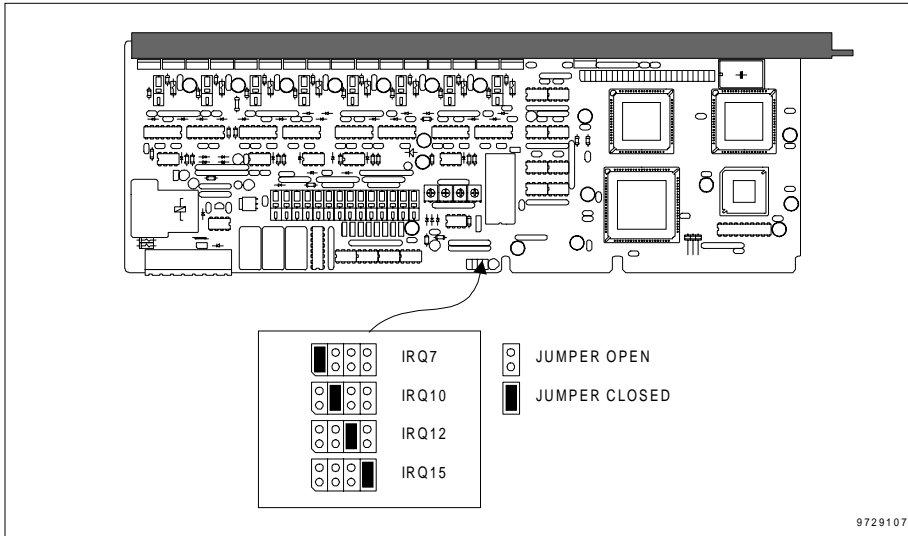

Figure 2: Interrupt line (J2 jumper block)

■ CURRENT LIMIT MODE

Motor current overload protection has two modes of operation depending on J3 jumper settings: *shutdown* or *current limitation*. With J3 jumper installed, the power amplifiers will be automatically shut down. If J3 is left open, the amplifiers will remain enabled, regardless of the overload, with the output motor current limited to the specified value (current limitation mode). See also “Built-In Power Amplifiers” on page 22.

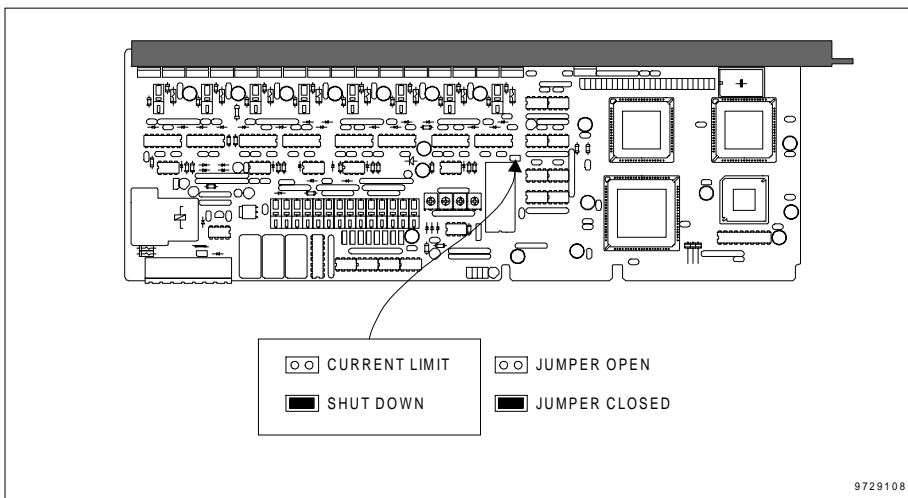

Figure 3: Current Limit Mode (J3 jumper)

■ SERVO OFF MODE

Depending on J4 jumper setting, the motors windings are shorten (J4 closed), or left open (J4 open), when amplifiers are disabled due to a hardware exception. A short circuit on the motor windings provides faster stopping compared to open windings but stopping with open windings is smoother. See also “Built-In Power Amplifiers” on page 22.

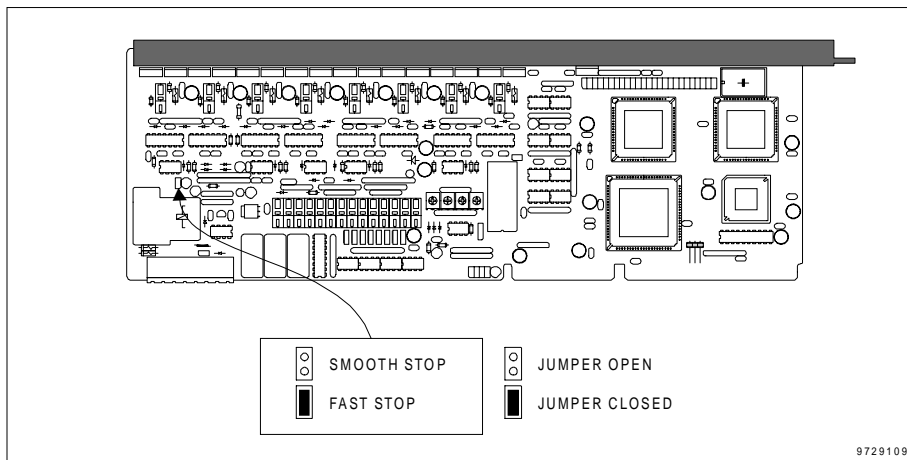

Figure 4: Servo Off Mode (J4 jumper)

Interface Connectors

■ CN3 CONNECTOR (EXTERNAL POWER)

The CN3 connector located on the bottom side of the board (in-line with the ISA bus connector) is the entry point for the external motor and operating power supplies. The terminals of the emergency stop input are also located there. A schematic drawing of the location and pinout of the CN3 connector is shown in Figure 12 on page 35.

■ FRONT PANEL CONNECTOR

The front panel connector provides the interface to the controlled equipment. The standard front-panel connector for LS-421 motion controller is a 56-pin ELCO connector, shown in Figure 23 on page 48. Customized versions of LS-421 may be equipped with a different front-panel interface connector. Check the documentation that comes with your system to verify the type of connector that is installed with your system.

LED Indicators

The LS-421 board is equipped with two LED indicators (L1 and L2) for a fast and easy visual check of the controller status. In order to close the servo loop and enable the power amplifiers both LEDs must be ON. The location of L1 and L2 is shown in Figure 7 on page 19.

The L1 indicator is ON if the all of the following conditions are met:

- Computer power is present
- The controller is initialized
- Motor power supply is present
- There is not a short circuit between a motor terminal and the computer ground or between a motor terminal and the ground of the operating power.

The L2 indicator is ON if all of the following conditions are met:

- Operating power is present
- None of the digital outputs is overloaded.

❑ INSTALLATION PROCEDURE

- *Power Off.* Disconnect the power to the host system. Never touch electronic circuits or wiring while power is on. This protects you and your hardware.
- *Static Electricity Precautions.* Use a properly grounded and static electricity safe workbench when performing the installation. Touch electrical ground to eventually discharge all static electricity accumulated in your body.
- *Board Setup.* Select the I/O address with J1 jumper block. Optionally select IRQ line with J2 jumper block. Setup the Servo off Mode (J4) and Current Limit Mode (J3). See jumper layouts in section “Jumper Settings ” on page 7, earlier in this chapter.
- *External Power.* Plug in the main power connector CN3. Check power supply – motor power (24→80V) and operating power (24V). Make sure the emergency stop contact between pins 7 & 8 of CN3 connector is closed.
- *Insert in Slot.* Plug in LS-421 into a free ISA-bus slot. Any slot may be used.

- *Screw the Board.* Fix LS-421 with a screw to the chassis. Never switch on the power before LS-421 is fixed to the chassis. The board might have tilted within the slot and short-circuited the bus with unpredictable results.
- *Test the installation.* Switch on your system and check whether or not the board interferes with the normal computer operation. Switch on the LS-421 external power supply. Run the application software.

III. Hardware Reference

This chapter explains in detail the hardware features available in LS-421 motion controller. The subjects in it are organized to reflect the overall structure of the controller, which is an assembly of three modules (Base Module, Input Board and Interface Wiring):

- *Architecture Overview* is a brief description of the controller structure and features.
- *Base Module* describes the hardware components and features supported by the Base Module, among which are the Motion Processor, the Digital Outputs and the Servo Control and Diagnostics circuit.
- *Input Board* explains Digital Inputs, Incremental Encoder Interface and Absolute Encoder Interface, located on that module
- *Interface Wiring* gives the schematics of the wiring, which connects the Base Module, the Input Board and the front-panel interface connector.
- *External Power Supply* states the requirements to the external power sources and offers an example scheme for a typical external power supply

□ ARCHITECTURE OVERVIEW

LS-421 is a 4-axis multipurpose servo controller with built-in power amplifiers for DC motors with quadrature incremental encoders. It is designed to meet the requirements for high precision and high reliability essential to industrial applications. The board is designed as a plug-in board for PC/AT compatible computers with ISA bus. The unique *FlexWare™* design allows flexible wiring and pin assignment to meet specific requirements and to achieve compatibility with the existing hardware. To attain higher reliability of operation in industrial environments, all inputs and outputs are optoisolated from the computer ground.

To deliver ultimate performance and adaptability to different applications LS-421 is designed using the latest achievements in IC technology. The onboard 25MHz PMD MC1401A DSP processor guarantees precise and smooth motion control, and uses sparingly the host computer resources. In this manual, the MC1401A chipset is referred to as the Motion Processor (MP).

All input, output and control signals are processed by an In-System Programmable (ISP) chipset to allow fast and easy user-defined customizations. This approach allows easy factory customizations of the controller input and output assignments.

LS-421 controller is equipped with the following hardware safety features:

- Emergency stop input
- Output overload protection
- Amplifier overcurrent protection
- Motor power undervoltage and short circuit protection
- Operating power undervoltage protection
- A dedicated diagnostics circuit for identification of the causes for hardware exceptions and activation of protection circuits (e.g. disabling the amplifiers).

Controller Architecture

LS-421 is a three-piece assembly, which consists of the following components:

- A mother-board referred to as Base Module (BM)
- A plug-in board that supports all input circuits, referred to as Input Board (IB)
- An Interface Wiring (IW) to connect BM and IB to the LS-421 front panel connector

BM can be combined with various types of IBs to create the optimal solution in each motion control application. The standard IB available from Logosol and compatible with the LS-421 BM is LS-421-2112.

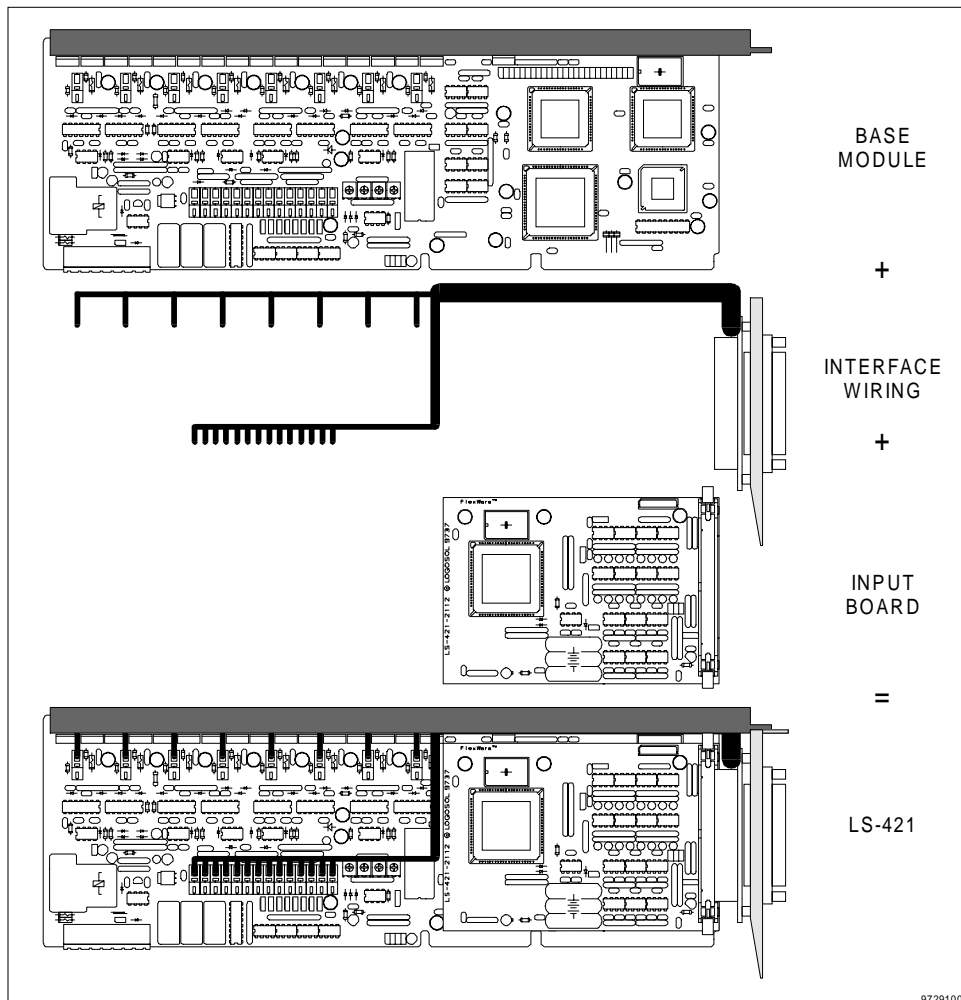

Figure 5: LS-421 main components

With respect to function, LS-421 provides the following modules:

- *Motion Processor*, implemented as a DSP motion control chipset (MC1401A)
- *Power Amplifiers* with PWM output
- *Incremental Encoder Receiver*
- *Absolute Position Encoder Receiver*
- *Digital Inputs*
- *Digital Outputs*

- *Servo Control and Diagnostics Circuit*, which controls motor amplifiers, digital outputs, outbound power sources and the IRQ line to the host, based on host commands or on signals coming from on-board protection circuits.
- *Power Supply*, which controls three outbound power lines.

The interconnections between the above functional modules are presented in the following figure:

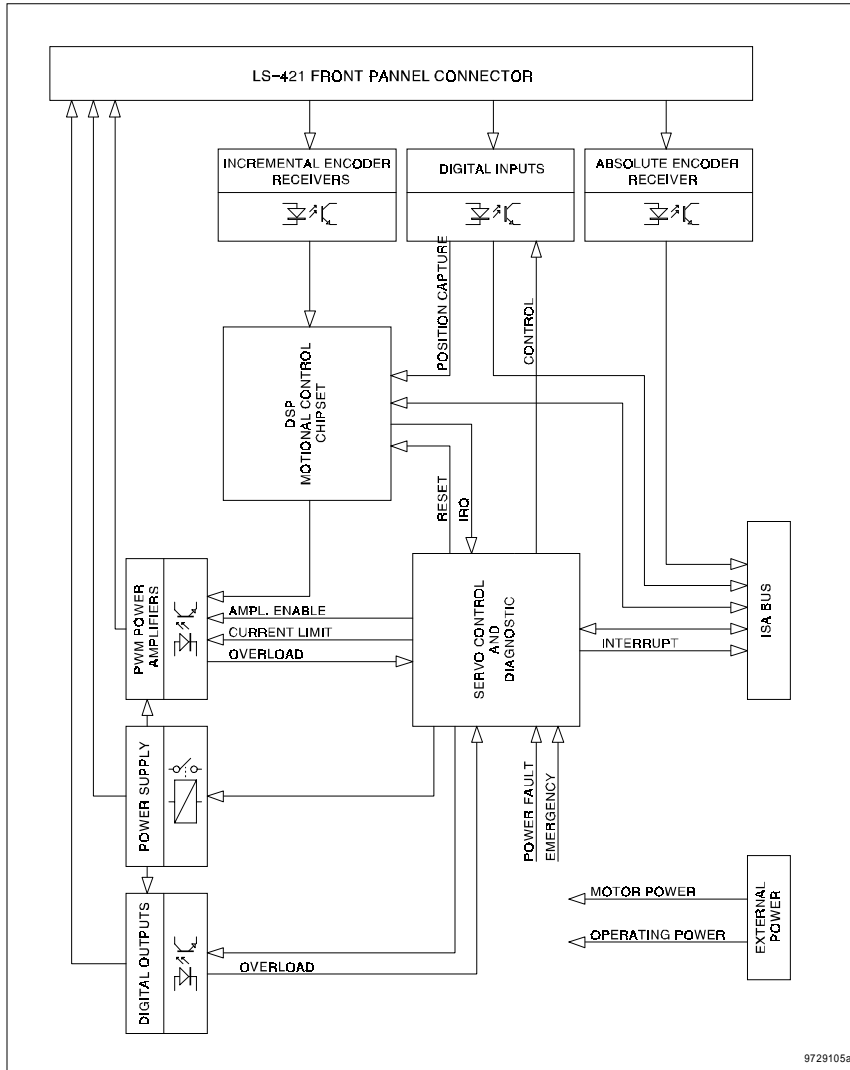

Figure 6: LS-421 block diagram

Memory Map

LS-421 is designed as a standard ISA bus peripheral device. The host system communicates with the LS-421 motion controller using designated port addresses.

To save I/O space, LS-421 uses only 16 bytes from the lowest 1024 I/O addresses range. The rest of LS-421 registers occupy the space located at offset 0x400, 0x800 and 0xC00. For instance, if LS-421 base address is set to 0x280, the following I/O address are in use – 0x280÷0x28F, 0x680÷0x68F, 0xA80÷0xA8F, 0xE80÷0xE8F. Eight base addresses are available, depending on J1 setting – 0x280, 0x1280, 0x2280, 0x3280, 0x2A0, 0x12A0, 0x22A0, 0x32A0. See “Jumper Settings: Base I/O Address” on page 8.

In this manual and in other reference sources, registers are named consistently with three to six-letter abbreviations, which correspond to their function. The table below shows LS-421 register locations relative to controller base address. The offsets are in hexadecimal notation.

READ								WRITE									
D7	D6	D5	D4	D3	D2	D1	D0	D7	D6	D5	D4	D3	D2	D1	D0		
MC1401A DATA REGISTER								MC1401A COMMAND REGISTER									
0	READY							0									
1								1									
2								2									
3								3									
4								4									
5								5									
6								6									
7								7									
8	IN7	IN6	IN5	IN4	IN3	IN2	IN1	IN0	8								
9	IN15	IN14	IN13	IN12	IN11	IN10	IN9	IN8	9								
A	AE	RST	OPT	SPS	CL3	CL2	CL1	CL0	A	AE	RST	OPT	SPS				
B	EMG	STP	MPF	OPF	EMGL	STPL	MPFL	OPFL	B								
C	ADI							MPI		C	ENADI						
D	OUT7	OUT6	OUT5	OUT4	OUT3	OUT2	OUT1	OUT0	D	OUT7	OUT6	OUT5	OUT4	OUT3	OUT2	OUT1	OUT0
E								E	PCS3	PCS2	PCS1	PCS0	APERES				
F								F									
400								400									
401								401									
402								402									
403								403									
404	APE D7	APE D6	APE D5	APE D4	APE D3	APE D2	APE D1	APE D0	404	REQ APE#0							
405	APE D15	APE D14	APE D13	APE D12	APE D11	APE D10	APE D9	APE D8	405	REQ APE#1							
406	APE D23	APE D22	APE D21	APE D20	APE D19	APE D18	APE D17	APE D16	406	REQ APE#2							
407	APE RDY	BE		OF	OS	BA	PS	CE	407	REQ APE#3							
408								408	CURRENT LIMIT #0 (0x0 - 0xF)								
409								409	CURRENT LIMIT #1 (0x0 - 0xF)								
40A								40A	CURRENT LIMIT #2 (0x0 - 0xF)								
40B								40B	CURRENT LIMIT #3 (0x0 - 0xF)								
40C								40C									
40D								40D									
40E								40E									
40F								40F									
807				ID3 = 0	ID2 = 0	ID1 = 0	ID0 = 1	807									
C07				ID7 = 1	ID6 = 0	ID5 = 1	ID4 = 1	C07									

Table 1: LS-421 Memory Map

□ BASE MODULE

This section explains the main parts and controls contained in the Base Module (BM) of the LS-421 Motion Control Board. The Base Module is the main part of LS-421 servo controller and it plays the role of a motherboard for the Input Board (IB) module.

The Base Module supports the following functional modules:

- Motion control processor
- Pulse width modulation (PWM) motor power amplifiers
- Optoisolated digital outputs,
- Servo Control and Diagnostics (SCD) logic circuit.

Board Layout

The board layout with call-outs to those parts, which can be monitored, manipulated or adjusted in order to setup or service the board, is presented in Figure 7. Some of the designated components are not user-serviceable.

The BM board is equipped with two LED indicators, denoted as L1 and L2, for fast and easy visual check of the controller status. In order to close the servo loop and enable the power amplifiers both LED must be ON.

The L1 indicator is ON if the all of the following conditions are met:

- Computer power is present
- The controller is initialized
- Motor power supply is present
- There is not a short circuit between a motor terminal and the computer ground or between a motor terminal and the ground of the operating power.

The L2 indicator is ON if all of the following conditions are met:

- Operating power is present
- None of the digital outputs is overloaded.

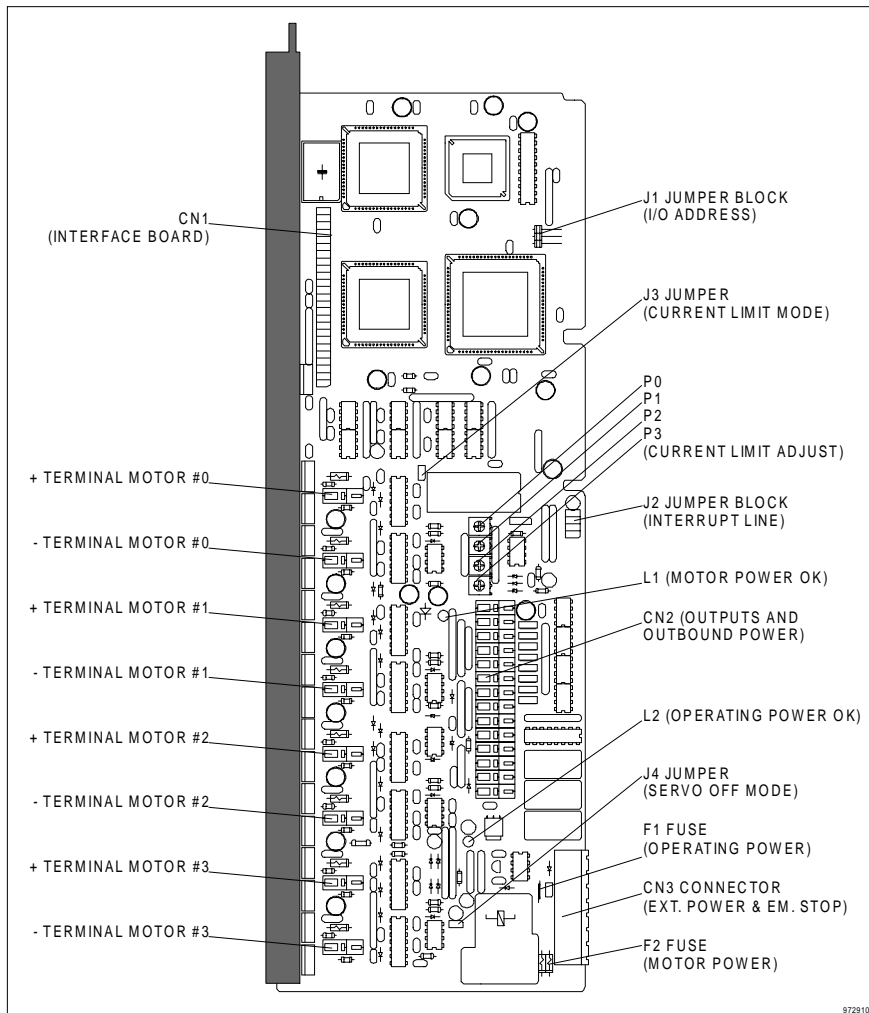

Figure 7: Base Module Board Layout

Motion Processor

LS-421 implements the latest Digital Signal Processing (DSP) technology for maximum performance and precision. The controller is based on MC1401A motion control chipset from Precision Motion Devices, Inc (PMD).

The MC 1401A consists of two 68-pin PLCC chips:

- Peripheral input/output IC (I/O chip)

- Command Processor IC (CP chip)

The CP and I/O chips function together as one integrated motion processor (MP). Interconnection between the two chips consists of a data bus and various control and synchronization signals, which are implemented in the hardware of the BM.

The MP employs three interfaces to the LS-421 board:

- Encoder interface
- Amplifier interface
- Host interface

Within the LS-421 board architecture, the amplifier interface is connected to the Base Module, the encoder interface is connected to the Input Board and MP *Host Processor Interface* is represented in the MP-CMD and MP-DAT registers (see next sections).

MP performs the following functions:

- Reads quadrature encoder signals and accumulates current encoder position.
- Generates PWM motor output signals, which are fed to the motor power amplifiers
- Closes the servo loop, based on Proportional-Integral-Derivative (PID) + Velocity Feed Forward (Vff) + DC bias digital servo filtering. Open-loop motor control is also feasible.
- Performs high-speed position capture (latching), triggered by external signals
- Generates the trajectory profile. The following types are supported: S-curve, trapezoidal, velocity contouring, electronic gearing
- Checks motor torque limits
- Detects and recovers from excessive motion error, when motion is stopped abruptly by a protection circuit.
- Interprets host commands sent to MP
- Sets MP host interrupts
- Maintains MP status information

The following features of the MP1401 chipset are not supported in the LS-421 motion controller:

- The control lines for travel limit switches are not connected. Thus MP axis status will never report travel limit exceeded.

- *Index* and *Home* high-speed position capture lines of the MP are connected together. Thus, position-latching signals from LS-421 (index pulses or inputs designated for position capture) will activate both *Index* and *Home* lines. The host software may choose which of one of them to use for position capturing.

■ **ENCODER INTERFACE.**

Quadrature encoder signals are fed from the LS-421 IB to the I/O chip. See “Input Board: Incremental Encoder Interface” on page 43.

■ **AMPLIFIER INTERFACE**

The motor output signals are connected to the PWM control chip on BM. See “Build-In Power Amplifiers on page 22.

■ **HOST INTERFACE**

LS-421 provides the necessary environment for the MP chipset. Within the LS-421 architecture MP is interfaced via an 8-bit bi-directional bus (MP bus) and various control signals.

To the host system, LS-421 provides a simplified and transparent communication interface to MP through two 8-bit registers, which are accessible by the host system at specific addresses:

- Motion Processor Command Register (MP-CMD)
- Motion Processor Data Register (MP-DAT)

Commands and data are transferred from the MP-CMD and MP-DAT registers to the MP bus. LS-421 is responsible for setting the correct levels for the MP control lines, based on the current host operation (read or write to the respective register), thus simplifying host to MP communication and synchronization. The host is synchronized with MP by poling the READY bit before writing to the MP-CMD or MP-DAT registers.

	R/W access	D7	D6	D5	D4	D3	D2	D1	D0
Base Addr + 0	R/W	MP-DAT							
Base Addr + 1	Write	MP-CMD							
Base Addr + 1	Read	READY							

Table 2: MC1401A register location

MP command set is made of single-byte commands. Data is organized in 16-bit words. All data is encoded “high to low”, i.e. each 16-bit word is encoded high byte first, low byte second, and two word data values are encoded high word first, low word second. Commands could be of one of the following three types:

- Dataless command

- Write command
- Read command

All commands associated with data (read or write) have either 1 or 2 words of data.

The host system must comply with the following requirements when sending a command and reading or writing data to the MP:

- To send a command, the host must write the command code to the MP-CMD register first, then write or read the words of data to the MP-DAT register, if any.
- Each write operation to the MP-CMD register must be preceded by poling (reading repeatedly) the READY register to confirm that MP is available to receive the command.
- Each writing / reading of the high byte of each word to / from the MP-DAT register must be preceded by poling the READY register to confirm that MP is available to receive data or that the data contained in MP-DAT is valid for reading. This poling is not necessary between the bytes of each word (before reading / writing the second byte).

Additional information about the MP chipset may be found in the MC1401A Reference Manual available from Performance Motion Devices, Inc.

Built-in Power Amplifiers

Each LS-421 servo channel is equipped with a built-in power amplifier, capable of delivering up to 10A. The amplifiers are designed as H-bridges with FET transistors (IRF9540 and IRC530). To achieve high noise immunity and reliability, the power circuits are optoisolated from the computer ground.

A special circuit adjusts PWM signals, generated by the Motion Processor, to meet the power bridges requirements.

■ ENABLING AND DISABLING THE POWER AMPLIFIERS

Servo Control and Diagnostics (SCD) logical circuit controls the amplifier enable (AE) signal. The amplifiers are immediately shut down in the following cases:

- Power failure
- Excess motor current
- Digital output overload
- Emergency stop circuit is activated.

The code of the event, which has disabled the amplifiers is latched in a special register and is available to the host for diagnostics. The functioning of SCD is explained in detail in “Servo Control and Diagnostics Circuit” on page 26.

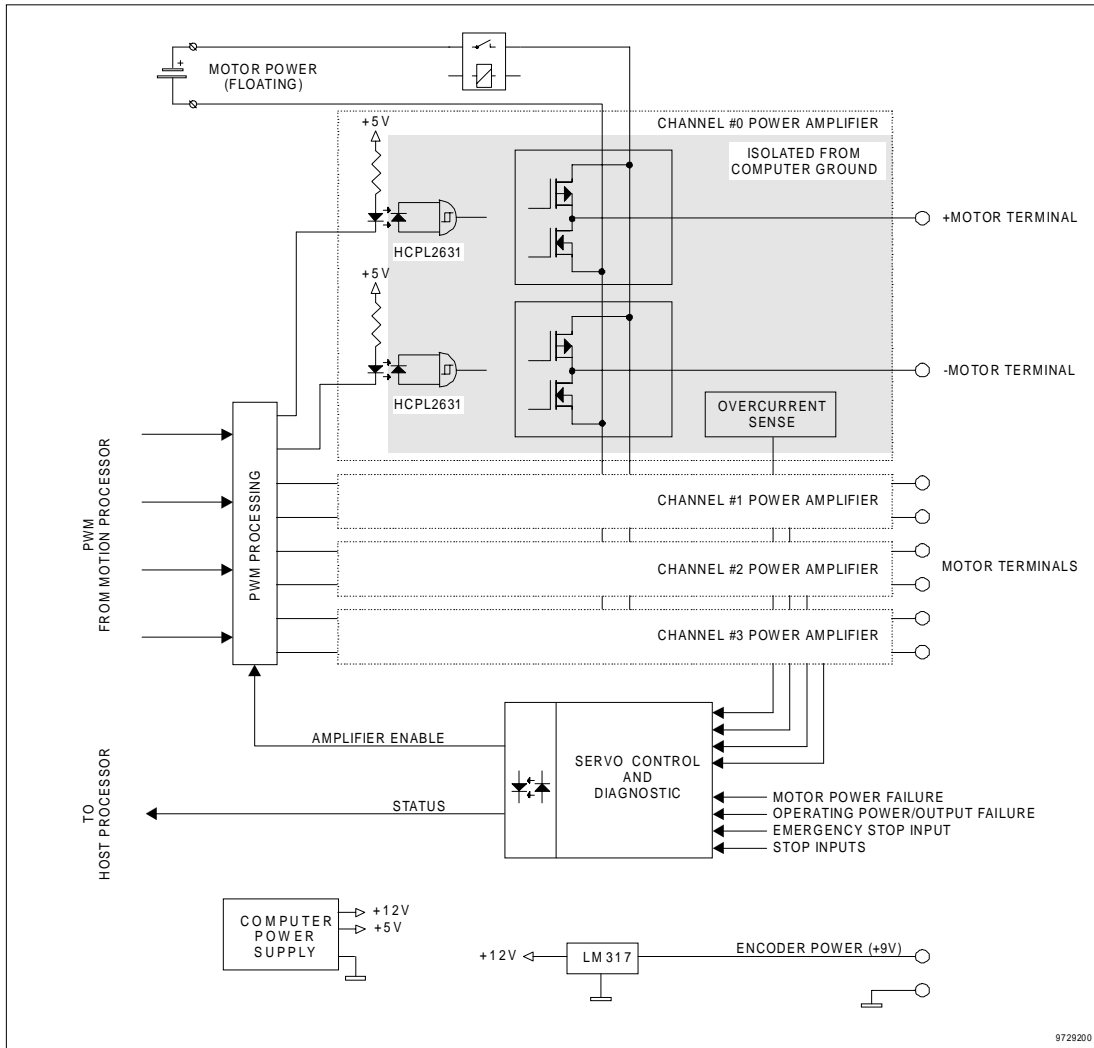

Figure 8: Build-in Power Amplifiers

■ SERVO-OFF MODE

If the amplifiers are disabled while the motors are moving, they can stop in one of two ways depending on J4 jumper setting. When J4 is installed, the motors windings are shorted, while if J4 is left open, the motors have their windings open. A short circuit on the motor windings provides faster stopping compared to open windings and may help prevent eventual collapsing of mechanical parts under their own weight. On the other hand stopping with open windings is

smoother. For the location of the J4 jumper on the LS-421 board, see “Jumper Settings” on page 9.

■ MOTOR BRAKES

If the controlled motors or the actuated mechanisms are equipped with brakes, they can be automatically activated when the amplifiers are disabled. To obtain this functionality, the brakes should be powered by OPS outbound power source and be normally closed (the axis is stopped when the brake is not activated). This happens, because OPS is controlled by the AE signal. See “Digital Outputs and Outbound Power” on page 24.

■ CURRENT LIMITS

The output current from each H-bridge is continuously monitored by a protection circuitry and is limited to a value adjustable in the range of 2÷10A. The limit for each axis can be programmed individually using a special register. The range 2÷10A is divided into 16 steps. A trimmer-pot (P0, P1, P2, P3) may be used for precise adjustment of the selected limit. If an amplifier output is overloaded or shortened, the H-bridge output current protection is activated. The protection has two modes of operation depending on J3 jumper setting. With J3 jumper installed the servo loop will be shut down automatically and the PWM power amplifiers will be disabled. If J3 is left open, the amplifiers will remain enabled regardless of the overload duration. The output current is limited to the specified value. For the location of the J3 jumper on the LS-421 board, see “Jumper Settings” on page 9.

Digital Outputs and Outbound Power

Being a fully integrated servo controller, LS-421 offers, in addition to the servo channels, 8 general-purpose digital outputs equipped with high voltage, high current FET transistors. It also features three relay controlled power sources. The relays and the respective power sources are named based on their typical usage.

- *System Power Supply (SPS)*. The SPS relay is used as main system power switch. It connects (disconnects) the operating power (24V) from a number of circuits on the BM. The output from the SPS relay is fed to the OPT and OPS outbound power circuits. It also controls the normally open motor power relay. Thus, turning SPS off will disable the power amplifiers, as well as OPS and OPT. The circuit controlling the digital outputs is also powered by SPS and turning SPS off will switch off the digital outputs. The output from the SPS relay is available as an outbound power source (24V), immediately following controller initialization. SPS outbound power is normally used to power sensors in the controlled equipment. This guarantees that the user sensors will remain powered all the time except when the emergency input is activated.
- *OPTIONal Power Supply (OPT)* is a general-purpose power source and may be controlled individually. SPS must be ON to enable OPT.

- *Output Power Supply (OPS)* is used basically to power motor breaks and various user valves and switches. OPS can not be controlled separately. Its state depends on amplifier enable status and SPS status. If the power amplifiers are disabled or the SPS is off, OPS is off. This is useful for devices that should be shut off automatically when the amplifiers are disabled, for instance motor breaks or other emergency circuits.

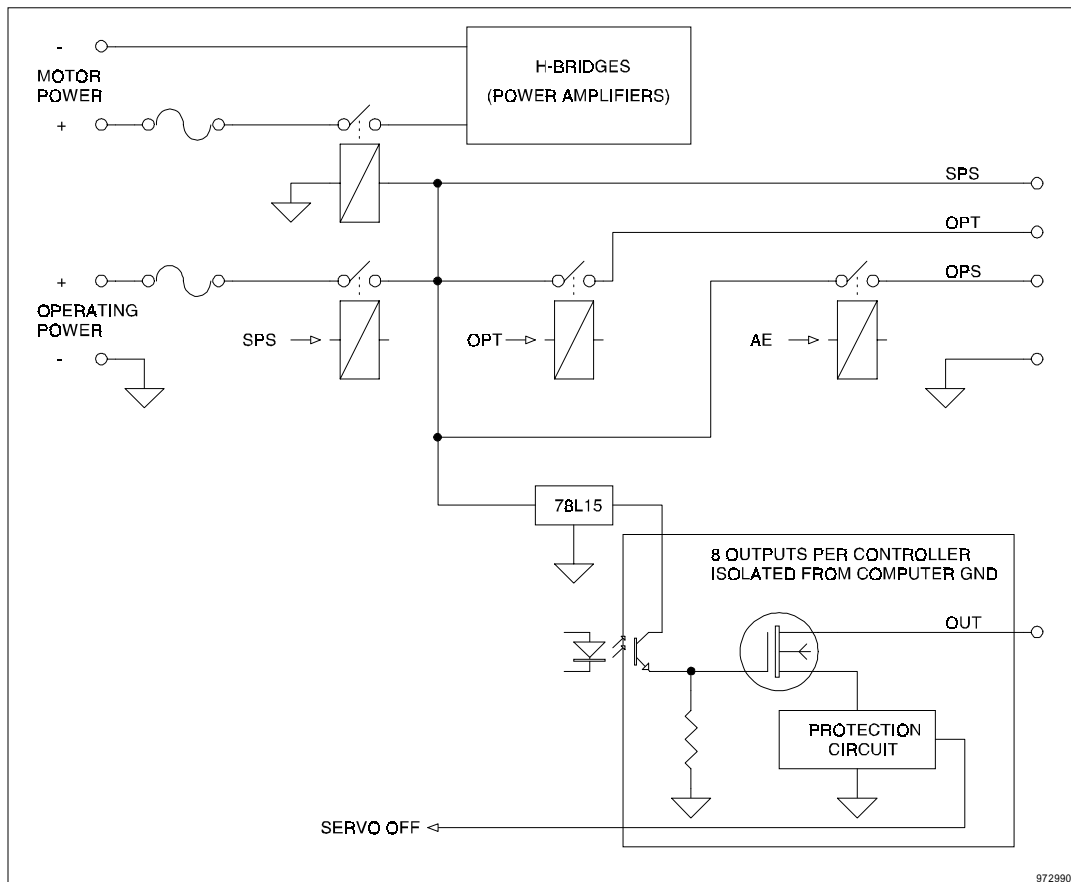

Figure 9: Digital outputs and outbound power sources

The outputs are open collector transistors connected to the ground of the operating voltage. They are optoisolated from computer ground. All outputs are short-circuit protected. If one of them is overloaded, the protection circuit will shut down all transistor outputs. OPT and SPS relays will not be affected. The servo loop will be turned off automatically (amplifier disable) and this will turn off OPS as well. Once activated, the protection keeps outputs disabled until the event that caused the overload exists. The outputs are controlled through register bits OUT0 to OUT7. To activate an output or power supply, the corresponding bit must be set HIGH (1).

	R/W access	D7	D6	D5	D4	D3	D2	D1	D0
Base Addr + 0xA	R/W	AE	RST	OPT	SPS	CL3	CL2	CL1	CL0
Base Addr + 0xD	R/W	OUT7	OUT6	OUT5	OUT4	OUT3	OUT2	OUT1	OUT0

Table 3: Digital Outputs and Outbound Power Registers

Activation of the emergency input will disable SPS. In order to prevent an accidental turn on after the emergency input is activated, SPS is equipped with a double buffered logic. To restore SPS after being shut off, SPS must be cycled off-on, i.e. SPS control bit should be first set LOW (0) and after that set HIGH (1).

Servo Control and Diagnostics Circuit

The Servo Control and Diagnostics circuit (SCD) allows the host to set up the controller and to monitor the current LS-421 status.

■ CONTROLLED SIGNALS

The SCD circuit controls the amplifier enable signal based on several internal and external exception signals. In addition to that, it controls the Motion Processor reset signal. These signals can be monitored or controlled by the AE and RST status/control bits. If AE is set to HIGH (1) the amplifiers are enabled. AE set to LOW (0) means that the amplifiers are disabled.

	R/W access	D7	D6	D5	D4	D3	D2	D1	D0
Base Addr + 0xA	R/W	AE	RST	OPT	SPS	CL3	CL2	CL1	CL0

Table 4: Amplifier Enable Control

The motion processor is in reset when the RST bit is set to HIGH (1). Setting RST to LOW (0) removes reset from the processor.

	R/W access	D7	D6	D5	D4	D3	D2	D1	D0
Base Addr + 0xA	R/W	AE	RST	OPT	SPS	CL3	CL2	CL1	CL0

Table 5: Motion Processor Reset Control

■ MONITORED SIGNALS

Several protection circuits on the LS-421 board generate signals when normal operational conditions are violated. These signals are fed to the SCD circuit, which sets the state of status bits, available to the host for diagnostics. When such an event occurs the amplifier enable signal (and the respective status bit AE) is set LOW (0). This incident will be referred to as *hardware exception*.

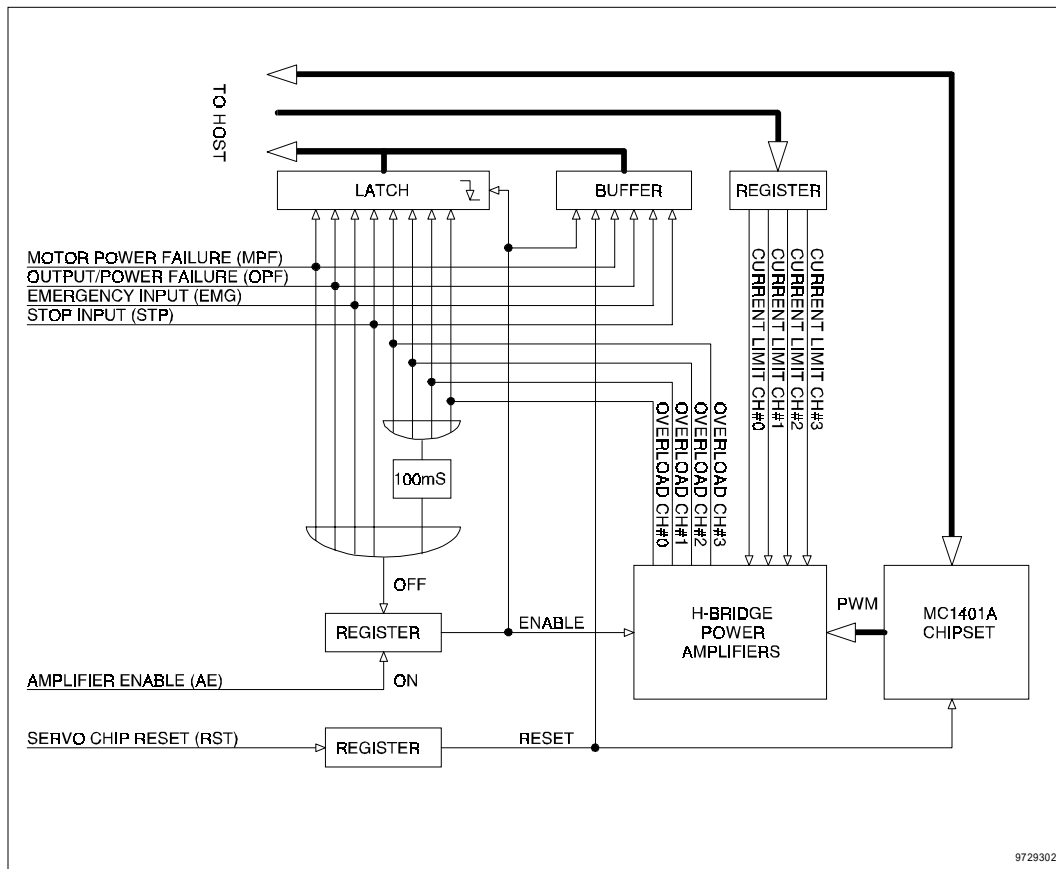

Figure 10: Servo Control and Diagnostics

In addition to the registers, which continuously report the states of some of the exception signals, the SCD circuit controls a latch register, which latches the value of the exception signals at the moment when exceptions occur.

The following exception signals are monitored:

- Motor Power Failure (MPF)
- Output Overload / Output Power Failure (OPF)
- Emergency Input (EMG)
- Stop Input (STP)
- Amplifier Enable (AE)
- MP Reset (RST)

- Motor Current Limit Overload (CL0 to CL3)

■ AMPLIFIER ENABLE (AE)

In case of emergency, power amplifiers must be disabled to protect the controlled equipment and/or the controller itself. When amplifiers are disabled, there is no power on the motor terminals, but encoder feedback continues to function.

LS-421 amplifier enable signal is controlled by Amplifier Enable (AE) bit. Only the host software may set the AE bit HIGH (1). The AE bit can be reset (set LOW (0)) either by the host or automatically by the SCD circuit.

Note

AE bit has a dual meaning. In read mode it represents the status of the amplifiers (enabled or disabled). In write mode, it is a control bit to enable or disable the power amplifiers. The amplifiers of all four servo channels are controlled simultaneously by one AE bit. Thus, amplifiers cannot be enabled or disabled on individual basis.

	R/W access	D7	D6	D5	D4	D3	D2	D1	D0
Base Addr + 0xA	R/W	AE	RST	OPT	SPS	CL3	CL2	CL1	CL0

Table 6: Amplifier Enable control

To activate the amplifier enable signal, AE control bit should be set HIGH (1). Amplifier enable signal is set LOW by either writing logic zero to the AE bit, or automatically when protection circuits are activated and a hardware exception occurs.

Note

For safety reasons, AE is equipped with double buffered logic to prevent an accidental turn on after an emergency shut down.

The same double buffered logic is implemented in the control of SPS. See Digital Outputs and Outbound Power” on page 24. To restore AE after an exceptional event, the AE control bit should be first set LOW (0). Then, setting AE control bit HIGH (1) will enable the amplifiers, if the event that activated the protection circuit is no longer present.

■ MP RESET (RST)

RST bit can be controlled by the software or is automatically set HIGH (1) after the power up or after the hardware reset is issued.

Note

RST bit has a dual meaning. In read mode it represents the status of the motion processor reset signal. In write mode, it is a control bit set or to remove motion processor reset signal.

	R/W access	D7	D6	D5	D4	D3	D2	D1	D0
Base Addr + 0xA	R/W	AE	RST	OPT	SPS	CL3	CL2	CL1	CL0

Table 7: MP Reset control

To put MP in reset state, RST bit must be set HIGH (1). To clear MP reset signal and to enable MP, RST must be set LOW (0).

■ MOTOR POWER FAILURE (MPF)

To power the motors, LS-421 requires a separate power supply isolated from the computer ground and the operating power (24V). If Motor Power is below the undervoltage limit, MPF is set HIGH (1) and AE is automatically disabled. MPF is also set HIGH (1) in case of leakage between high voltage motor circuits and any of the low voltage computer or 24V circuits. A current as low as 0.5mA will trigger the protection. The MPF value is latched in the MPFL bit at the moment when AE turns LOW. The amplifiers have to be previously enabled (AE should be HIGH) in order to latch a value in MPFL when motor power failure occurs. Thus, when amplifiers are disabled a change in the motor power failure condition will be reflected in MPF only but will not affect MPFL.

	R/W access	D7	D6	D5	D4	D3	D2	D1	D0
Base Addr + 0xB	Read	EMG	STP	MPF	OPF	EMGL	STPL	MPFL	OPFL

Table 8: MPF status

■ OUTPUT OVERLOAD / OPERATING POWER FAILURE (OPF)

There are two conditions that can trigger an Operating Power Failure (OPF) event:

- The operating power, required to power the Outputs and Outbound Power Sources is out of range. The operating power required for the Outputs and Outbound Power Sources must be $24V \pm 20\%$. If it is below the prescribed range, the OPF is set HIGH (1) and AE is automatically disabled.
- One or more of the digital outputs is overloaded. All digital outputs are short circuit protected. If any of them is overloaded, all outputs are disabled and OPF is set HIGH (1).

If any of the above conditions occur, amplifiers are disabled and all digital outputs are turned off. To distinguish between the two conditions, the host should first set LOW (0) all outputs and then read the OPF register. If OPF has again a value of 1, this indicates a missing or out of range operating power.

The current OPF value is latched as OPFL at the moment when amplifiers are disabled (AE turns LOW).

	R/W access	D7	D6	D5	D4	D3	D2	D1	D0
Base Addr + 0xB	Read	EMG	STP	MPF	OPF	EMGL	STPL	MPFL	OPFL

Table 9: OPF Status

If the host makes an attempt to enable the power amplifiers by setting HIGH (1) the AE bit, without disconnecting the overloading output or setting its control bit LOW, the protection will not allow that to happen and AE will be instantly reset to LOW (0).

To diagnose which output(s) is overloaded the host must first reset all outputs, i.e. set LOW (0) OUT0 to OUT7 bits. Then, AE should be set HIGH (1) and the outputs should be activated again one by one, by setting the corresponding OUT bits HIGH (1) until the protection is triggered again.

■ EMERGENCY STOP INPUT (EMG)

LS-421 is equipped with emergency stop input. To operate LS-421, a normally closed contact must be connected to that input. Opening the contact will immediately disable the amplifiers and all outputs and will shut off all outbound power sources. For details where to connect an emergency button or other emergency device, see “Interface Connectors” on page 34. In the event of activating the emergency switch, EMG bit is set to one (1) otherwise is reset to zero (0). When amplifiers are disabled (the AE turns LOW), the momentary state of the emergency switch is latched in the EMGL status bit.

	R/W access	D7	D6	D5	D4	D3	D2	D1	D0
Base Addr + 0xB	Read	EMG	STP	MPF	OPF	EMGL	STPL	MPFL	OPFL

Table 10: EMG status

Note

Activating the emergency stop will turn off SPS and will disable all other power sources and outputs.

■ OPTIONAL EMERGENCY STOP INPUTS (STP)

Some of the general purpose inputs or a specified combination of them can be used as an additional emergency stop. This is a custom option and may be installed on user request. It is not supported by default. See “Optional Emergency Stop” Inputs on page 42.

When the option is installed and one or more of the optional emergency stop inputs are activated, STP is set HIGH (1). Under normal conditions STP is LOW (0). STP is continuously available to the host and the current STP value is latched as STPL at the moment when amplifiers are disabled.

	R/W access	D7	D6	D5	D4	D3	D2	D1	D0
Base Addr + 0xB	Read	EMG	STP	MPF	OPF	EMGL	STPL	MPFL	OPFL

Table 11: STP status

■ CURRENT LIMIT VIOLATION (CL0 – CL3)

Current Limit Violation event happens when one or more of the motor power amplifiers make an attempt to exceed their programmed current limits for more than 100 ms¹.

Note

Current Limit Violation event will not be generated when the current limit protection mode is set to “current limitation” and not “shutdown”. The J3 jumper setting controls this mode. See “Current Limit Mode” on page 9.

The current limit protection has two modes of operation depending on J3 jumper setting.

With J3 jumper left open, CL0 – CL3 signals (and respective control bits) will never be set HIGH, regardless of the occurrence of an overload. Motor current though, will be limited to the programmed value.

If J3 jumper is installed, the CL0-CL3 signals (and respective control bits) will be set HIGH whenever an attempt to overload occurs. Even short overloads (under 100 ms) will show up in the CL0-CL3 bits for a limited time. The current though, is always limited to the programmed value. If the overload duration is greater than 100 ms the power amplifiers will be disabled by SCD (Current Limit Violation event will occur).

When AE transitions from HIGH (1) to LOW (0), CL0 to CL3 preserve their values as they were at the moment of failure. This is equivalent to latching the values. By reading the CL register the host can determine which channel was overloaded.

	R/W access	D7	D6	D5	D4	D3	D2	D1	D0
Base Addr + 0xA	Read	AE	RST	OPT	SPS	CL3	CL2	CL1	CL0

Table 12: CL Status

■ SETTING OF AMPLIFIER CURRENT LIMITS

The output of each amplifier is protected against short circuit or overload. The current is constantly monitored and limited (if overload occurs) to a value that can be set individually for each axis.

The current may be limited within the range of 1÷10 A with a 4-bit precision. Only the four MSB are used. Writing 0x00 to the corresponding register sets the current limit to its lowest level (less

¹ The protection will actually limit the current to the programmed value.

than 1A). Writing 0xF0 sets the current limit to its highest level (10A). The value can be fine-tuned using a trimmer-pot (P0, P1, P2, P3), shown in Figure 7.

	R/W access	D7	D6	D5	D4	D3	D2	D1	D0
Base Addr + 0x408	Write	CURRENT LIMIT #0 (0 ÷ 0xF)							
Base Addr + 0x409	Write	CURRENT LIMIT #1 (0 ÷ 0xF)							
Base Addr + 0x40A	Write	CURRENT LIMIT #2 (0 ÷ 0xF)							
Base Addr + 0x40B	Write	CURRENT LIMIT #3 (0 ÷ 0xF)							

Table 13: Current Limit Value Registers

For details on how the Servo Control and Diagnostics circuit handles current limit violations, see “Current Limit Violation” on page 31.

Interrupt Request Lines

In the LS-421 controller architecture there are two sources (signals) that can generate interrupt requests (IRQ) to the host:

- *Amplifier Disable Interrupt (ADI)*. An interrupt request can be generated, each time the amplifiers are disabled.
- *Motion Processor Interrupt (MPI)*. The Motion Processor can generate interrupt request in response to different events.

The states of both interrupt request signals are visible in the ADI and MPI bits, respectively. ADI interrupt request signal may be masked by setting LOW (0) the EN ADI bit in the Interrupt Mask register. There is not a dedicated bit to mask the MPI in the Interrupt Mask register. Only sending appropriate commands to the MP may mask an MP interrupt request.

	R/W access	D7	D6	D5	D4	D3	D2	D1	D0
Base Addr + 0xC	Read	ADI						MPI	
Base Addr + 0xC	Write	EN ADI							

Table 14: IRQ Status and Mask Registers

J2 jumper block selects the interrupt line to the host. IRQ7, IRQ10, IRQ12, IRQ15 may be used. For jumper settings, see “Installation: Interrupt Request Line” on page 8.

Board Identifier

Due to its modular design and adaptable In System Programmable (ISP) architecture, LS-421 motion control board allows quick and easy customizations. To provide information about the current controller configuration, LS-421 features an 8-bit ID number available to the host in ID0 to ID7 registers.

	R/W access	D7	D6	D5	D4	D3	D2	D1	D0
Base Addr + 0x807	Read					ID3	ID2	ID1	ID0
Base Addr + 0xC07	Read					ID7	ID6	ID5	ID4

Table 15: ID registers

The ID for the standard LS-421 configuration is 0xB1.

Interface Connectors

The Base Module supports two interface connectors designated as CN2 and CN3. CN3 connector is the entry port for the external motor and operating power supplies. The emergency stop input is also located there. All digital outputs and outbound power sources are wired to CN2 connector. A block diagram of CN2 and CN3 connectors is shown below.

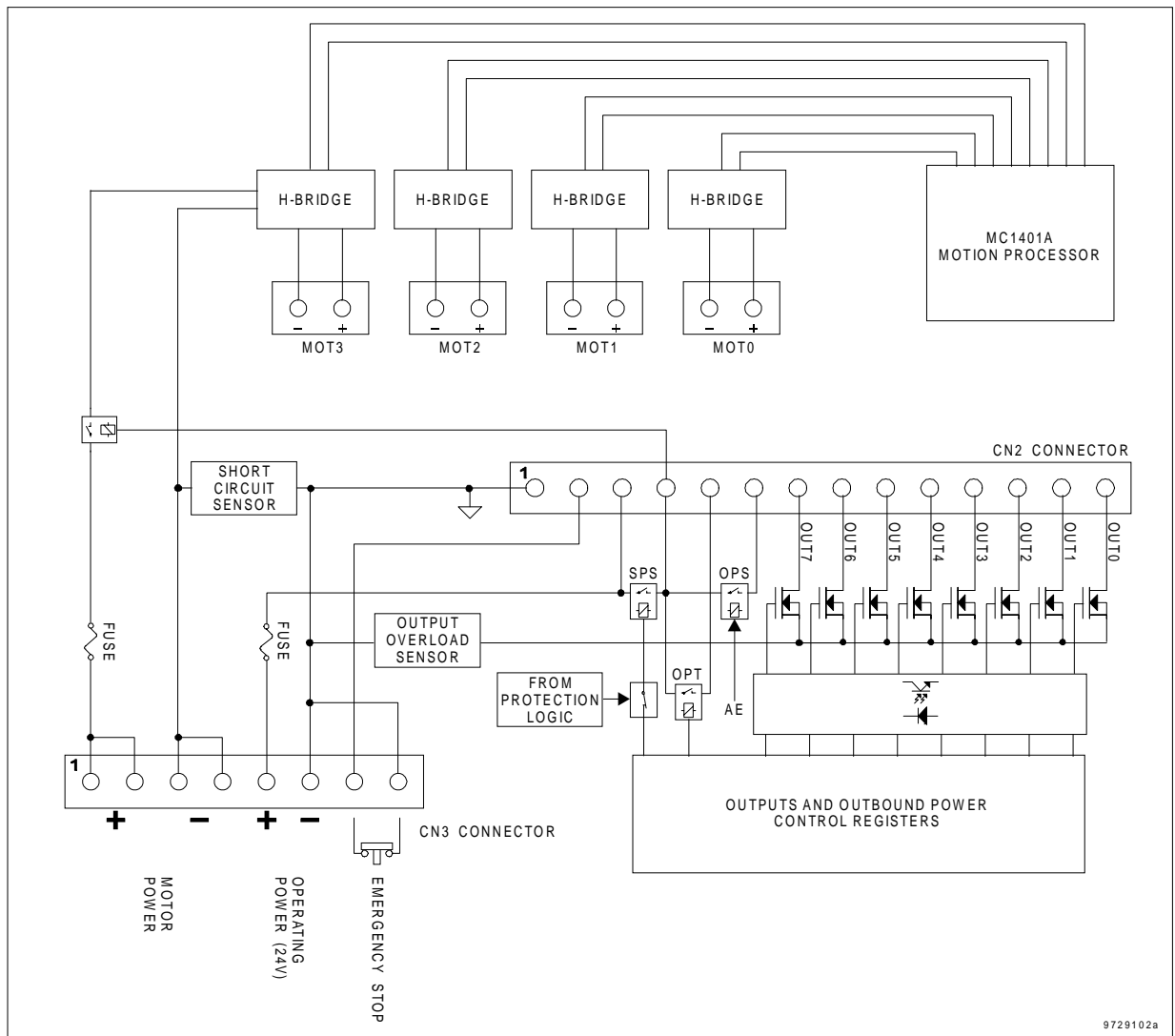

Figure 11: Block Diagram of CN2 & CN3 connectors

■ **CN3 CONNECTOR (EXTERNAL POWER)**

The following figure illustrates the pinout of the CN3 connector and its location on the Base Module.

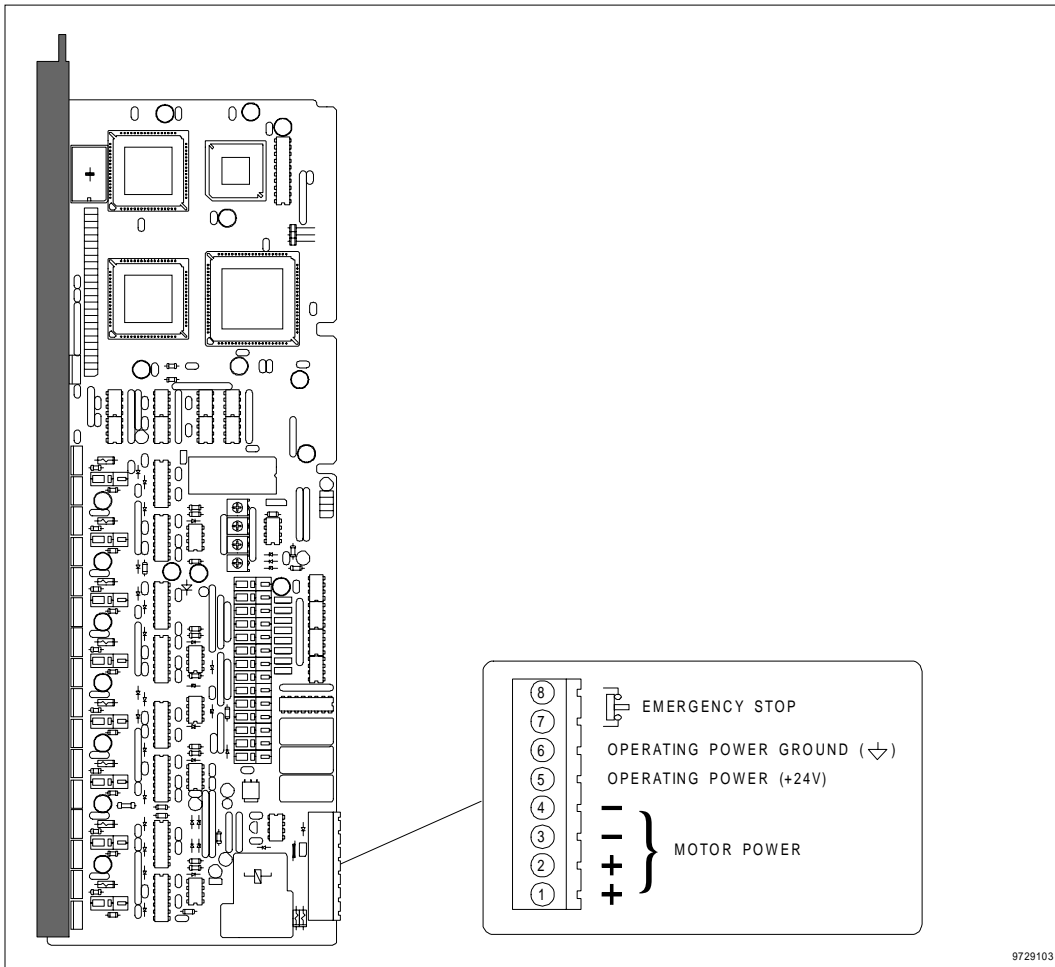

Figure 12: CN3 Connector Location and Pinout

■ CN2 CONNECTOR (OUTPUTS & OUTBOUND POWER)

The following figure illustrates the pinout of the CN2 connector and its location on the Base Module.

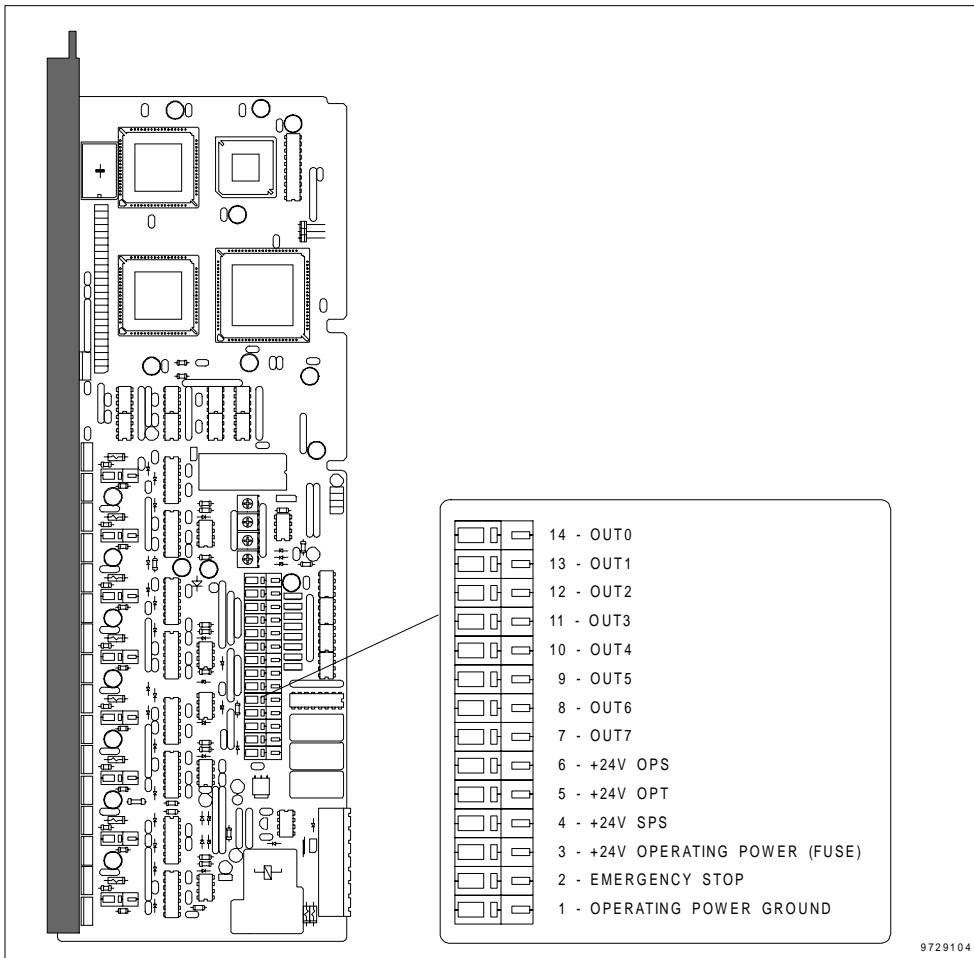

Figure 13: CN2 Connector Location and Pinout

INPUT BOARD

LS-421 is a multipurpose motion controller. To tailor controller I/O features to a broad range of custom applications, all input circuits are located on a separate board, the so-called Input Board (IB). IB is plugged into BM, which serves as a motherboard. A flat ribbon cable connects IB to the controller interface connector, mounted on the front panel.

Note

The front panel connector and the input board may be ordered in different custom designed configurations for specific applications. The standard LS-421 Input Board is LS-421-2112.

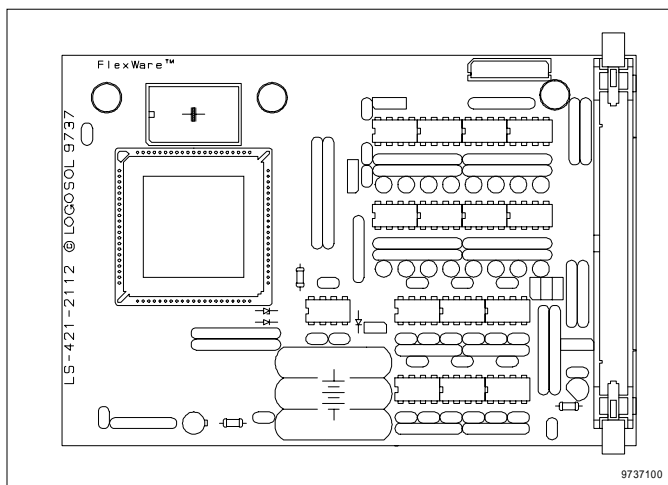

Figure 14: LS-421-2112 Input Board Layout

Input Board LS-421-2112 features:

- 16 general-purpose digital optoisolated inputs. Two of the inputs may be alternatively used as absolute position encoder inputs.
- Optoisolated interface and power supply for up to 4 incremental encoders
- 4-channel optoisolated receiver, power supply and backup battery for up to 4 multi-turn absolute position encoders. Two of the channels overlap two of the general-purpose digital optoisolated inputs and may be alternatively used as such.
- All input lines and encoder signals are processed by In System Programmable (ISP) logic device for maximum flexibility

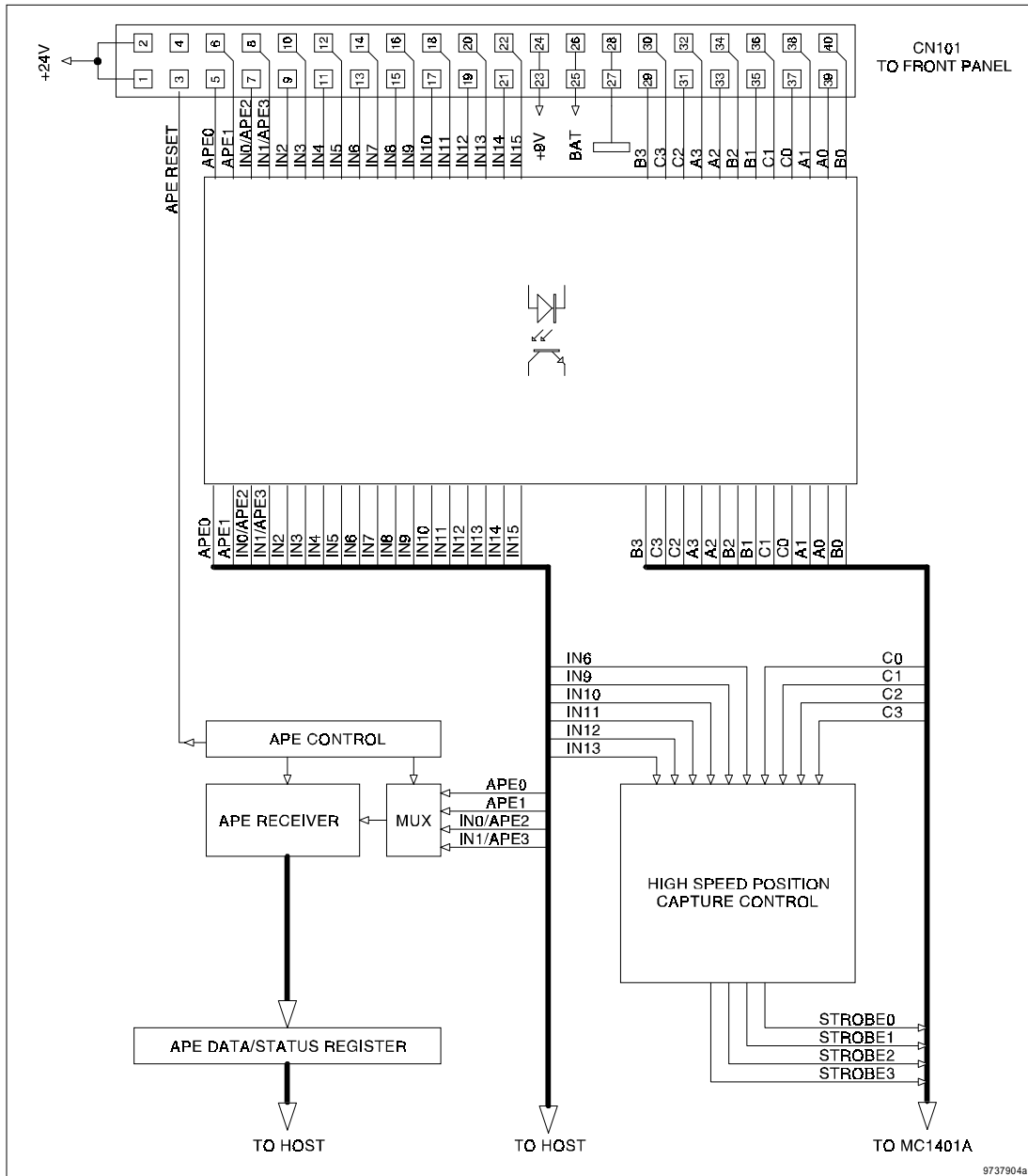

Figure 15: LS-421-2112 Input Board Block Diagram

Digital Optoisolated Inputs

All 16 inputs IN0÷IN15 may be used as general-purpose inputs, although some of them may have additional functions. Six may serve as strobes for high speed position capturing. IN0/APE2 and IN1/APE3 may be used as inputs for two additional multi-turn absolute position encoders. APE0 and APE1 are dedicated as inputs for two multi-turn absolute position encoders.

■ GENERAL PURPOSE INPUTS

The optoisolated inputs are designed to work with open collector or contact sensors.

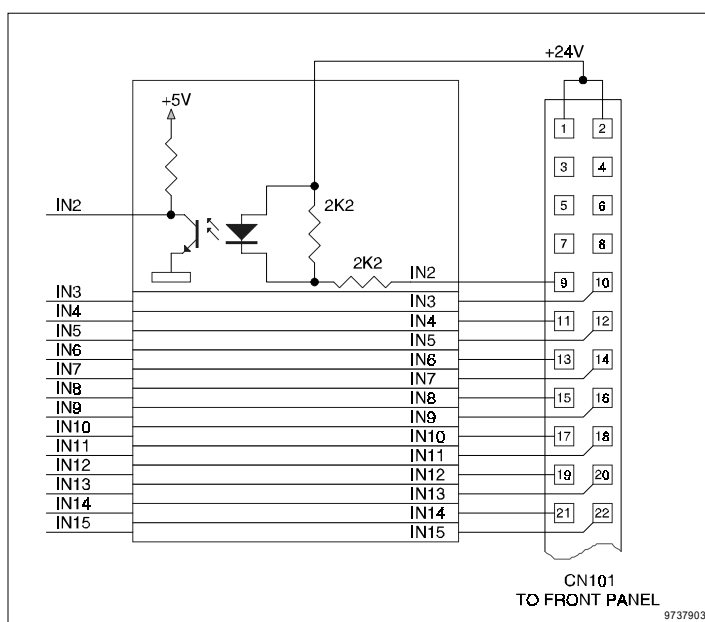

Figure 16: General purpose inputs

On LS-421-2112 input board the operational power is used to power the inputs. The corresponding sensor should be connected between the input and the operating power ground (for the standard interface wiring the operating power ground is at pin W).

Note

The sensor should be able to sink 10mA @ 24V in order to activate the input.

The host can check inputs state reading the input register bits IN0 to IN15. When an input is activated (there is current) the state of the corresponding bit is LOW (0).

	R/W access	D7	D6	D5	D4	D3	D2	D1	D0
Base Addr + 0x8	Read	IN7	IN6	IN5	IN4	IN3	IN2	IN1	IN0
Base Addr + 0x9	Read	IN15	IN14	IN13	IN12	IN11	IN10	IN9	IN8

Table 16: Input Registers

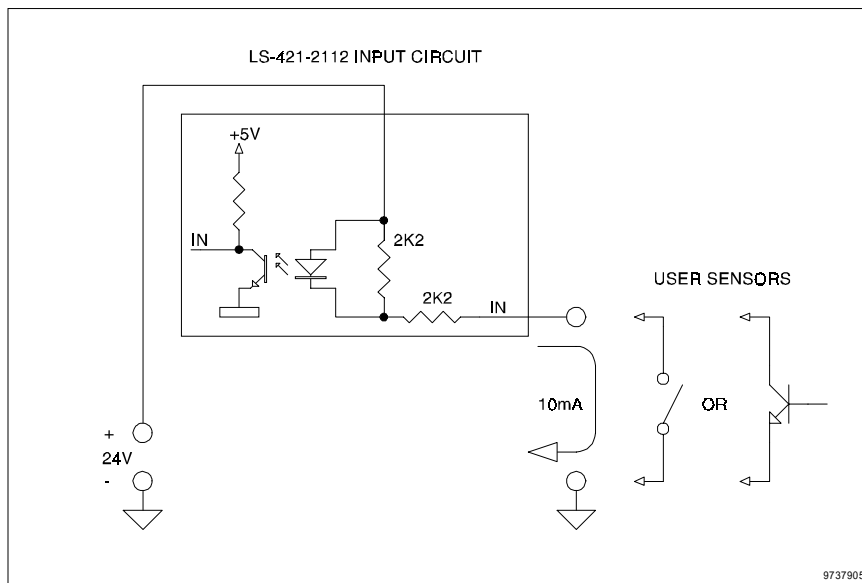

Figure 17: LS-421 Input Connection Diagram

■ ABSOLUTE POSITION ENCODER INPUTS

APE0, APE1, IN0/APE2, IN1/APE3 are designed to work as data inputs for multi-turn Absolute Position Encoders (APE). All four inputs use +5V power supply. IN0/APE2, IN1/APE3 have dual function. If not connected to an APE, IN0/APE2 and IN1/APE3 may be used as general purpose inputs (with +5V power supply). When connected to an APE, IN0/APE2 and IN1/APE3 oscillate HIGH-LOW reflecting the signal levels resulting from the serial communication with the APE over that line.

Note

To activate APE0, APE1, IN0/APE2, IN1/APE3, the load should be able to sink 20mA @ 5V.

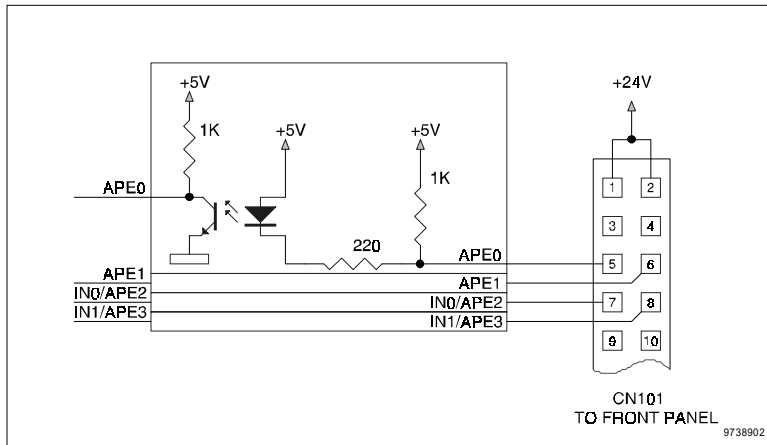

Figure 18: Multi-Turn Absolute Position Encoder (APE) Inputs

■ HIGH SPEED POSITION CAPTURE INPUTS

The Motion Processor is able to record the absolute motor position using the encoder index line as a strobe. See MC1401A manual for information how to use position capture mode. LS-421 is equipped with special circuitry, which allows using some of the controller inputs as position strobes, in place of the encoder index signal. The following inputs may be used to this purpose: IN2, IN5, IN6, IN7, IN8 or IN9.

Note:

With IB LS-421-2112 the selected strobe input becomes the common strobe for all four servo controlled motion axes.

The host may control which one of IN2, IN5, IN6, IN7, IN8 or IN9 to serve as a strobe by writing a coded value to the Position Capture Select registers (PCS0 to PCS3).

	R/W access	D7	D6	D5	D4	D3	D2	D1	D0
Base Addr + 0xE	Write	PCS3	PCS2	PCS1	PCS0				APE RES

Table 17: PCS control registers

Either low (input is closed to the ground) or high (input is open) level may be selected to trigger the capture. For LS-421-2112 selected strobe input is common for all four axes. For homing purposes, row 14 or 15 from the table bellow should be selected. This will allow each axis to capture the motor position using its own encoder index signal.

#	PCS3	PCS2	PCS1	PCS0	Channel#0	Channel#1	Channel#2	Channel#3	Act. level
0	0	0	0	0	IN6	IN6	IN6	IN6	Low
1	0	0	0	1	IN6	IN6	IN6	IN6	High
2	0	0	1	0	IN7	IN7	IN7	IN7	Low
3	0	0	1	1	IN7	IN7	IN7	IN7	High
4	0	1	0	0	Reserved	Reserved	Reserved	Reserved	-
5	0	1	0	1	Not used	Not used	Not used	Not used	-
6	0	1	1	0	IN2	IN2	IN2	IN2	Low
7	0	1	1	1	IN2	IN2	IN2	IN2	High
8	1	0	0	0	IN5	IN5	IN5	IN5	Low
9	1	0	0	1	IN5	IN5	IN5	IN5	High
10	1	0	1	0	IN8	IN8	IN8	IN8	Low
11	1	0	1	1	IN8	IN8	IN8	IN8	High
12	1	1	0	0	IN9	IN9	IN9	IN9	Low
13	1	1	0	1	IN9	IN9	IN9	IN9	High
14	1	1	1	0	Index#0	Index#1	Index#2	Index#3	Low
15	1	1	1	1	Index#0	Index#1	Index#2	Index#3	Low

Table 18: Selecting Strobe Inputs

OPTIONAL EMERGENCY STOP INPUTS

In some customized configurations, one or more of general-purpose inputs may be used as additional emergency stops.

Note

The standard version of LS-421-2112 does not support this option.

In a customized version of LS-421-2112 (part number 920420422) IN2, IN3, IN4, IN5 are configured as additional emergency stop inputs. All four inputs must be in active state (connected to the operating power ground) to enable the power amplifiers (see Figure 19). If one or more of the optional emergency stop inputs is disconnected from the operating power ground, the power amplifiers are automatically disabled and the Output Power Supply (OPS) is switched off.

STP bit in the status register is set HIGH (1) if at least one of the optional emergency stop inputs is left open. The value of STP is latched in STPL during AE transition HIGH to LOW. See “Optional Emergency Stop Inputs” on page 30.

The following figure shows a simple application of optional emergency stop inputs (as 4 normally closed buttons) and their wiring to the front-panel connector.

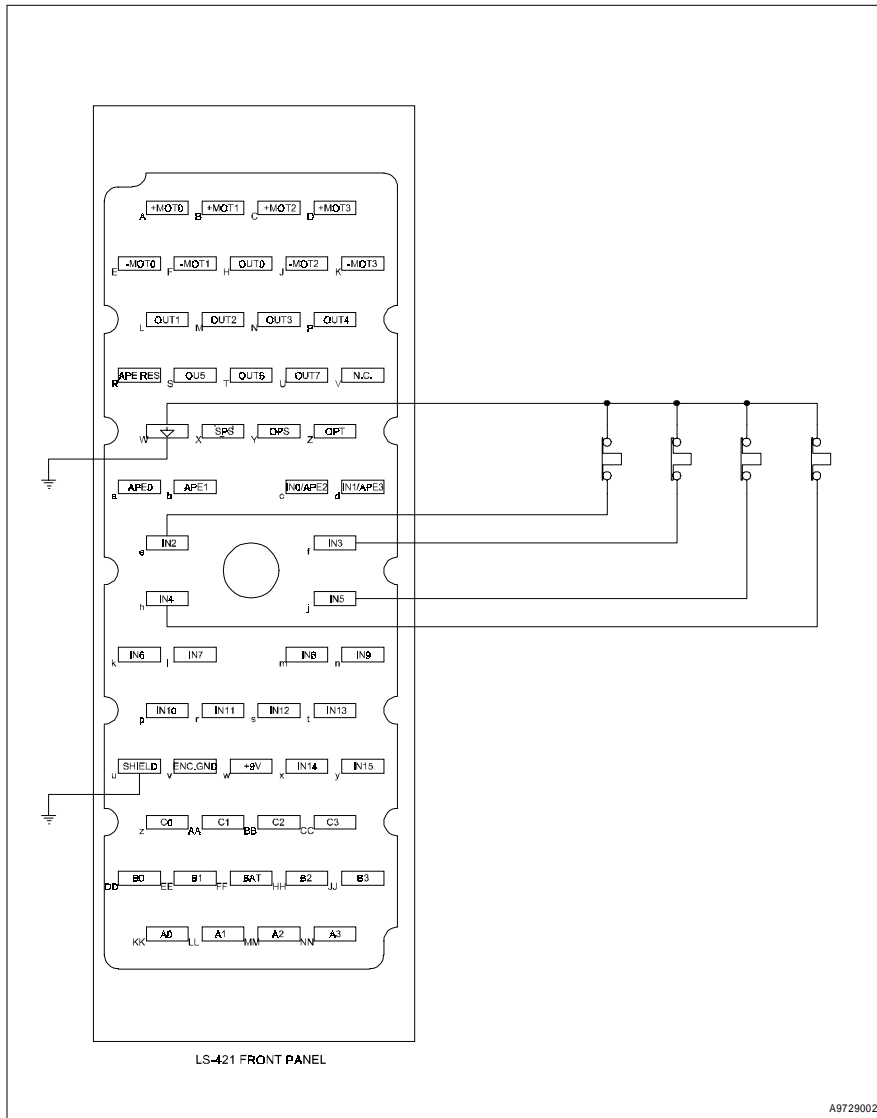

Figure 19 Optional Emergency Stop Inputs Wiring

Incremental Encoder Interface

LS-421-2112 input board is designed to work with quadrature incremental encoders with index pulse. Encoders must be equipped with open collector outputs or line drivers capable to sink 20mA@5V. Medium-speed HP2531 optocouplers are used to provide 20mA current loop for increased noise immunity. LS-421-2112 receivers are rated for speeds up to 1,000,000 encoder counts per second.

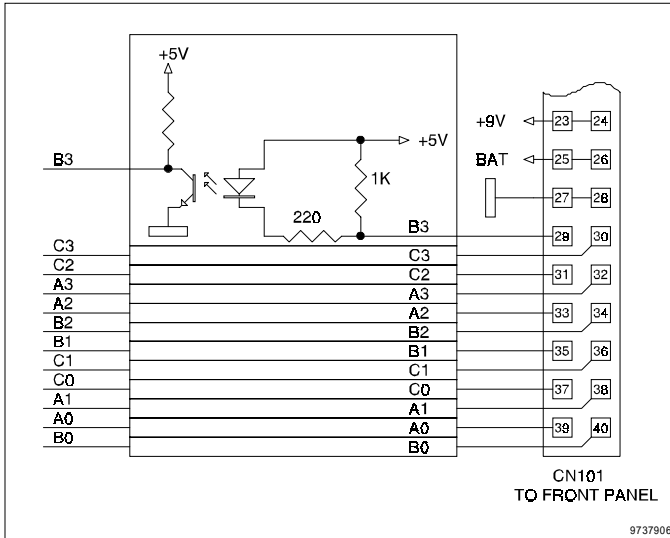

Figure 20: Incremental Encoder interface

To prevent voltage drop across long interface cables, LS-421 provides +9V for encoder power. An additional voltage regulator (7805) is required. It should be located close to the encoders.

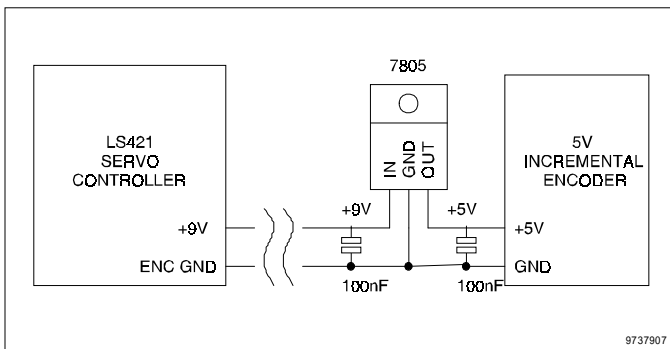

Figure 21: Encoder Power Supply

Multi-turn Absolute Encoder Receiver

LS-421-2112 is designed to operate with up to four multi-turn absolute position encoders (APE). The following types, manufactured by Tamagawa Seiki Co are supported:

- SA35-11/24bit-LPS-5V
- SA56-11/24bit-LPS-5V

SA35/56 series encoders consist of two modules – incremental and absolute, which function simultaneously and independently of each other.

The incremental module functions as a standard incremental encoder. It should be connected to LS-421-2112 incremental encoder interface. See “Incremental Encoder Interface” on page 43. Data from the SA35/56 incremental encoder is received and processed by the Motion Processor.

The absolute module in SA35/56 constantly transmits serial data consisting of 24-bit absolute position and 6-bit status over the corresponding input line (APE0, APE1, IN0/APE2, IN1/APE3). See “Absolute Position Encoder Inputs” on page 40. Manchester code with 3-bit CRC is used. Received data is decoded, checked for errors and stored in 24-bit data register and 6-bit status register, available to the host.

The receiver works on request. Typically, it is in standby mode and waits for the next request command. All four multi-turn absolute encoders share a single register for 24-bit position data and 6-bit status. By writing to one of the four request registers (REQ APE#0 to REQ APE#3) the host selects one of the encoder inputs APE0, APE1, IN0/APE2, IN1/APE3 and enables the receiver. This also sets LOW (0) the APE RDY flag.

Once APE RDY flag turns HIGH, APE data and status are valid and may be read by the host. The data is available in the APE DATA register, bits 0 to 23, where 23 is the MSB. The minimal time to complete the request is 67÷109 μ s. In noisy environment this time may increase. If the receiver detects an error, it will discard received data and automatically start new acquiring procedure. In most cases the request will be completed for less than 1 ms.

The host is responsible for reading the absolute position from the encoder interface and setting it as actual position to the MP.

	R/W access	D7	D6	D5	D4	D3	D2	D1	D0
Base Addr + 0x404	Write	REQ APE#0							
Base Addr + 0x405	Write	REQ APE#1							
Base Addr + 0x406	Write	REQ APE#2							
Base Addr + 0x407	Write	REQ APE#3							

Table 19: APE request registers

	R/W access	D7	D6	D5	D4	D3	D2	D1	D0
Base Addr + 0x404	Read	APE D7	APE D6	APE D5	APE D4	APE D3	APE D2	APE D1	APE D0
Base Addr + 0x405	Read	APE D15	APE D14	APE D13	APE D12	APE D11	APE D10	APE D9	APE D8
Base Addr + 0x406	Read	APE D23	APE D22	APE D21	APE D20	APE D19	APE D18	D17	APE D16
Base Addr + 0x407	Read	APE RDY		BE	OF	OS	BA	PS	CE

Table 20: APE Data & Status Registers

The following is a brief description of the abbreviations used in Table 20.

APE RDY	APE ready flag. If READY=1, data and status are valid. If READY=0, data acquiring is in progress.
APE D23 ÷ D0	Multi-turn absolute position encoder data
CE	Counter error status
PS	Pre-load status
BA	Battery alarm
OS	Over-speed
OF	Over-flow
BE	Battery error

The supported absolute position encoders must be reset if disconnected or when an error occurs (e.g. over-speed and over-flow). To reset the encoder the RES control bit must be set HIGH (1) and held in that state for at least 4÷5 sec. To enable the absolute position encoders, RES should be kept LOW (0).

	R/W access	D7	D6	D5	D4	D3	D2	D1	D0
Base Addr + 0xE	Write	PCS3	PCS2	PCS1	PCS0				RES

Table 21: APE reset control bit

SA35/56 multi-turn absolute encoders require an external battery backup to maintain the absolute motor position when the main power is off. A fully charged LS-421-2112 on-board battery is capable to power four SA35 encoders for a minimum of 150 hours. During normal operation the battery is recharged automatically.

A sample application using absolute position encoders is shown on the following figure.

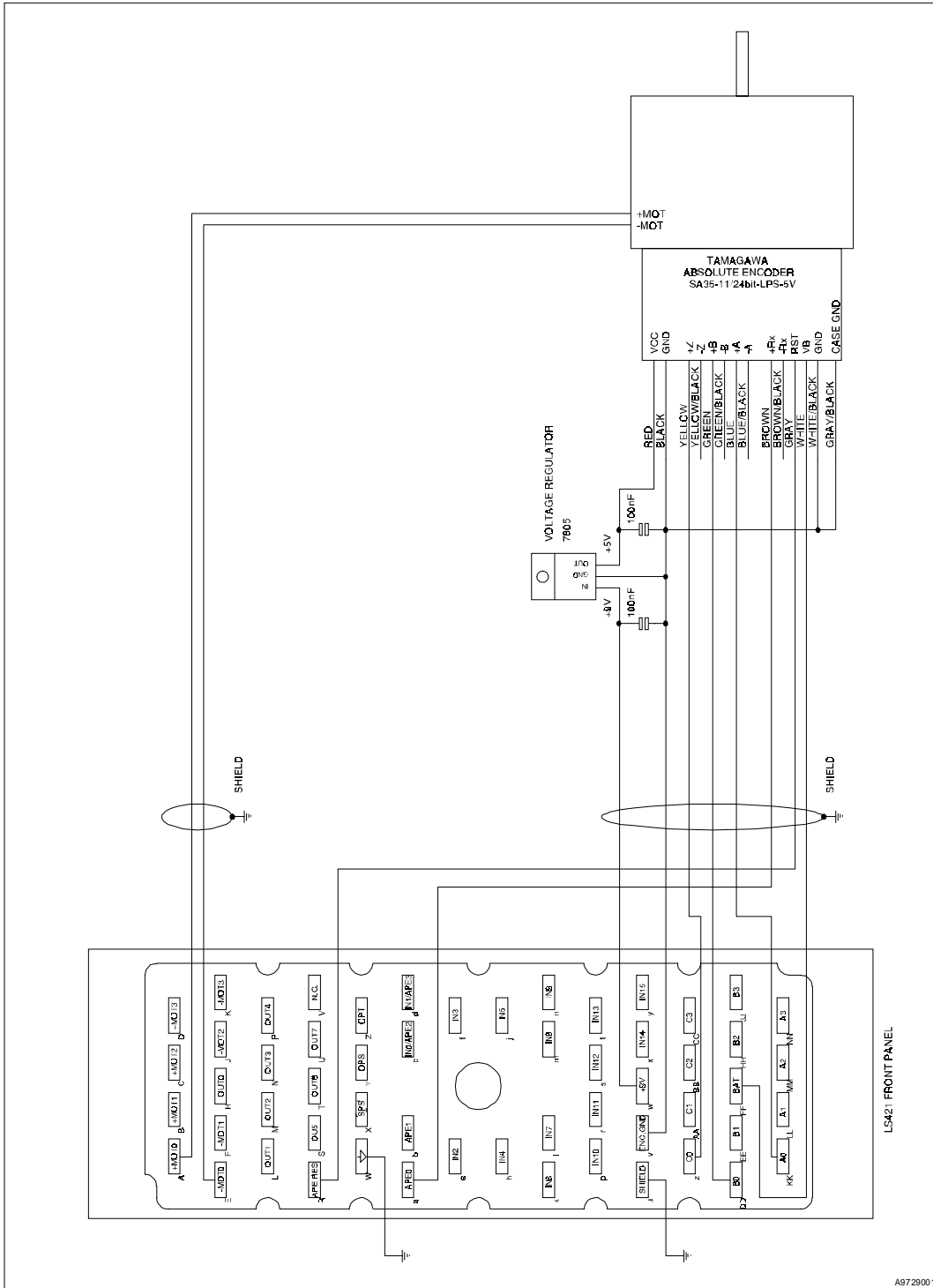

Figure 22: Multi-turn absolute encoder sample wiring

INTERFACE WIRING

LS-421 may be equipped with different interface connectors. To allow fast and easy customization to user-defined interface and pinout, the interface connector is designed as a separate module. It is mounted on the front panel and is connected to the controller with a special cabling (user harness). The LS-421 standard interface wiring is shown below.

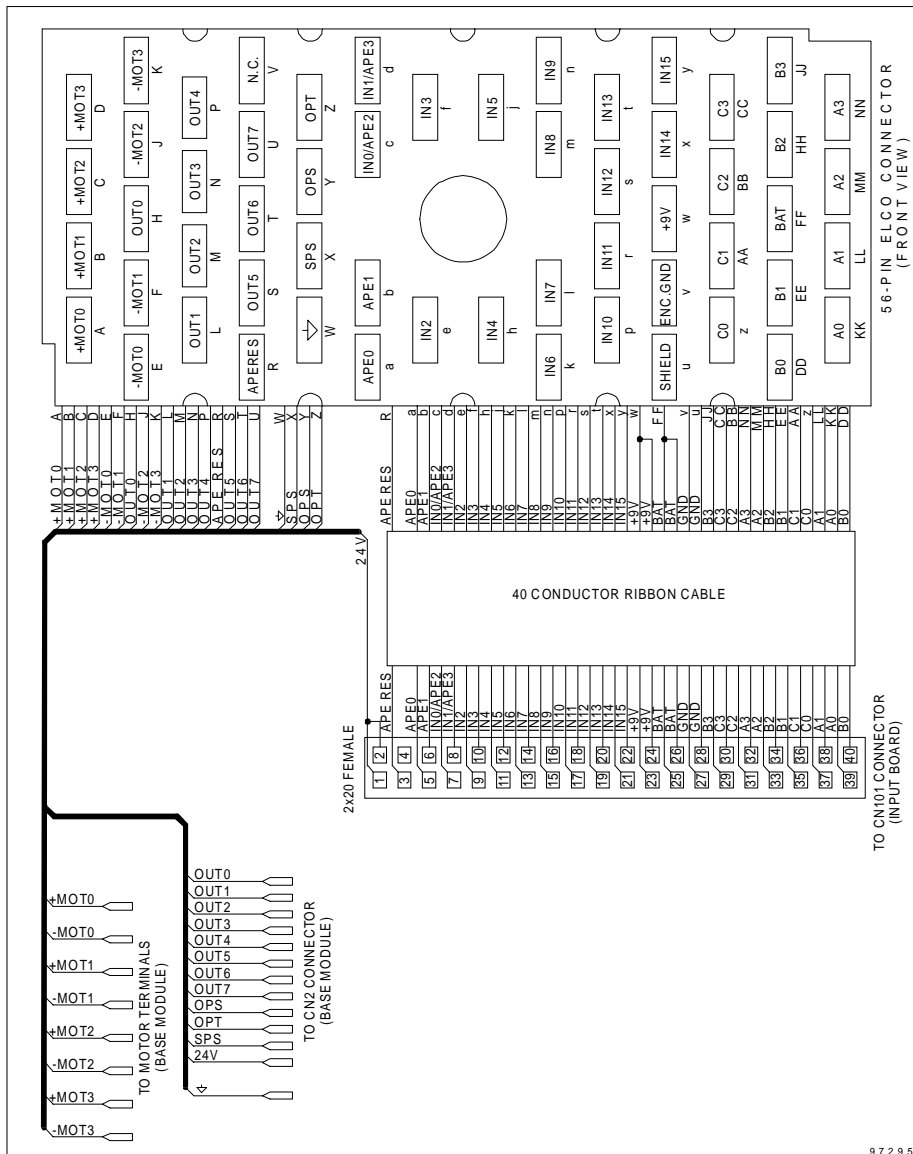

Figure 23: Standard Interface Wiring

EXTERNAL POWER SUPPLY

LS-421 motion controller requires two external power supplies:

- Operating power (24V DC)
- Motor power (24÷80V DC).

The motor power supply is used to drive the motors only. The operating power supply is used to power the onboard input and output circuits and, optionally, to power the sensors and other circuits in the controlled system.

Caution

Motor power supply should be floating. This is required for the proper operation of the protection circuits. If this requirement is not met the LS-421 controller and/or the user equipment may be damaged when the motor terminals are shortened or wrongly wired.

CN3 connector is the entry point for the external power supplies. Also, the emergency stop input is connected there. The schematics of a typical power supply for LS-421 is shown below.

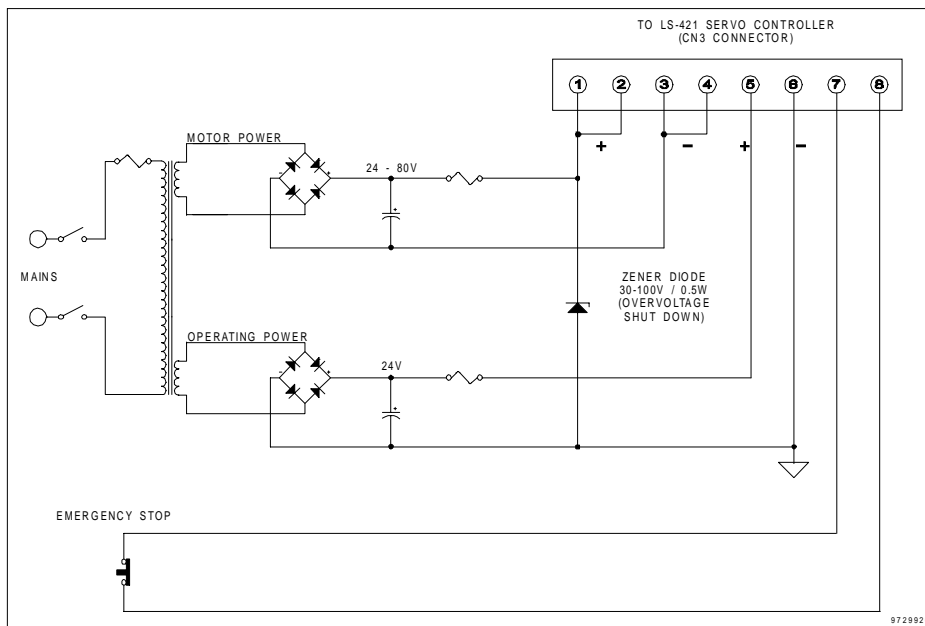

Figure 24: Typical power supply

IV. Basic Control Procedures

This section shows algorithm flow charts for some common control procedures:

- Board Identification
- Board Initialization and Power On
- Enable Amplifiers
- Disable Amplifiers
- Diagnostics

Board Identification

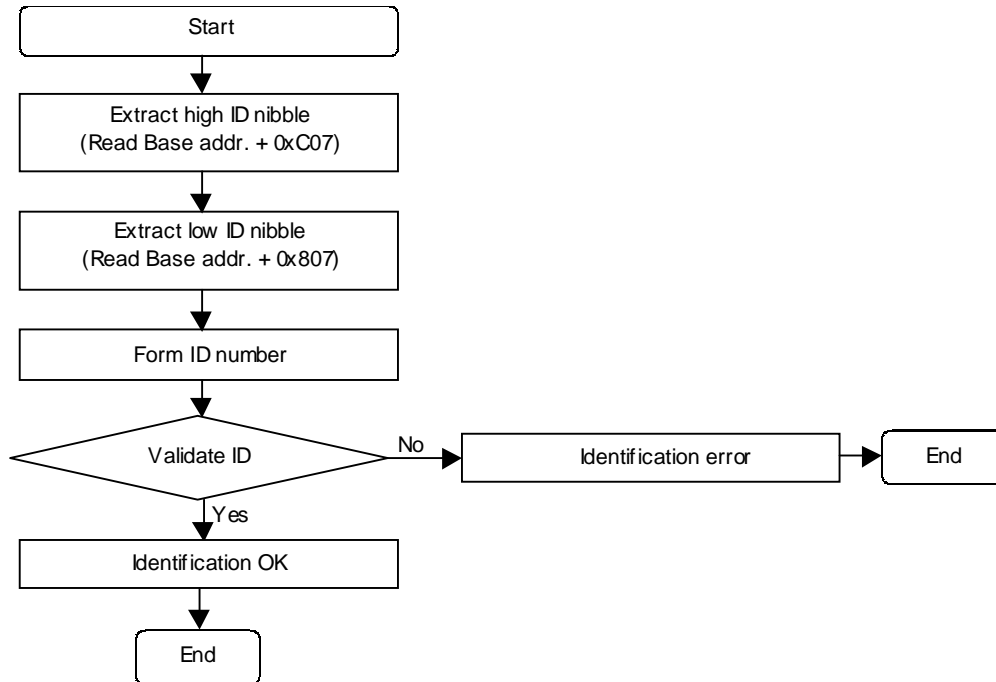

Board Initialization and Power On

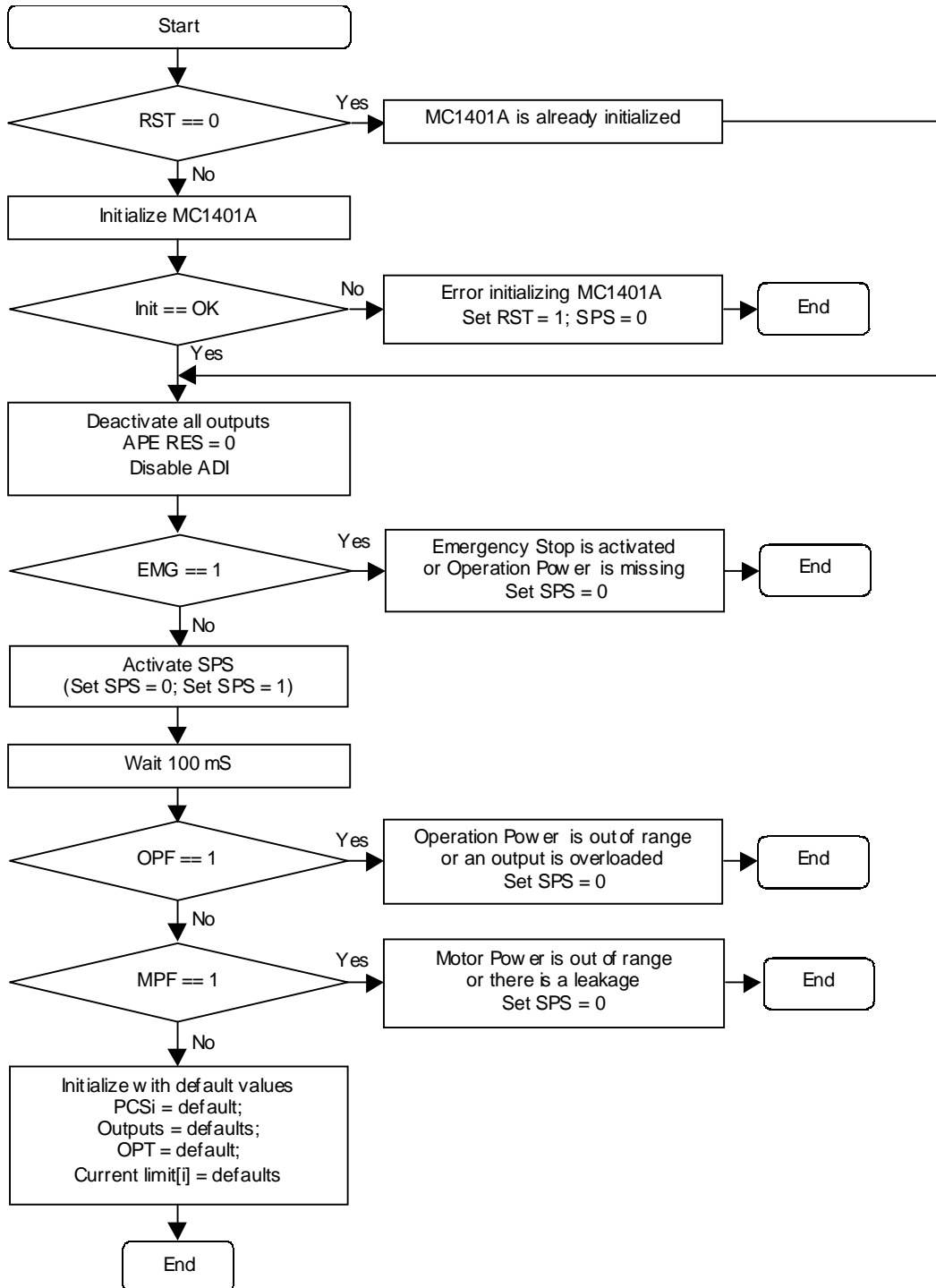

Enable Amplifiers

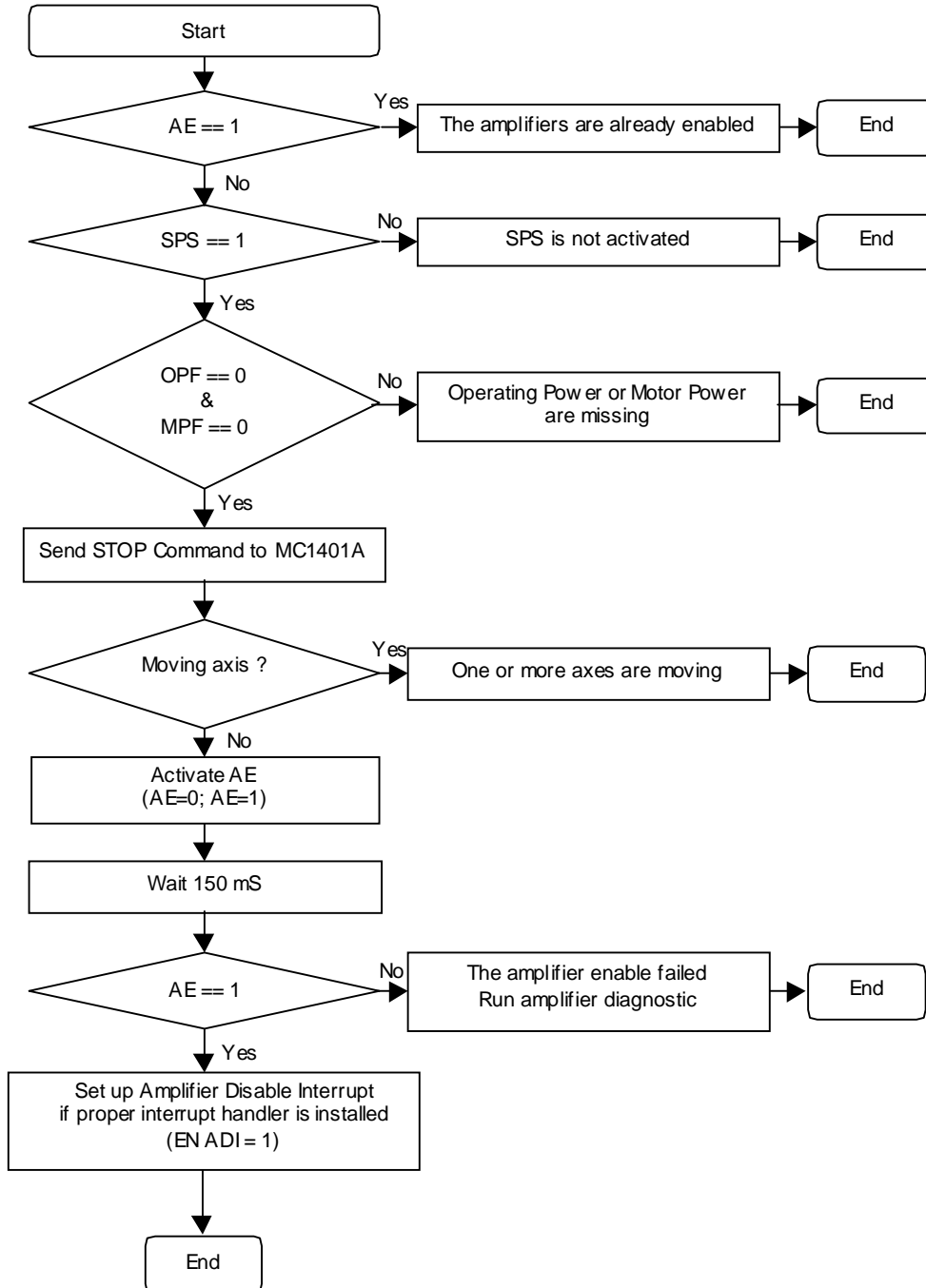

Disable Amplifiers

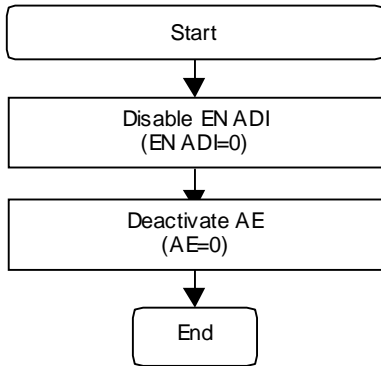

Diagnostics

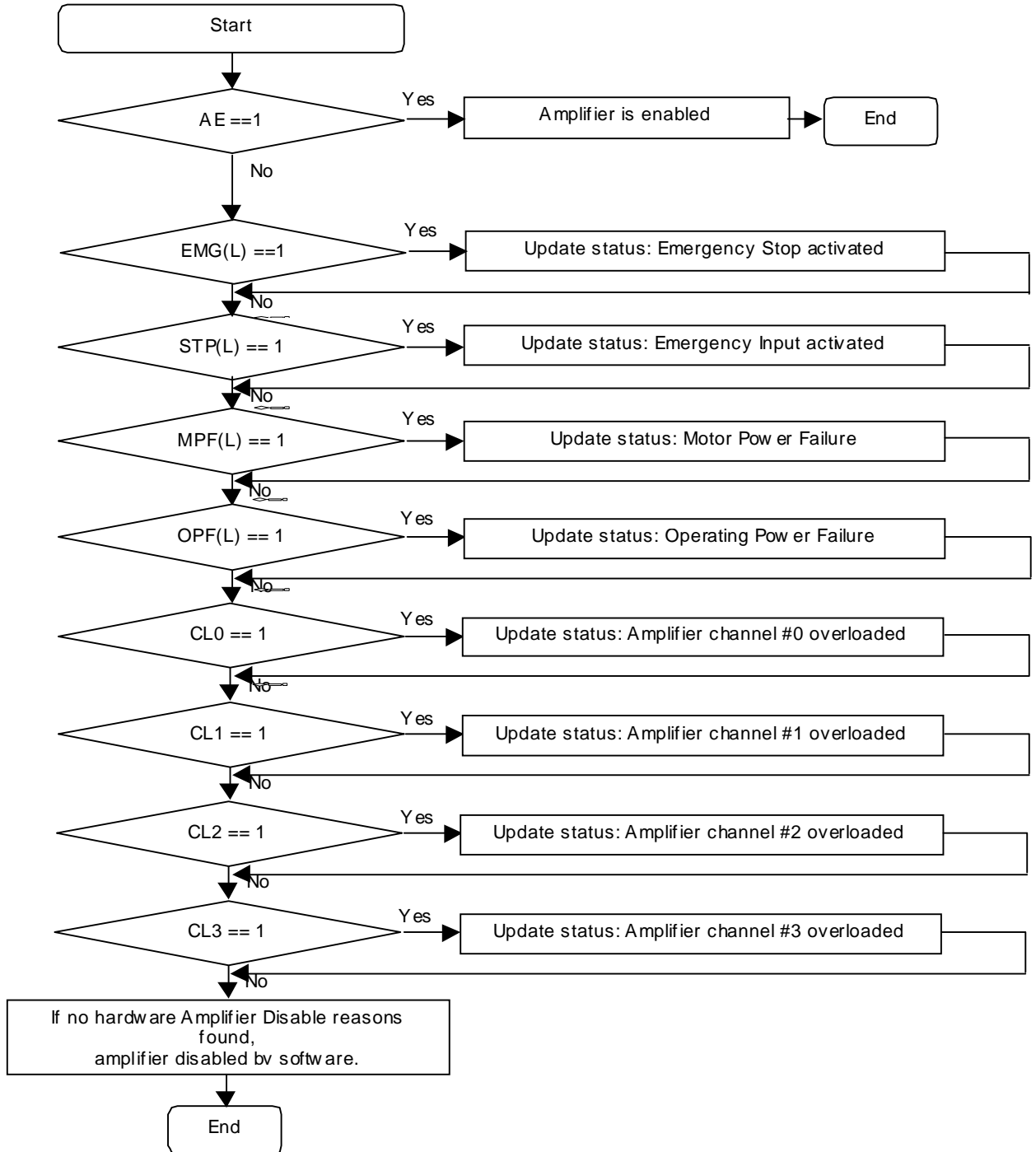

V. Appendix A

□ TECHNICAL SPECIFICATION

Basic Features

- 4 servo controlled motion axes
- Modular design
- Bus interface: ISA
- DSP technology based on PMD MC1401A chip
- ± 10 -bit PWM @ 25KHz
- S-curve velocity profile
- Programmable output current limit/shut down
- Quadrature incremental encoder interface (encoder power supply provided)
- Multi-turn absolute position encoder interface (power and backup supply provided)
- Additional general purpose optoisolated inputs and outputs
- Flexible wiring
- Emergency stop input

Motion Control

Motion Control	Characteristics
Motor Output	
PWM resolution	±10 bit
PWM switching frequency	25 kHz
min load inductance	200μH
typical motor power supply voltage range	24÷80 VDC
undervoltage shutdown	18 VDC
overvoltage shutdown	100 VDC
max continuous current per channel	8.5A
max short term current per channel (t < 10 sec)	10A
max continuous current per board	16A
programmable current limit for each channel	2-10A
Encoder	
type	incremental A, B, Z
max pulse frequency	1 MHz
optoisolated encoder inputs	20mA@5V

Digital I/O lines

Digital Inputs and Outputs	Characteristics
14 general-purpose optoisolated digital inputs	24V/10mA
/6 of the inputs may serve as high speed position capture strobes/	
8 open collector outputs with short circuit protection	
max output voltage	48V
max current per output	1A
max current per board	5A
3 relay controlled 24 V power supplies	
relay type	OMRON G6B
max current	5A/30V DC
contact resistance	30mΩ
mechanical contact reliability	20 x 10 ⁶

Power Requirements

Power Supply	Characteristics
computer power supply	+5V ± 5% / 1A
	+12V ± 5% /1A
external operating power	24V DC ± 20%
external motor power	24÷80V DC

VI. Appendix B: Memory Map

LS-421 is designed as a standard ISA bus peripheral device. To save I/O space, LS-421 uses only 16 bytes from the lowest 1024 I/O addresses range. The rest of LS-421 registers occupy the space located at offset 0x400, 0x800 and 0xC00. For instance, if LS-421 base address is set to 0x280, the following I/O address are in use – 0x280÷0x28F, 0x680÷0x68F, 0xA80÷0xA8F, 0xE80÷0xE8F. Eight base addresses are available, depending on J1 setting – 0x280, 0x1280, 0x2280, 0x3280, 0x2A0, 0x12A0, 0x22A0, 0x32A0. The table below shows LS-421 registers location relatively to controller base address. The offsets are in hexadecimal notation.

READ									WRITE									
D7	D6	D5	D4	D3	D2	D1	D0		D7	D6	D5	D4	D3	D2	D1	D0		
MC1401A DATA REGISTER									MC1401A DATA REGISTER									
READY									MC1401A COMMAND REGISTER									
0								0									0	
1								1									1	
2								2									2	
3								3									3	
4								4									4	
5								5									5	
6								6									6	
7								7									7	
8	IN7	IN6	IN5	IN4	IN3	IN2	IN1	IN0	8								8	
9	IN15	IN14	IN13	IN12	IN11	IN10	IN9	IN8	9								9	
A	AE	RST	OPT	SPS	CL3	CL2	CL1	CL0	A	AE	RST	OPT	SPS				A	
B	EMG	STP	MPF	OPF	EMGL	STPL	MPFL	OPFL	B								B	
C	ADI						MPI		C	ENADI							C	
D	OUT7	OUT6	OUT5	OUT4	OUT3	OUT2	OUT1	OUT0	D	OUT7	OUT6	OUT5	OUT4	OUT3	OUT2	OUT1	OUT0	D
E									E	PCS3	PCS2	PCS1	PCS0				APERES	E
F									F									F
400									400									400
401									401									401
402									402									402
403									403									403
404	APE D7	APE D6	APE D5	APE D4	APE D3	APE D2	APE D1	APE D0	404								REQ APE#0	404
405	APE D15	APE D14	APE D13	APE D12	APE D11	APE D10	APE D9	APE D8	405								REQ APE#1	405
406	APE D23	APE D22	APE D21	APE D20	APE D19	APE D18	APE D17	APE D16	406								REQ APE#2	406
407	APE RDY		BE	OF	OS	BA	PS	CE	407								REQ APE#3	407
408									408								CURRENT LIMIT #0 (0x0 - 0xF)	408
409									409								CURRENT LIMIT #1 (0x0 - 0xF)	409
40A									40A								CURRENT LIMIT #2 (0x0 - 0xF)	40A
40B									40B								CURRENT LIMIT #3 (0x0 - 0xF)	40B
40C									40C									40C
40D									40D									40D
40E									40E									40E
40F									40F									40F
807				ID3 = 0	ID2 = 0	ID1 = 0	ID0 = 1	807										807
C07				ID7 = 1	ID6 = 0	ID5 = 1	ID4 = 1	C07										C07

Table 22: LS-421 Memory Map

LOGOSOL

Logosol, Inc.
1155 Tasman Drive
Sunnyvale, CA 94089
USA

Tel: (408) 744 0974
Fax: (408) 744 0977
[Http://www.logosolinc.com](http://www.logosolinc.com)

Document No 710420103
© 1999 Logosol, Inc.
Printed in USA