

ACCU ELECTRIC MOTORS INC

USA: (888) 932-9183

CANADA: (905) 829-2505

- ✓ Over 100 years cumulative experience
- ✓ 24 hour rush turnaround / technical support service
- ✓ Established in 1993



The leading independent repairer of servo motors and drives in North America.

Visit us on the web:

www.servo-repair.com

www.servorepair.ca

www.ferrocontrol.com
www.sandvikrepair.com
www.accuelectric.com

Scroll down to view your document!

For 24/7 repair services :

USA: 1 (888) 932 - 9183

Canada: 1 (905) 829 -2505

Emergency After hours: 1 (416) 624 0386

Servicing USA and Canada

STEPPING MOTORS

GEAR BOX

BRAKE

ENCODER

UP TO IP68

SPECIAL VERSIONS



stögra
ANTRIEBSTECHNIK GMBH

www.stoegra.de



○ **DRIVING**

○ **MOTION CONTROLING**

○ **POSITIONING**

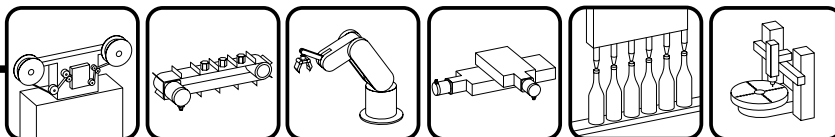

STÖGRA Antriebstechnik GmbH

Machtlfinger Straße 24

D-81379 München

Tel: +49 89 15 90 40 00

Fax: +49 89 15 90 40 09

E-Mail: info@stoegra.de

Internet: <http://www.stoegra.de>

All rights reserved

Without written approval we don't allow reprint or partial copying.

We reserve the right to make engineering changes, refinements and improvements to all products described herein.

Mechanical and electrical ratings and dimensions are, therefore, subject to change without notice.

No liability whatsoever is accepted.

	page
ordering key	4
dimensions standard types	5
keyways and woodruffs	6
overview electrical and mechanical specifications	7
max. operating torque series SM 56	8
max. operating torque series SM 87	10
max. operating torque series SM 88	12
max. operating torque series SM 107	14
max. operating torque series SM 168	16
stepping motor phase current characteristics	16
hollow shaft motors series SMH88 / SMH107	17
standard stepping motor connections SM 56 – SM 168	18
table stepping motors – controls / drivers	19
overview: stepping motor with gear, encoder and brake	20
stepping motor series SM 56 with D-Sub connector	20
stepping motor with planetary gear series SM 56 PE	21
stepping motor with planetary gear series SM 87 PE / SM 88 PE	22
stepping motor with planetary gear series SM 107 PE	23
stepping motor with integrated encoder E50	24
stepping motor with integrated encoder H200 and H500	25
stepping motor with brake	26
dimensions stepping motor with gear, encoder and brake	27
cable glands	27

4 ordering Key

STÖGRA Stepper motors are designed as modular system. This enables us to provide a great variety of standard motor types and a high flexibility for customer specific solutions.

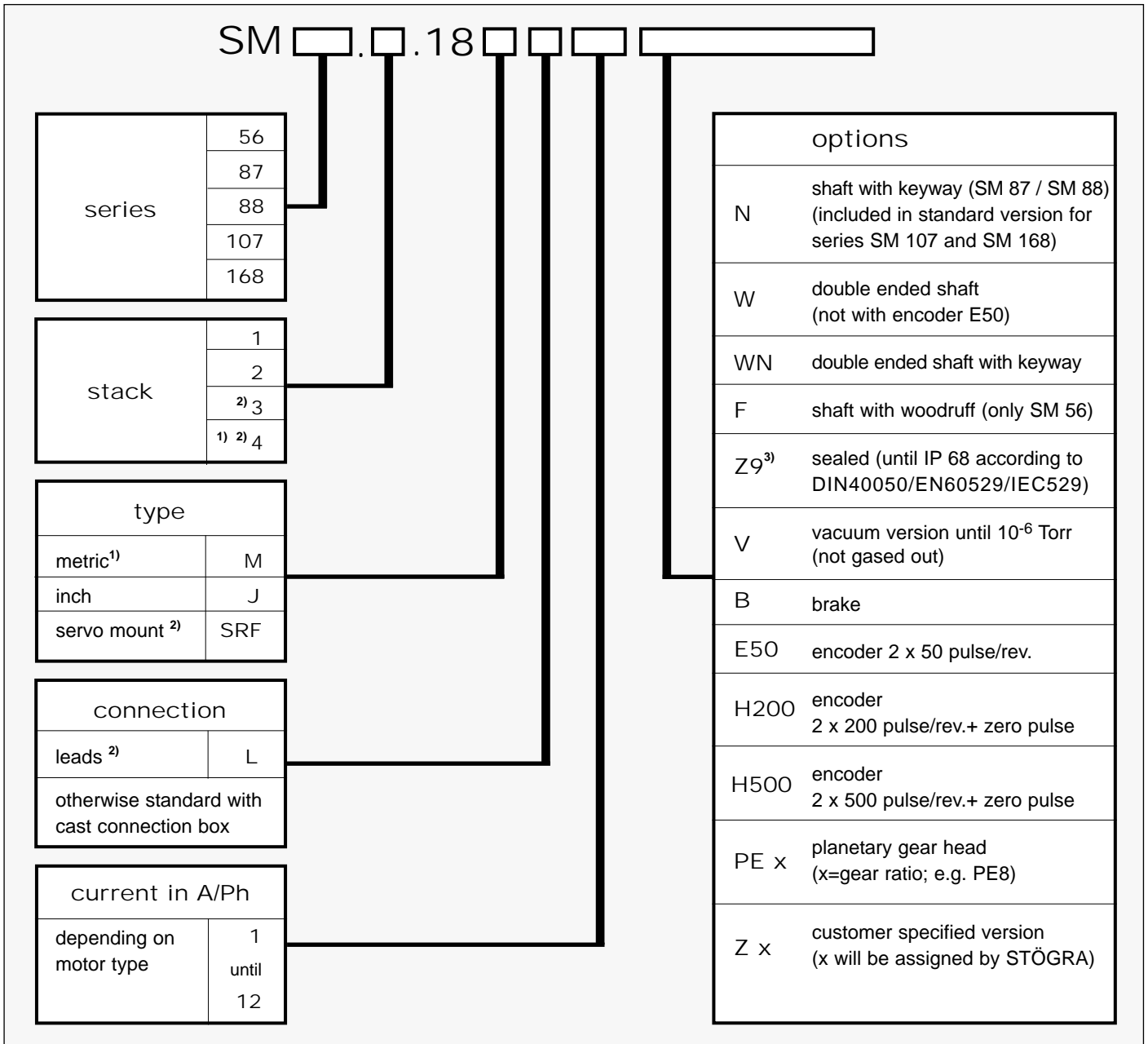

¹⁾ not for series 56 ²⁾ not for series 168

³⁾ IP68 according to DIN 40050 / EN60529 / IEC529 – IP58 according to VDE0530-5 / EN60034-5 / IEC34-5

Please note, not all options can be combined!

Series SM 86, SM 108 and SM 109 still are available for spare parts, but they should not be used for new designs.

Cable glands are not included in standard motor deliveries! Cable glands must be ordered additionally.

general STÖGRA motor specifications:

- ± 3% accuracy based on 1.8° motor step angle (non cumulative)
- operating temperature -30°C until 80°C (short time until 100°C) for standard types
- insulation class F according to VDE 0530
- dielectric motor strength 1800 vrms (series 56: 1000 vrms)
- high bearing thrust and overhang loads

order examples:

SM 56.2.18 J3 E50 PE8
SM 87.1.18 ML3
SM 88.3.18 M8 BH200
SM 107.2.18 M12 BE50 PE4
SM 168.2.18 M12

5 dimension

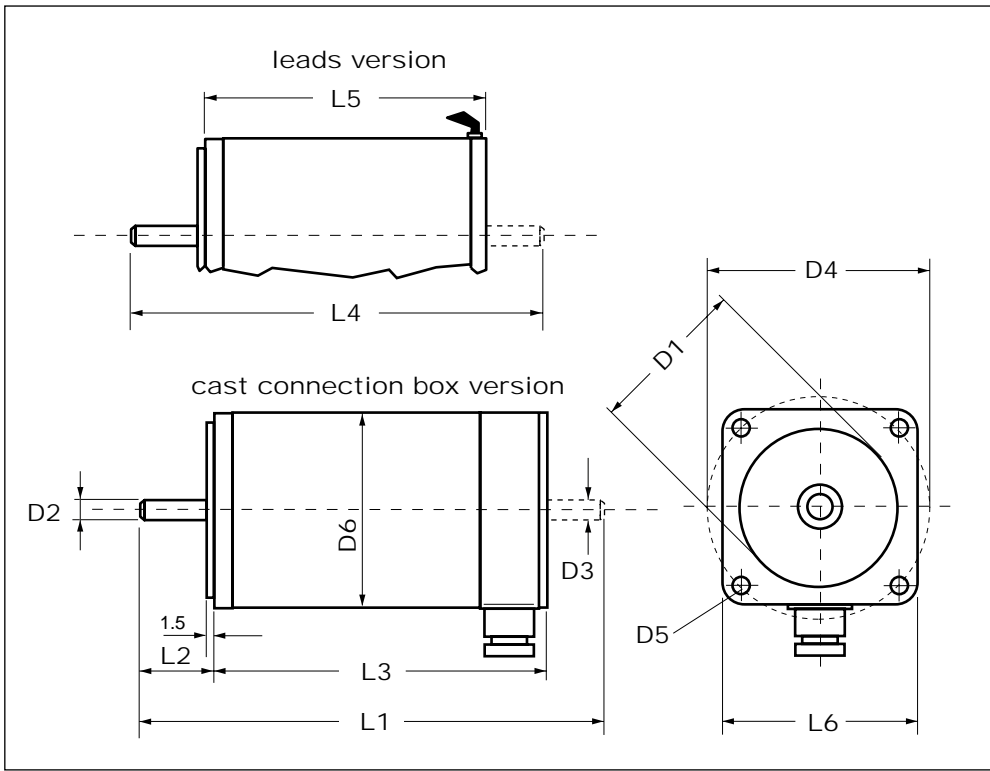

stepping motor		D1 -0.05		D2 -0.02		D3 -0.02		D4		D5	D6	L1	L2	L3	L4	L5	L6	thread of cable entry
series	type	M	J	M	J	M	J	M	J				+0.5	±0.5		±0.5		
56	SM 56.1.18											108		76	90	50		M20 x 1.5
	SM 56.2.18		38.1		6.35		6.35		66.5	5.3	56.5	134	21	102	116	76	56.5	
	SM 56.3.18											162		130	144	104		
87	SM 87.1.18											137		85.5	137	60.5		M20 x 1.5
	SM 87.2.18		73	10	9.52	10	9.52		99	6.5	86	169	31.5	117.5	169	92.5	86	
	SM 87.3.18			(12) ¹⁾		(12) ¹⁾						201		149.5	201	124.5		
	SM 87.4.18											233		181.5	233	156.5		
88	SM 88.1.18											145		93.5	145	68.5		M20 x 1.5
	SM 88.2.18		73	12	9.52	12	9.52		99	6.5	86	177	31.5	125.5	177	100.5	86	
	SM 88.3.18			(10) ¹⁾		(10) ¹⁾						209		158.5	209	132.5		
	SM 88.4.18											241		189.5	241	164.5		
107	SM 107.1.18			12	12.7	10						170	32	111		89.5		M20 x 1.5
	SM 107.2.18		60	55.54			12.7	127.5	125.5	8.5	108	238		161		139.5	108	
	SM 107.3.18				16	15.87	12					288	50	211		189.5		
	SM 107.4.18											338		261		239.5		
168	SM 168.1.18		180		24	19		215		15	168	268	50.5	179			192	PG16
	SM 168.2.18											343		254				

¹⁾ series SM87 also available with 12 mm shaft and series SM88 also available with 10 mm shaft

all dimensions in mm

M = metric

J = inch

6 keyways and woodruffs

keyways:

Series SM107 and SM168 are delivered in standard version with keyway (but not on double ended shaft).

At series SM87 the keyway is an option, which has to be indicated at the ordering key.

keyway DIN 6885 T1		stepping motor			keyway DIN 6885 T1		
series	type	M	J	SRF	type A b x h x l	a	¹⁾ a
56	SM 56.1.18	/	0	0	A2 x 2 x 12	3	3
	SM 56.2.18						
	SM 56.3.18						
87	SM 87.1.18	0	0	0	bis Ø10 A3 x 3 x 15 ab Ø12 A4 x 4 x 15	6	1.5
	SM 87.2.18						
	SM 87.3.18						
	SM 87.4.18						
88	SM 88.1.18	0	0	0	bis Ø10 A3 x 3 x 15 ab Ø12 A4 x 4 x 15	6	1.5
	SM 88.2.18						
	SM 88.3.18						
	SM 88.4.18						
107	SM 107.1.18	S	/	/	A5 x 5 x 20	5	5
	SM 107.2.18						
	SM 107.3.18						
	SM 107.4.18						
168	SM 168.1.18	S	/	/	A8 x 7 x 25	5	5
	SM 168.2.18						

¹⁾double ended shaft

woodruff DIN 6888		stepping motor		woodruff DIN 6885 T1			
series	type	J	SRF	type s x h	d	c	t
56	SM 56.1.18	0	0	2 x 2.6	7	7	1.8
	SM 56.2.18						
	SM 56.3.18						

/ = no standard stepping motor

S = standard – stepping motor is delivered with keyway in standard version

O = option – stepping motor is delivered without keyway or woodruff in standard version

order examples:

SM 56.2.18 J3F with woodruff

SM 87.2.18 M6 N with keyway at front shaft

SM 87.2.18 M6 WN with keyway only at double ended shaft

SM 87.2.18 M6 NWN with keyway at front and double ended shaft

7 overview electrical and mechanical specifications

electrical and mechanical specifications

weight and rotor inertia are for standard versions with cast connection box, without double ended shaft.		electrical specifications				mechanical specifications						
		resistance per phase	inductance per phase	current per phase unipolar	current per phase bipolar	step angle (at full step)	holding torque	detent torque	rotor inertia	bearing thrust load	bearing overhang load	weight
series	motor type	Ohm	mH	A	A	°	Nm	Nm	kgcm ²	N	N	kg
56	SM 56.1.18 J1	4.75	9	1	1.4	1.8	0.45	0.01	0.125	80	150	0.6
	SM 56.1.18 J3	0.72	1	3	4.2							
	SM 56.1.18 J3.9	0.42	0.64	3.9	5.5							
	SM 56.2.18 J1.5	3.9	9	1.5	2.1	1.8	0.85	0.017	0.25	80	150	1
	SM 56.2.18 J2	2.6	5	2	2.8							
	SM 56.2.18 J3	1.2	2.6	3	4.2							
	SM 56.3.18 J1.5	4.3	9	1.5	2.1	1.8	1.25	0.025	0.375	80	150	1.35
	SM 56.3.18 J3	1.46	3	3	4.2							
SM 56.3.18 J4.6	0.72	1.2	4.6	6.5								
87	SM 87.1.18 M1.6	2.9	6	1.6	2.3	1.8	1.8	0.026	0.65	180	280	1.7
	SM 87.1.18 M3	0.72	1.6	3	4.2							
	SM 87.1.18 M5	0.28	0.7	5	7							
	SM 87.2.18 M3.5	0.9	3	3.5	5	1.8	3.6	0.05	1.3	180	280	2.65
	SM 87.2.18 M4.6	0.48	1.5	4.6	6.5							
	SM 87.2.18 M6	0.38	1	6	8.4							
	SM 87.3.18 M3.5	1.1	5	3.5	5	1.8	5.4	0.08	1.95	180	280	3.65
	SM 87.3.18 M6	0.43	1.7	6	8.4							
	SM 87.3.18 M7	0.33	1	7	10							
	SM 87.4.18 M6	0.55	2.3	6	8.4							
SM 87.4.18 M7	0.42	1.8	7	10	1.8	7.2	0.1	2.6	180	280	4.6	
88 ¹⁾	SM 88.1.18 M2	1.88	11.1	(1.4)	2	1.8	3	0.042	1.35	180	280	1.7
	SM 88.1.18 M4	0.5	2.5	(2.8)	4							
	SM 88.1.18 M8	0.13	0.75	(5.7)	8							
	SM 88.2.18 M2	3.61	26	(1.4)	2	1.8	6	0.08	2.7	180	280	2.65
	SM 88.2.18 M4	0.74	5.5	(2.8)	4							
	SM 88.2.18 M8	0.21	1.5	(5.7)	8							
	SM 88.3.18 M4	1.14	10.9	(2.8)	4	1.8	9	0.13	4.05	180	280	3.65
	SM 88.3.18 M8	0.29	2.6	(5.7)	8							
	SM 88.3.18 M12	0.14	1	(8.5)	12							
	SM 88.4.18 M8	0.37	3.55	(5.7)	8	1.8	12	0.16	5.4	180	280	4.6
SM 88.4.18 M12	0.12	1.75	(8.5)	12								
107	SM 107.1.18 M6	0.3	1.6	5	7	1.8	5	0.11	4	400	650	4.3
	SM 107.1.18 M8	0.225	1.2	5.7	8							
	SM 107.1.18 M12	0.1	0.55	8.8	12.5							
	SM 107.2.18 M8	0.38	2.4	5.7	8	1.8	9	0.21	8	400	650	7.2
	SM 107.2.18 M10	0.25	1.6	7.1	10							
	SM 107.2.18 M12	0.175	1.15	8.8	12.5							
	SM 107.3.18 M10	0.38	2.7	7.1	10	1.8	13	0.3	12	400	650	9.8
	SM 107.3.18 M12	0.28	1.9	8.8	12.5							
SM 107.4.18 M12	0.34	2.7	8.8	12.5	18	17	0.4	16	400	650	12.5	
168	SM 168.1.18 M12	0.18	2.5	8.8	12.5	1.8	19	0.3	31.2	660	1000	18
	SM 168.2.18 M12	0.28	5	8.8	12.5	1.8	38	0.6	64.4	660	1000	23

1) SM88 only with bipolar winding

8 max. operating torque series SM 56

All printed torque performance curves are measured with STÖGRA drives.

- measured with 30 VDC
- - - - - measured with 60 VDC
- without boost



SM 168 SM 107 SM 87/88 SM 56

SM 56.1.18 J1

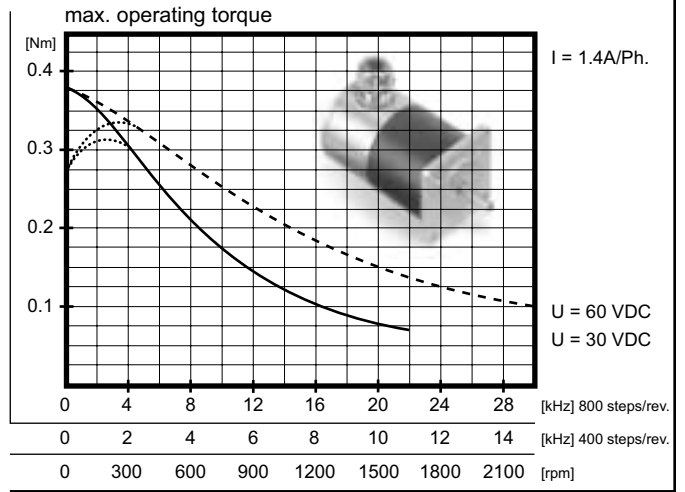

SM 56.2.18 J1.5

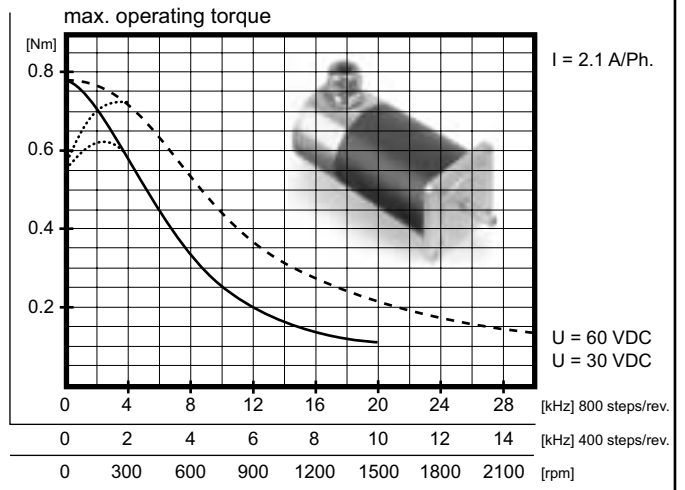

SM 56.3.18 J1.5

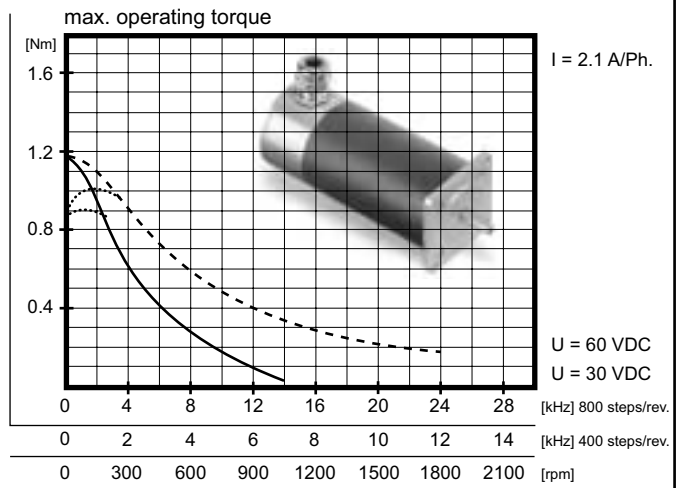

9 max. operating torque series SM 56

SM 56.1.18 J3

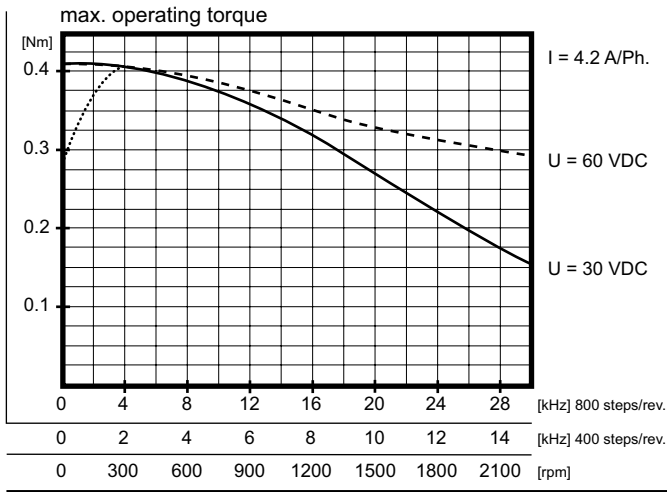

SM 56.1.18 J3.9

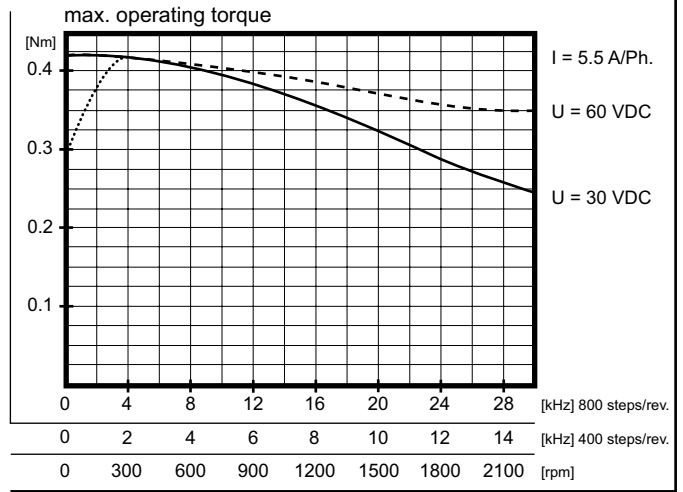

SM 56.2.18 J2

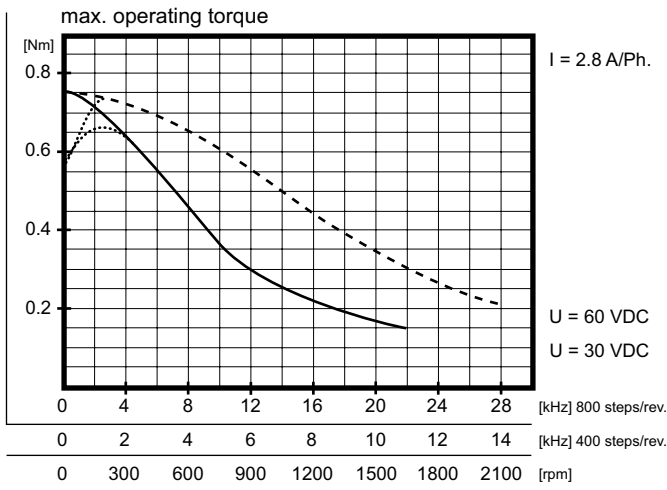

SM 56.2.18 J3

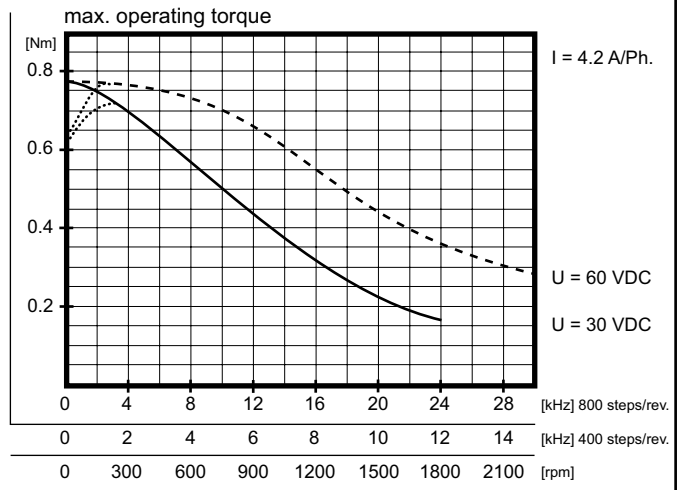

SM 56.3.18 J3

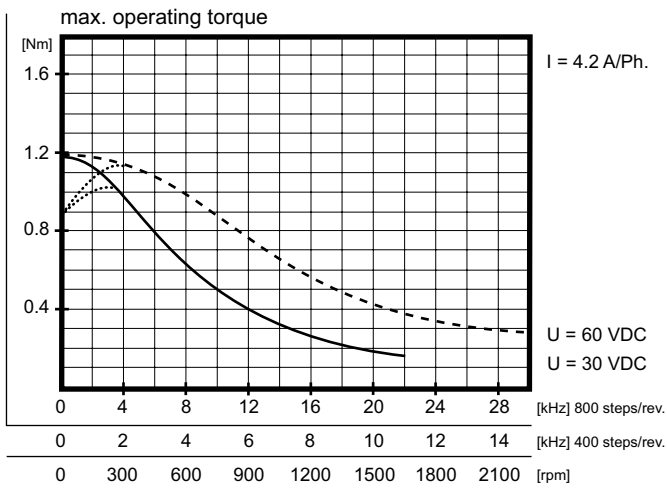

SM 56.3.18 J4.6

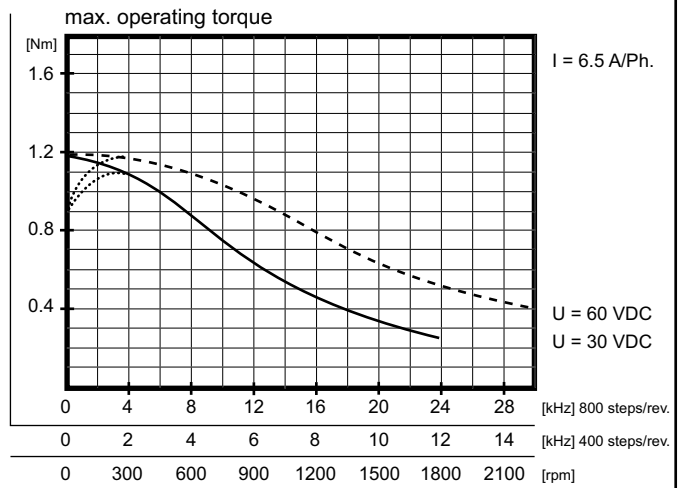

10 max. operating torque series SM 87

All printed torque performance curves are measured with STÖGRA drives.

- measured with 60 VDC
- - - measured with 120 VDC
- ⋯ without boost



SM 168 SM 107 SM 87/88 SM 56

SM 87.1.18 M1.6

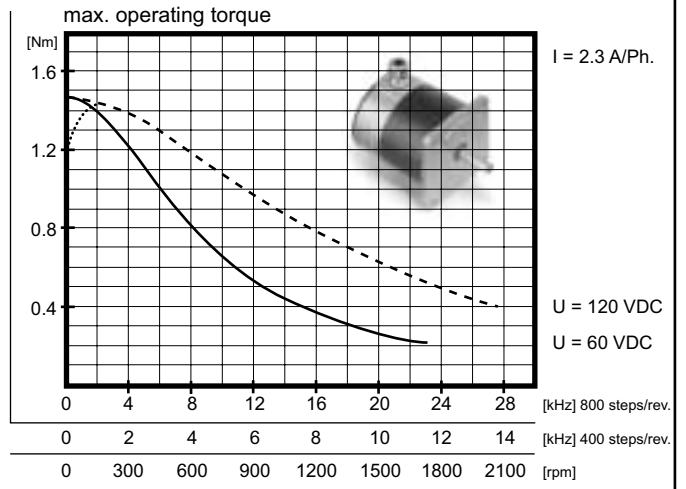

SM 87.2.18 M3.5

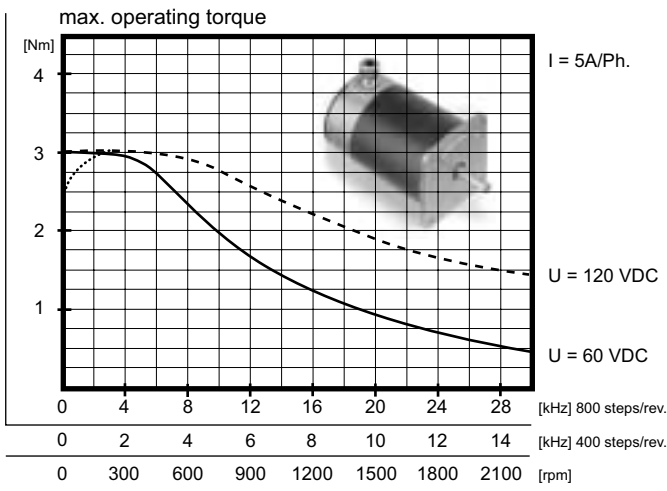

SM 87.2.18 M4.6

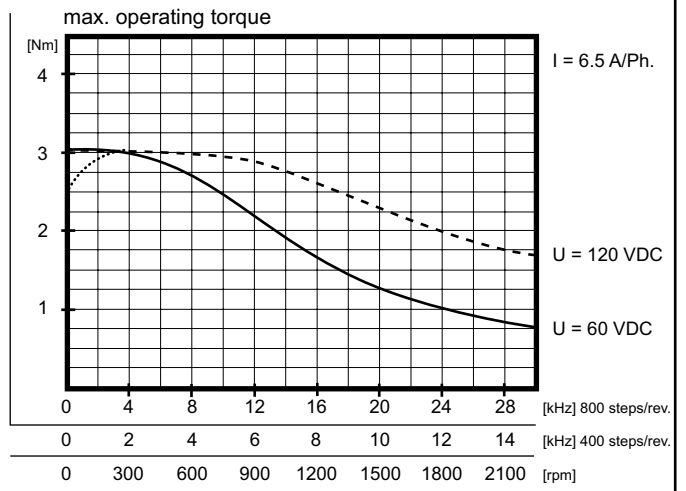

SM 87.3.18 M3.5

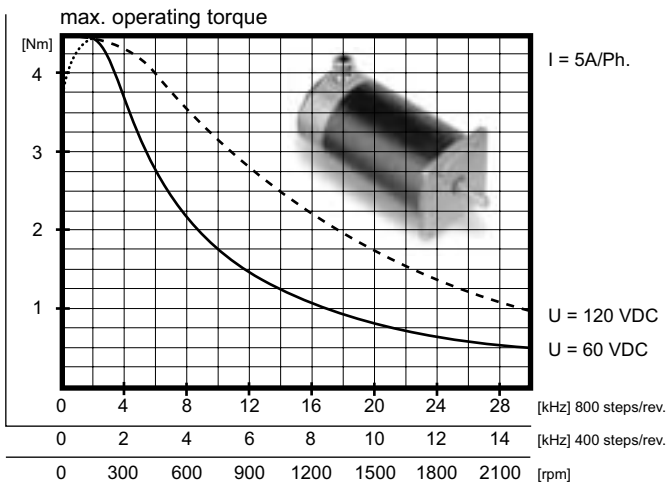

SM 87.3.18 M6

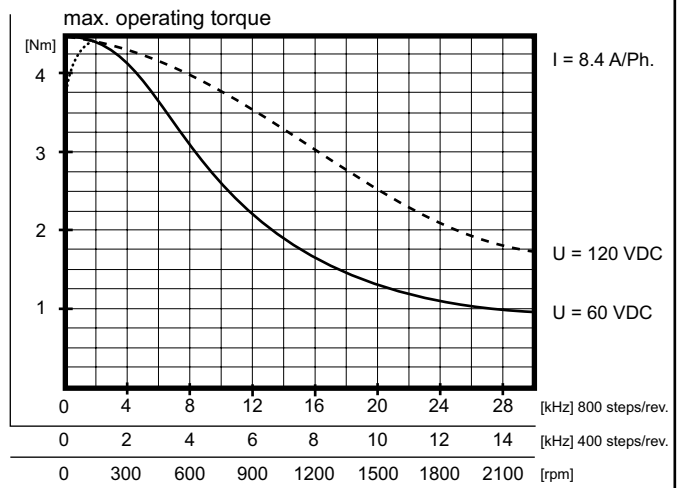

11 max. operating torque series SM 87

SM 87.1.18 M3

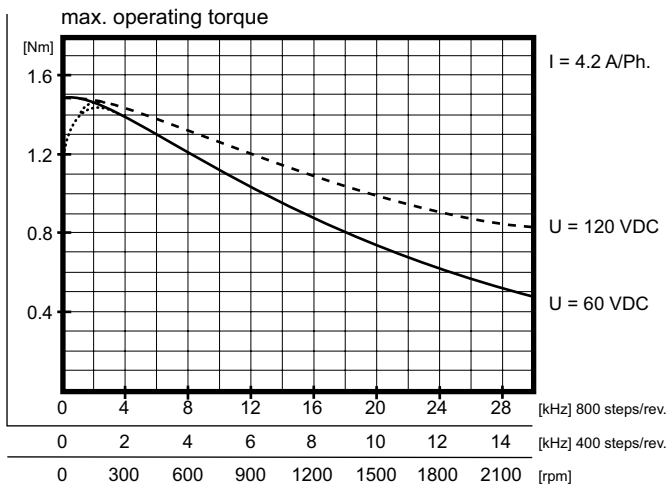

SM 87.1.18 M5

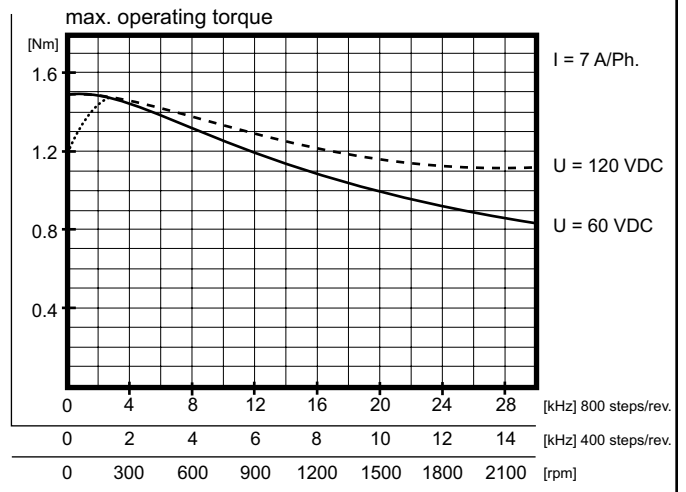

SM 87.2.18 M6

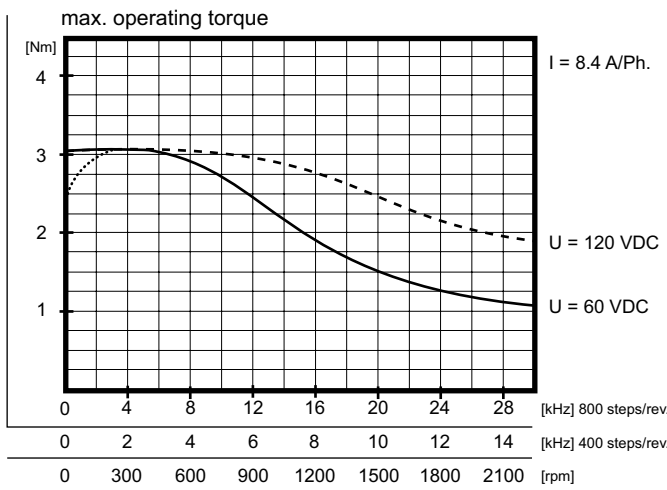

SM 87.4.18 M6

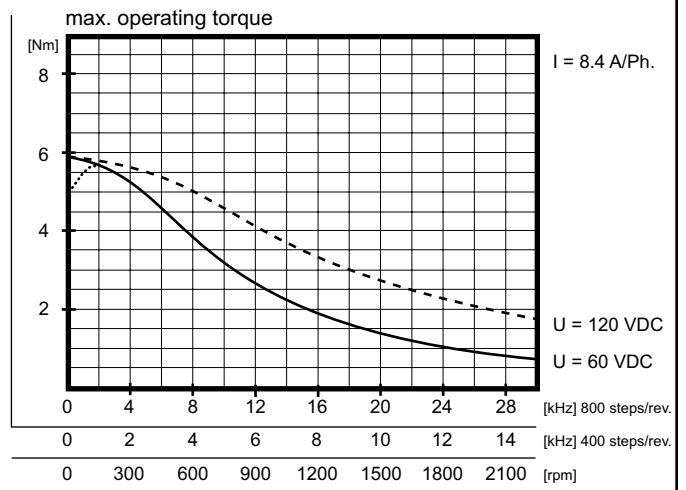

SM 87.3.18 M7

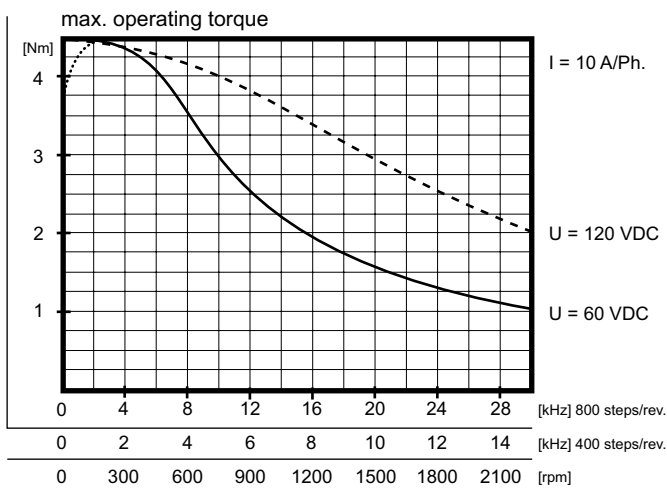

SM 87.4.18 M7

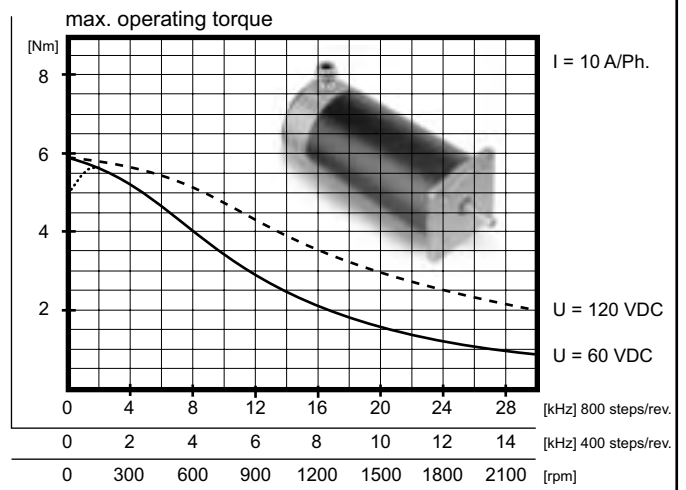

12 max. operating torque series SM 88

All printed torque performance curves are measured with STÖGRA drives.

- rectangular current characteristics
- rectangular current characteristics
- sinus current characteristics



SM 168 SM 107 SM 87/88 SM 56

SM 88.1.18M2

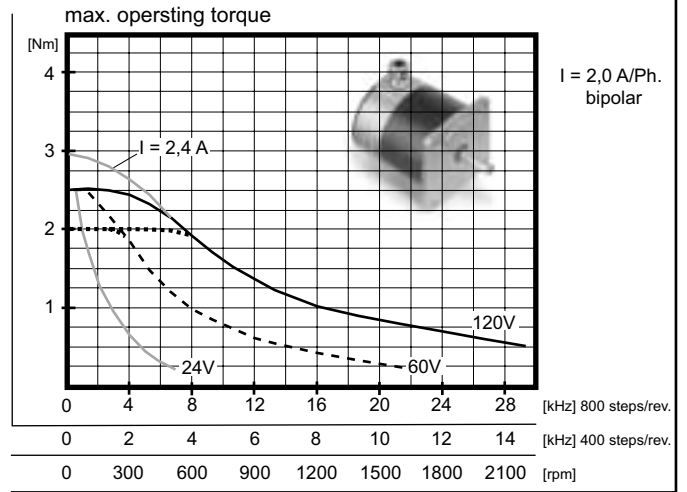

SM 88.2.18M2

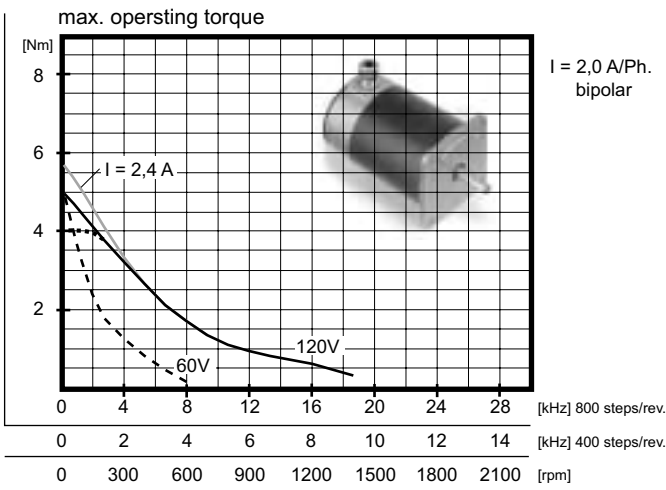

SM 88.2.18M4

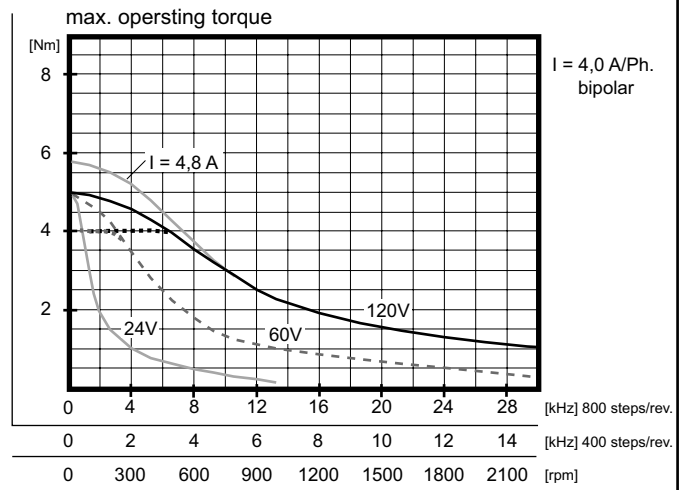

SM 88.3.18M4

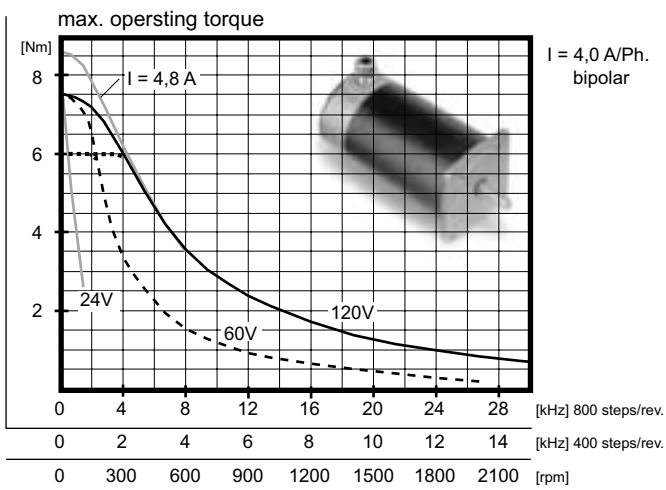

SM 88.3.18M8

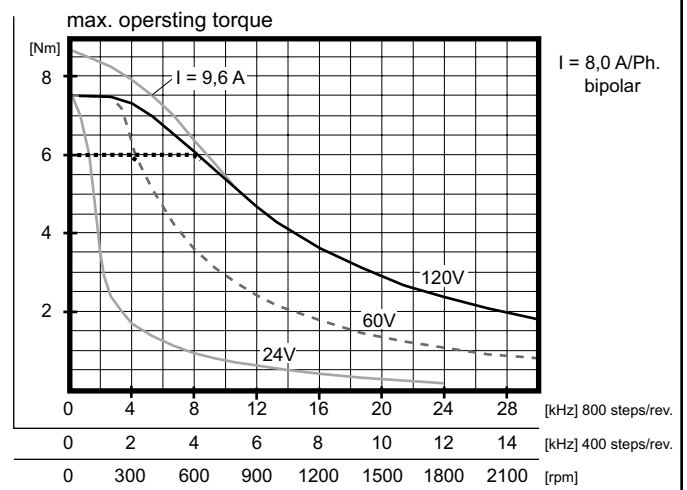

13 max. operating torque series SM 88

SM 88.1.18M4

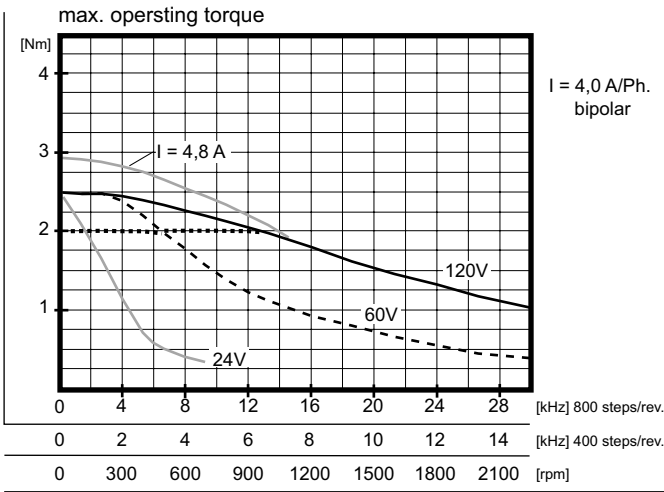

SM 88.1.18M8

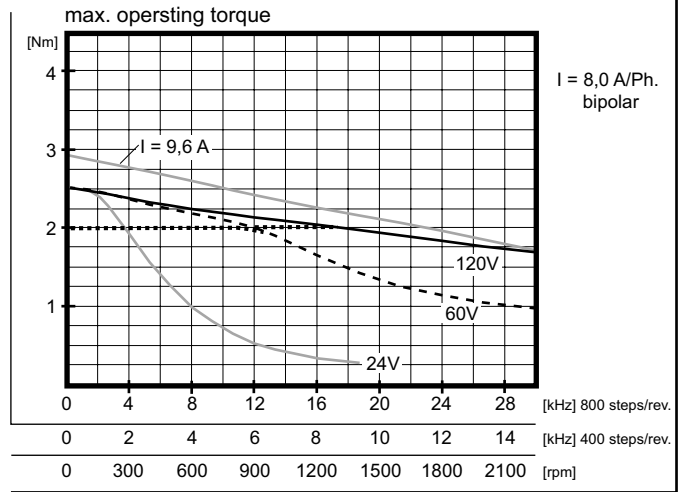

SM 88.2.18M8

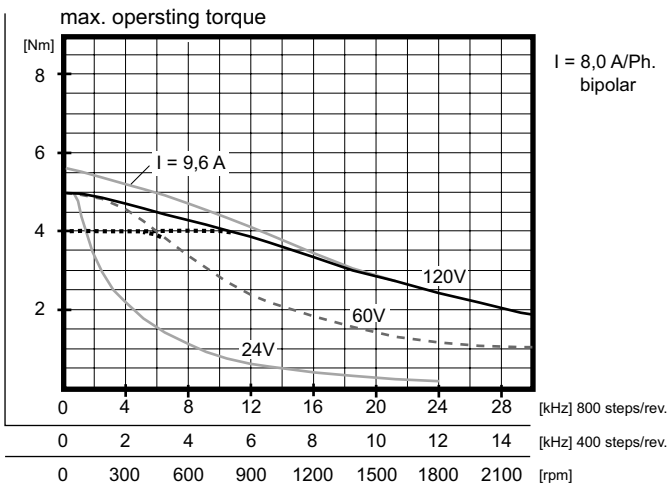

SM 88.4.18M8

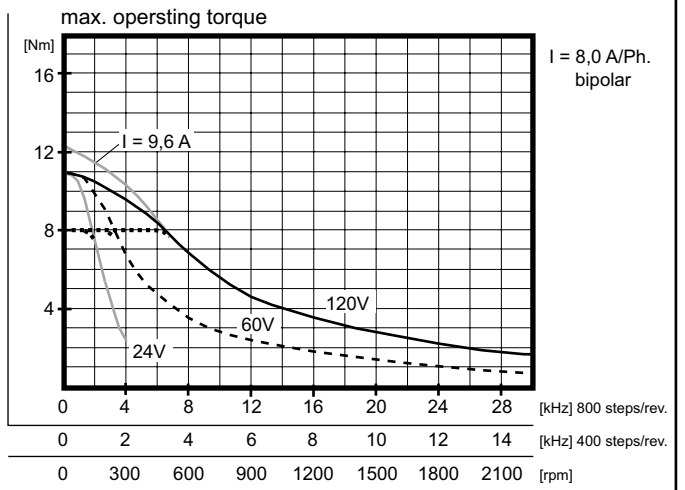

SM 88.3.18M12

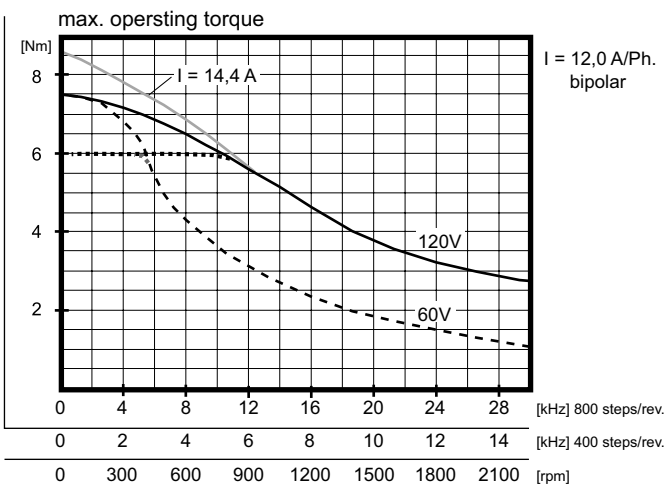

SM 88.4.18M12

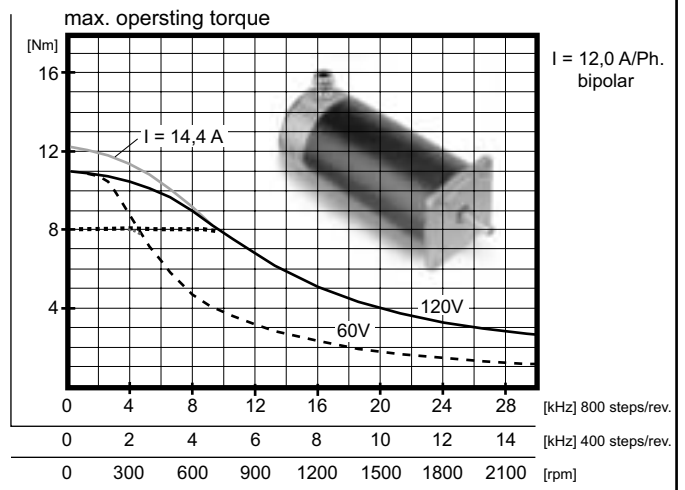

14 max. operating torque series SM 107

SM 107.1.18 M6

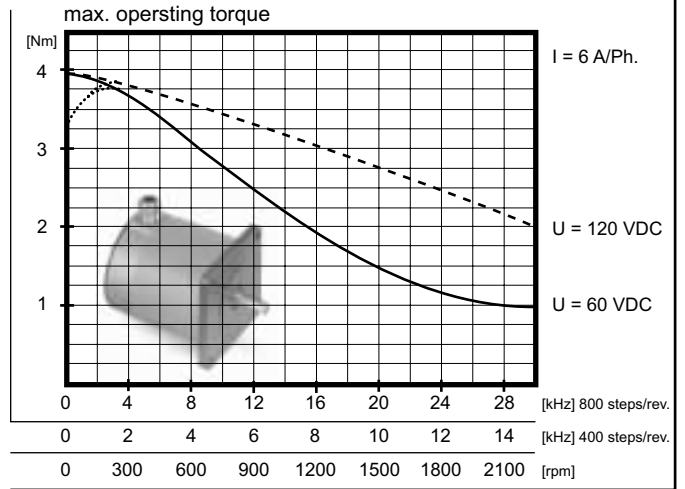

All printed torque performance curves are measured with STÖGRA drives.

- measured with 60 VDC
- - - - - measured with 120 VDC
- without boost



SM 168 SM 107 SM 87/88 SM 56

SM 107.2.18 M8

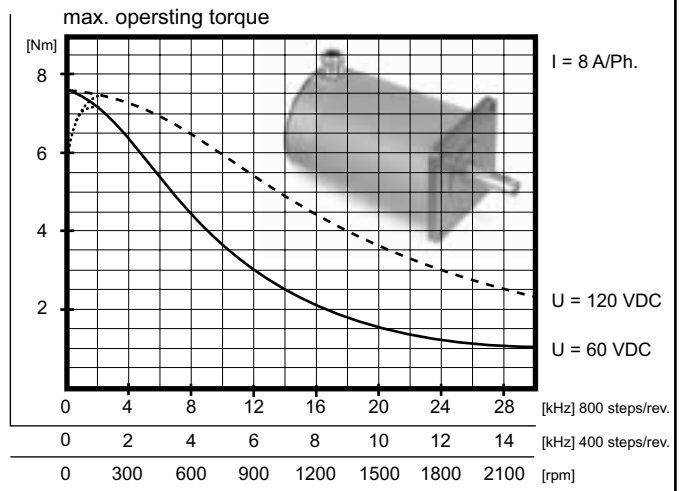

SM 107.3.18 M10

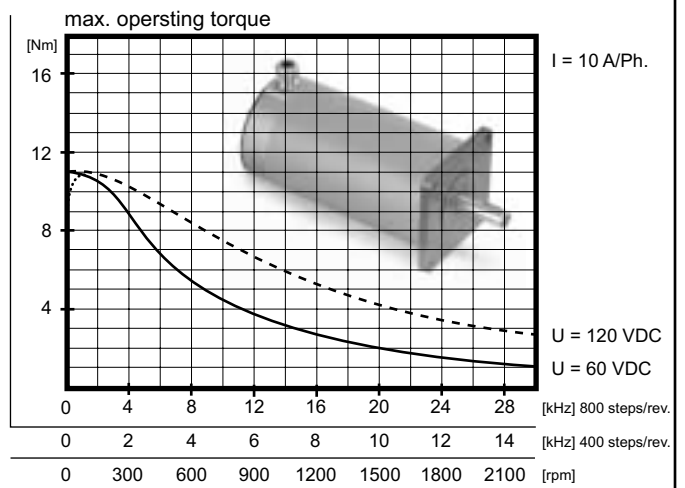

15 max. operating torque series SM 107

SM 107.1.18 M8

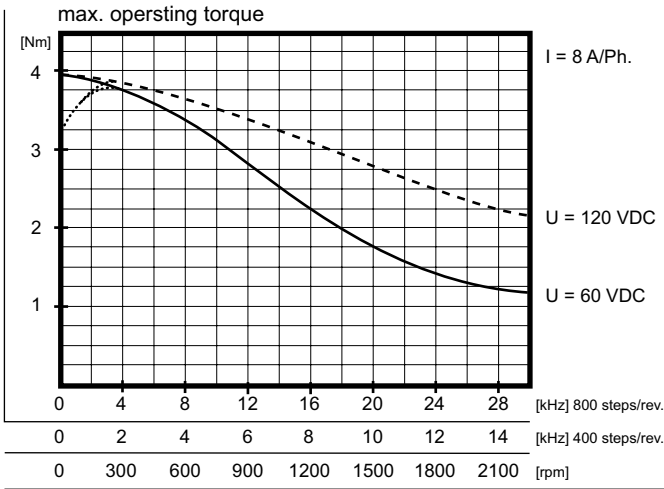

SM 107.1.18 M12

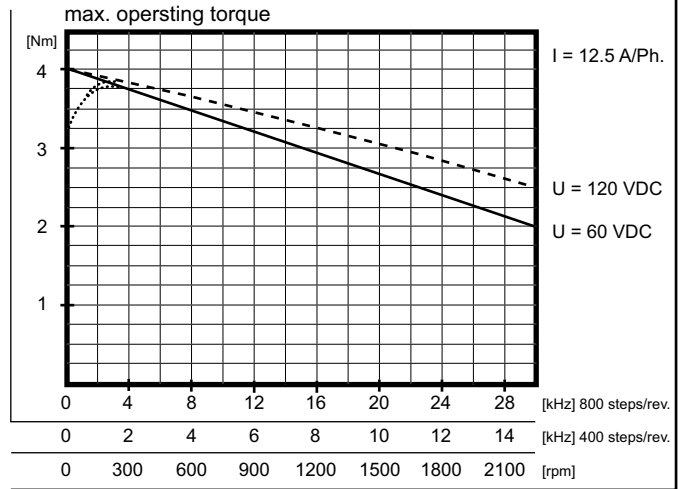

SM 107.2.18 M10

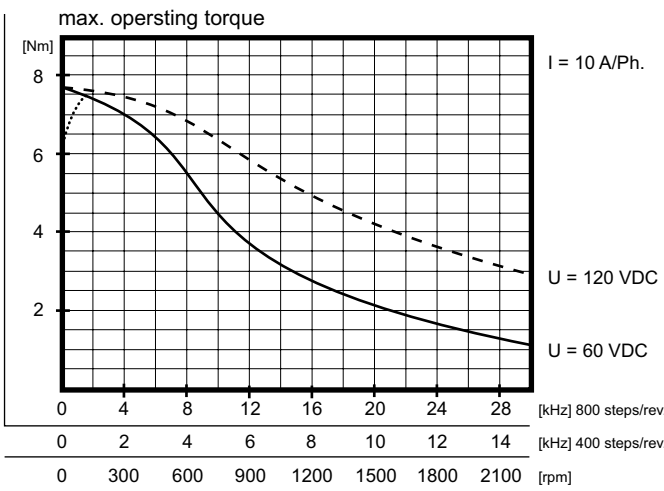

SM 107.2.18 M12

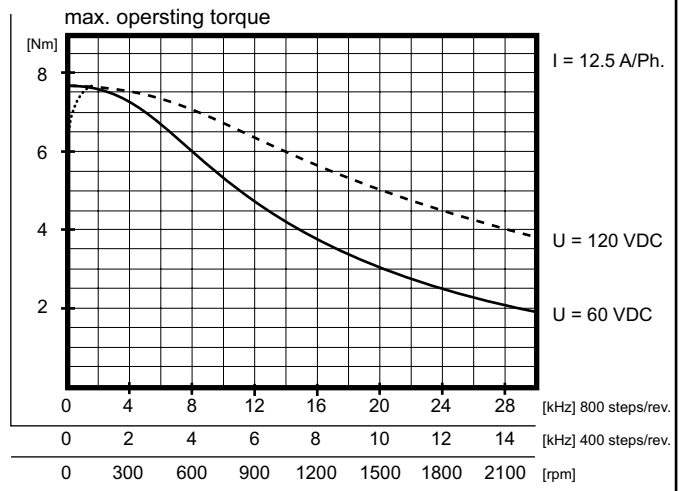

SM 107.3.18 M12

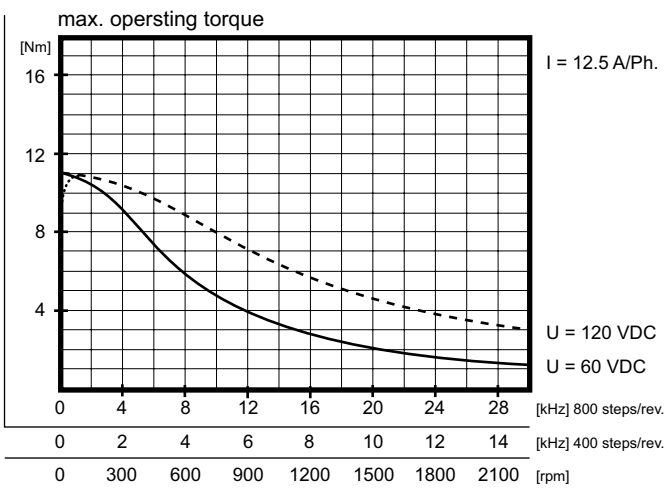

SM 107.4.18 M12

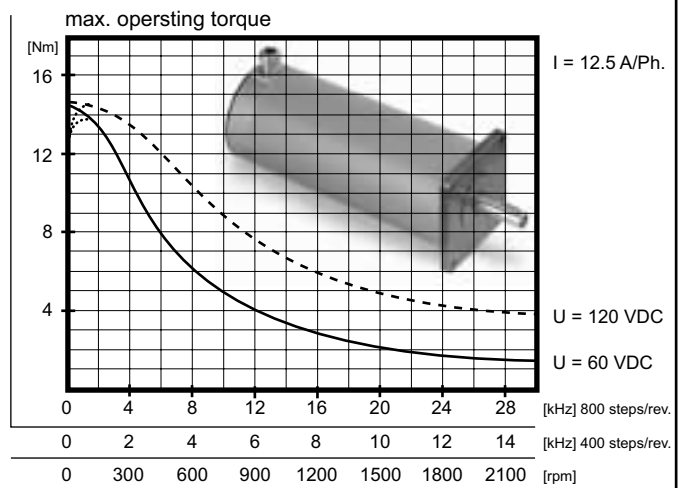

16 max. operating torque series SM 168

All printed torque performance curves are measured with STÖGRA drives.

- measured with 120 VDC
- - - - - measured with 240 VDC
- without boost



SM 168 SM 107 SM 87/88 SM 56

SM 168.1.18M12

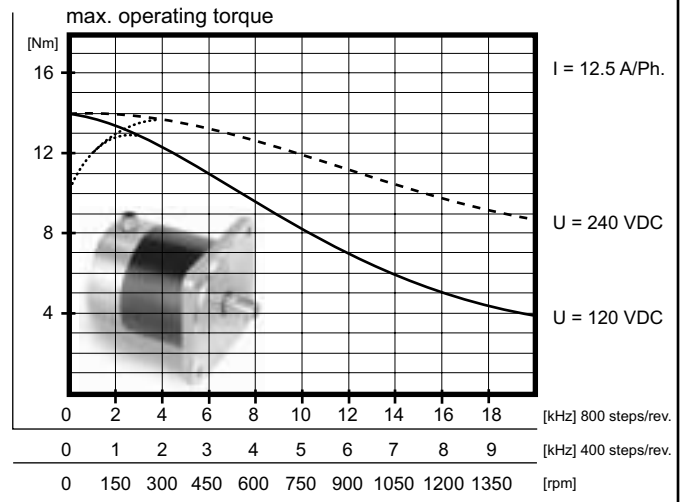

SM 168.2.18M12

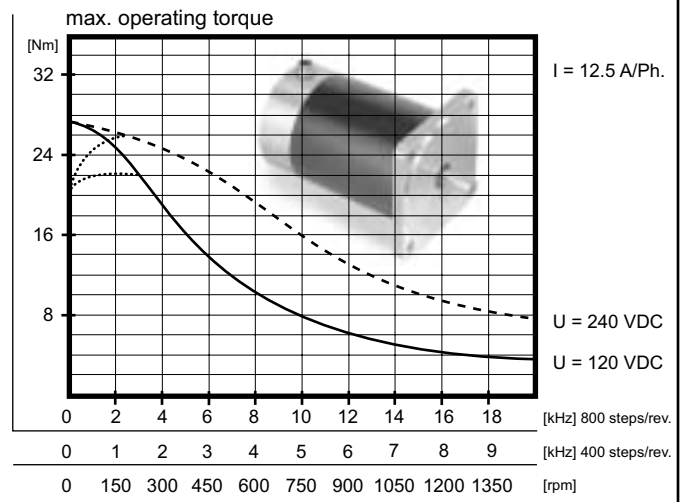

stepping motor phase current characteristics

- - - - - rectangular characteristic - phase current (fullstep / with boost) both phases with nominal current (bipolar)
 - sinus-/cosinus characteristic - phase current (without boost) with peak value = nominal current (bipolar)
- e.g. SM 88.2.18M8
with nominal current 8 A/phase bipolar

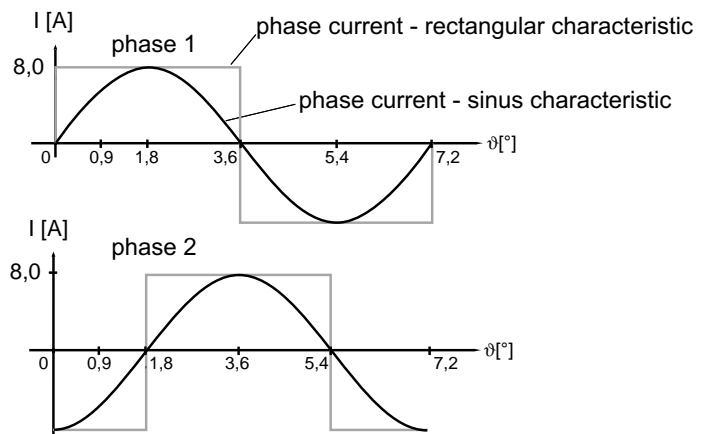

17 series SM hollow shaft

series SMH88

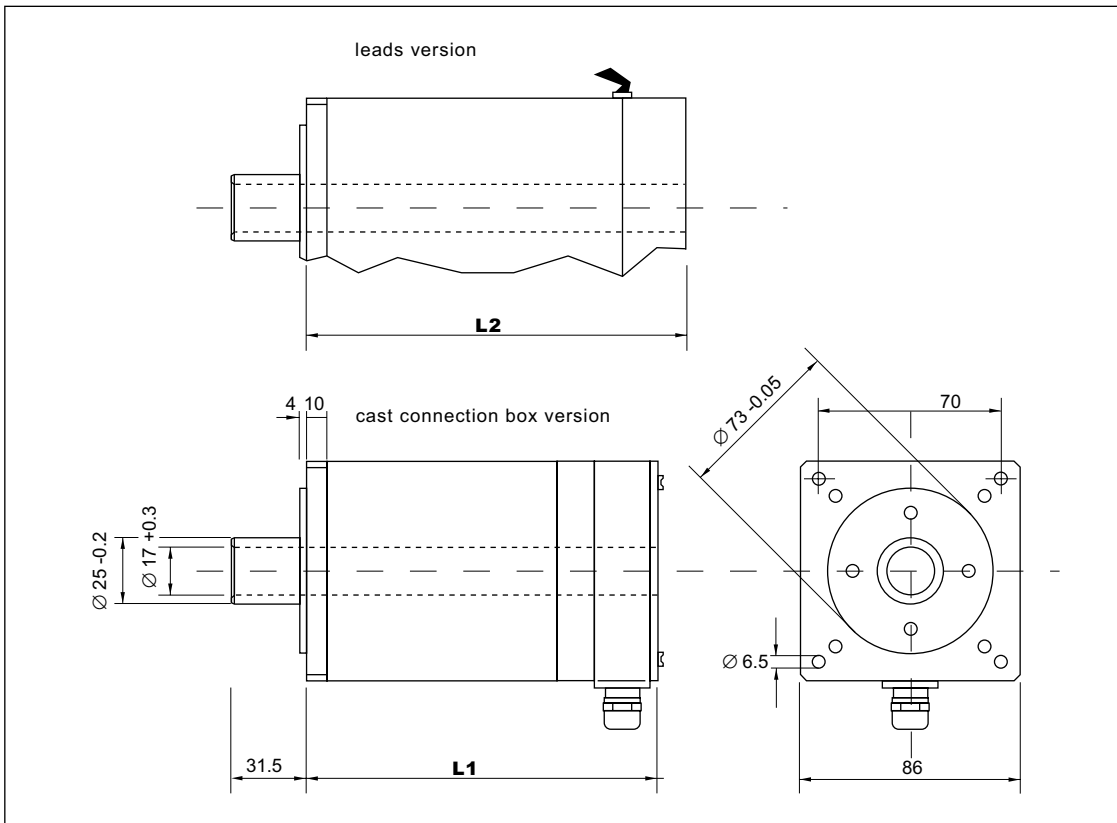

series SMH107

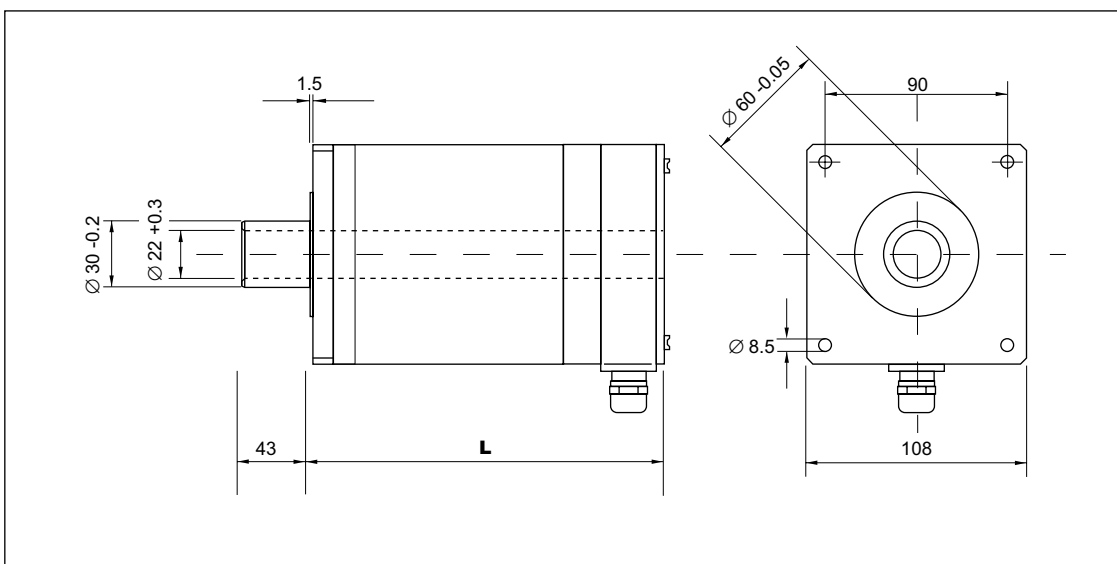

series	type	L1 [mm]	L2 [mm]
SMH88	SMH88.1.M	112.5	87
	SMH88.2.M	144.5	119
	SMH88.3.M	176.5	151
	SMH88.4.M	208.5	183

all dimensions in mm

series	type	L±1
SMH107	SMH107.1.M	140
	SMH107.2.M	190
	SMH107.3.M	240
	SMH107.4.M	290

all dimensions in mm

18 series SM hollow shaft

type key

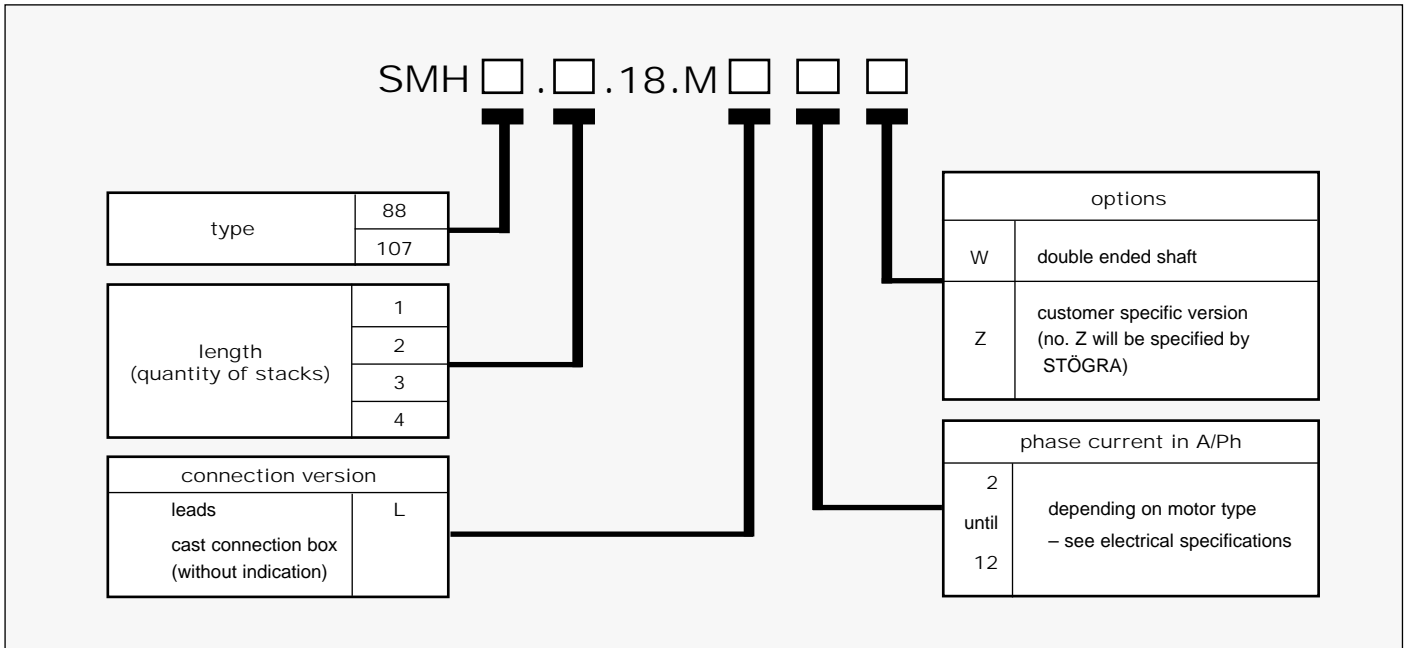

Examples for ordering key:

SMH88.2.18ML4

SMH107.3.18M12

Electrical and mechanical specifications and max. operating torques for series SMH88 are identical to series SM88 (see page 7 and pages 12 – 13) and for series SMH107 the specifications are identical to series SM107 (see pages 7 and pages 14 – 15).

standard stepping motor connections series SM56 – SM168

<p>standard connections: windings bipolar parallel</p>	<p>cast connection box version:</p>	<p>leads version: standard: 9 leads length of leads approx. 300mm</p> <ul style="list-style-type: none"> 1 – brown 2 – white 3 – black 4 – red 5 – blue 6 – grey 7 – yellow 8 – green 9 – green/yellow : PE
<p>windings bipolar serial (not for series SM88)</p>	<p>diagrams are valid only for standard types (e.g. not valid for type SM ... E50)</p>	<p>Series SM 88 only with 5 leads for connection bipolar-parallel: brown, black, blue, yellow and PE</p>

20 overview: stepping motor with gear, encoder and brake

Stepping motor with gear, encoder and brake

STÖGRA-stepping motors are available with various equipment:

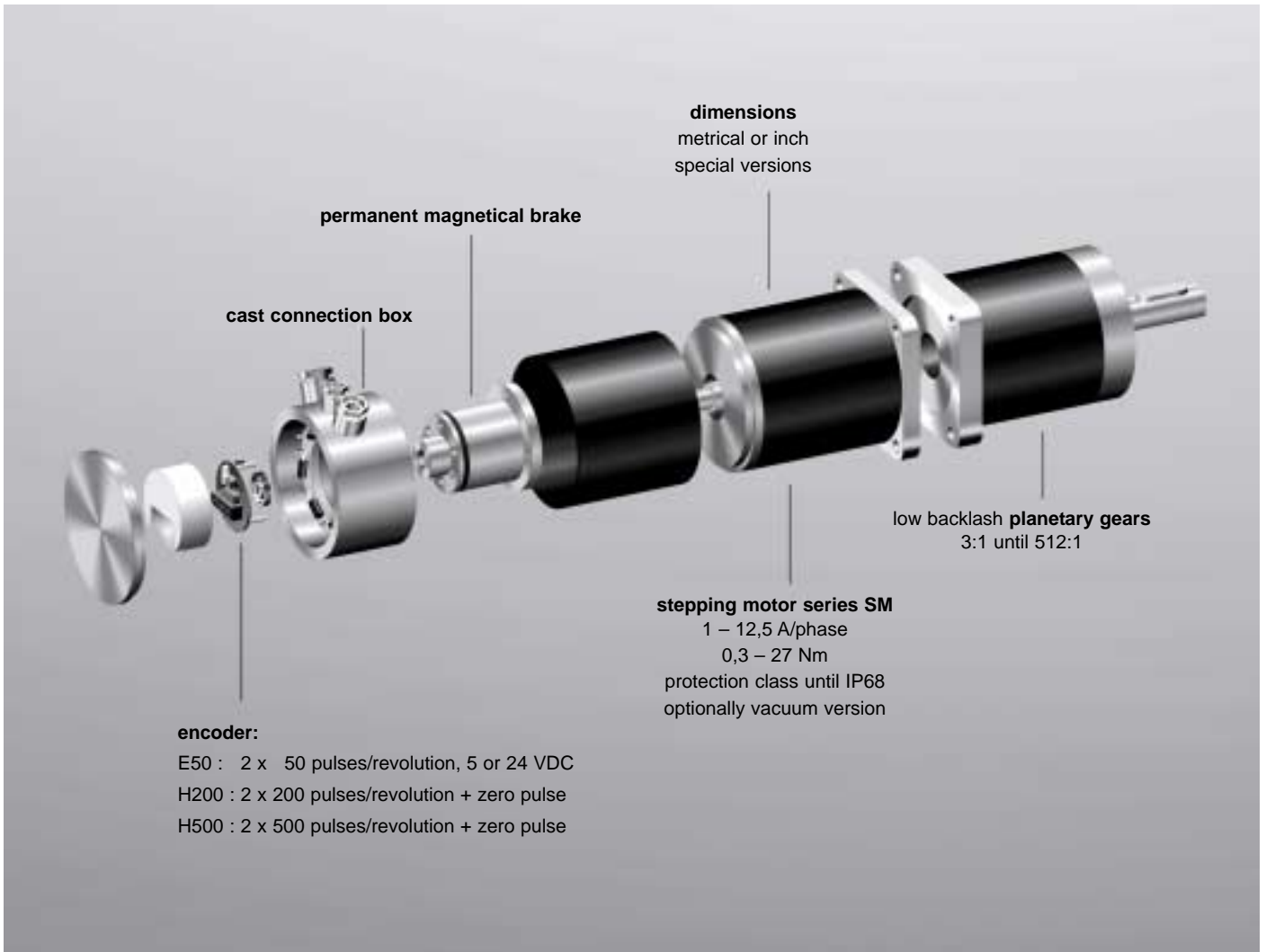

stepping motor series SM 56 with D-Sub connector

For series SM 56 there is a special version with connections for motor, encoder and brake via 9-pole D-Sub male and female connectors.



SM 56... with D-Sub connector



SM 56...E50 with D-Sub connector

21 Stepping motor with planetary gear series SM 56 PE

degree of protection: IP43 torque shaft bearing: ball bearing max. axial load: 600 N based on the center of the output shaft max. radial load: 500 N lubrication: life time lubrication operating temperature: -25°C/+80°C mounting position: any	motor type	^{a)} length B ± 1 mm	inertia kgcm ²
	SM 56.1.18	76	0.125
	SM 56.2.18	102	0.25
	SM 56.3.18	130	0.375

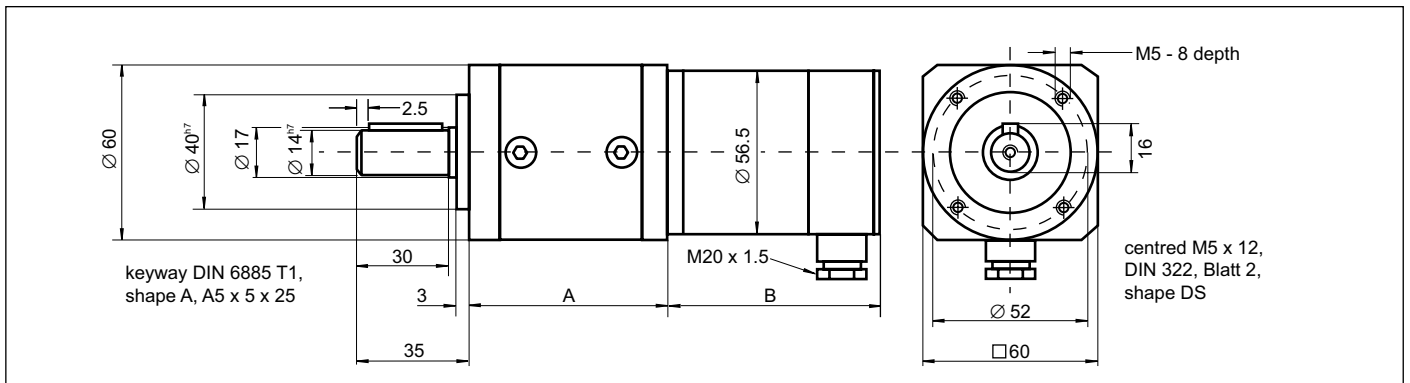

planetary gears series PE											
type	ratio	max. torque output Nm			inertia referred to motor shaft 10 ⁻² kgcm ²	stiffness of distortion Nm/arcmin	absolute backlash angular minutes	efficiency aprox. %	length A mm	weight without motor kg	number of stages
		SM 56.1	SM 56.2	SM 56.3							
PE3	3	1.1	2	3.2	1.5	<20	96	55	0.65	1	
¹⁾ PE4	4	1.5	2.7	4.3							
PE5	5	1.9	3.8	5.4							
¹⁾ PE8	8	3.1	5.4	8.6							
PE9	9	3.3	5.7	9.2	1.5	<25	94	67	0.82	2	
PE12	12	4.4	7.7	12.2							
PE15	15	5.5	9.6	15.3							
PE16	16	5.7	10.2	16.3							
PE20	20	7.3	12.8	20.4							
PE25	25	9.1	15.9	25.5							
PE32	32	11.7	20.4	32.6							
¹⁾ PE40	40	14.6	25.5	40							
PE60	60	20.6	36	44	1.3	<30	90	80	1	3	
PE80	80	27.5	44	44							
PE100	100	34.4	44	44							
PE120	120	41.3	44	44							
PE160	160	44	44	44							
PE200	200	40	40	40							
PE256	256	44	44	44							
PE320	320	40	40	40							
PE512	512	18	18	18							

¹⁾ preferential versions (on stock)

ordering indication: (example) SM 56.2.18J3 PE8

²⁾ standard motor with cast connection box

22 Stepping motor with planetary gear series SM 87 PE / SM 88 PE

degree of protection: IP43 torque shaft bearing: ball bearing max. axial load: 1200 N based on the center of the output shaft max. radial load: 950 N lubrication: life time lubrication operating temperature: -25°C/+80°C mounting position: any	motor type	²⁾ length B ± 1 mm	inertia kgcm ²
	SM 87.1.18	85.5	0.65
	SM 87.2.18	117.5	1.3
	SM 87.3.18	149.5	1.95
	SM 87.4.18	181.5	2.6
	SM 88.1.18	93.5	1.35
	SM 88.2.18	125.5	2.7
	SM 88.3.18	158.5	4.05
	SM 88.4.18	189.5	5.4

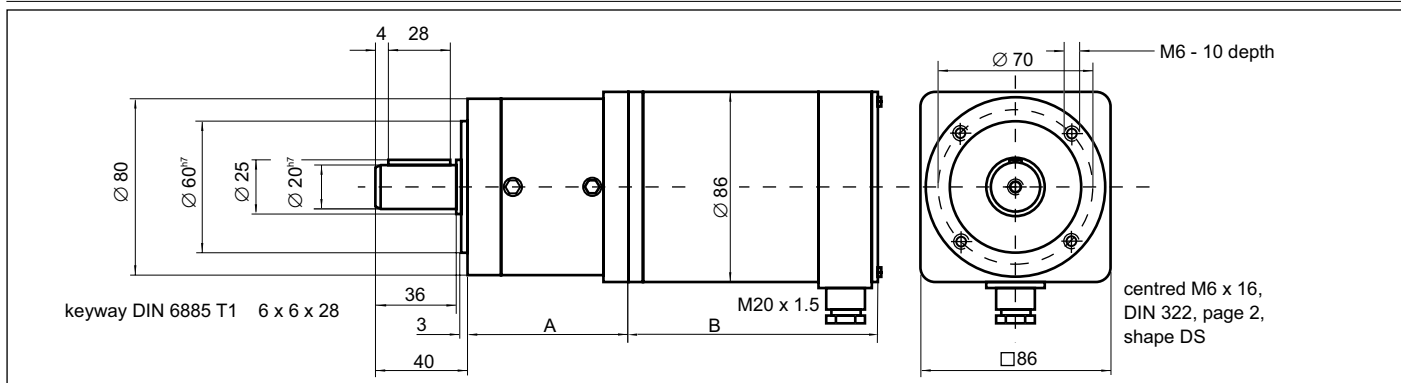

planetary gear series PE																
type	ratio	max. torque output Nm								inertia referred to motor shaft 10 ⁻² kgcm ²	stiffness of distortion Nm/arcmin.	absolute backlash angular minutes	efficiency ca. %	length A mm	weight ohne Motor kg	number of stages
		SM 87.1		SM 88.1		SM 87.2		SM 88.2								
PE3	3	4.3	7.2	8.6	14.4	12.9	21.6	17.3	28.8	63	4.5	<12	96	72	1.6	1
¹⁾ PE4	4	5.8	9.6	11.5	19.2	17.2	28.8	23	38.4	25						
PE5	5	7.2	12	14.4	24	21.6	36	28.8	48	14						
¹⁾ PE8	8	11.5	19.2	23	38.4	34.5	50	46.1	50	8						
PE9	9	12.7	21.1	25.4	42.3	38	63.4	50.7	84.6	63	5.2	<17	94	89	2.2	2
PE12	12	16.9	28.2	33.8	56.4	50.7	84.6	67.7	112.8	26						
PE15	15	21.2	35.2	42.3	70.5	63.4	105.8	84.6	110	62						
PE16	16	22.6	37.6	45.1	75.2	67.6	112.8	90.2	120	25						
PE20	20	28.2	47	56.4	94	84.6	120	112.8	120	15						
PE25	25	35.3	58.7	70.5	110	105.7	110	110	110	15						
PE32	32	45.1	75.2	90.2	120	120	120	120	120	8						
¹⁾ PE40	40	56.4	94	110	110	110	110	110	110	8						
PE64	64	50	50	50	50	50	50	50	50	6						
PE60	60	81	110	110	110	110	110	110	110	25						
PE80	80	108	120	120	120	120	120	120	120	18	4.8	<22	90	106.5	2.8	3
PE100	100	120	120	120	120	120	120	120	120	15						
PE120	120	110	110	110	110	110	110	110	110	60						
PE160	160	120	120	120	120	120	120	120	120	8						
PE200	200	110	110	110	110	110	110	110	110	8						
PE256	256	120	120	120	120	120	120	120	120	8						
PE320	320	110	110	110	110	110	110	110	110	6						
PE512	512	50	50	50	50	50	50	50	50	6						

¹⁾ preferential versions (on stock)

ordering indication: (example) SM 87.1.18 M3 PE8

²⁾ standard motor with cast connection box

23 Stepping motor with planetary gear series SM 107 PE

degree of protection: IP43 torque shaft bearing: ball bearing max. axial load: 2800 N based on the center max. radial load: 2000 N of the output shaft lubrication: life time lubrication operating temperature: -25°C/+80°C mounting position: any	motor type	²⁾ length B ± 1 mm	inertia kgcm ²
	SM 107.1.18	111	4
	SM 107.2.18	161	8
	SM 107 3.18	211	12
	SM 107 4.18	261	16

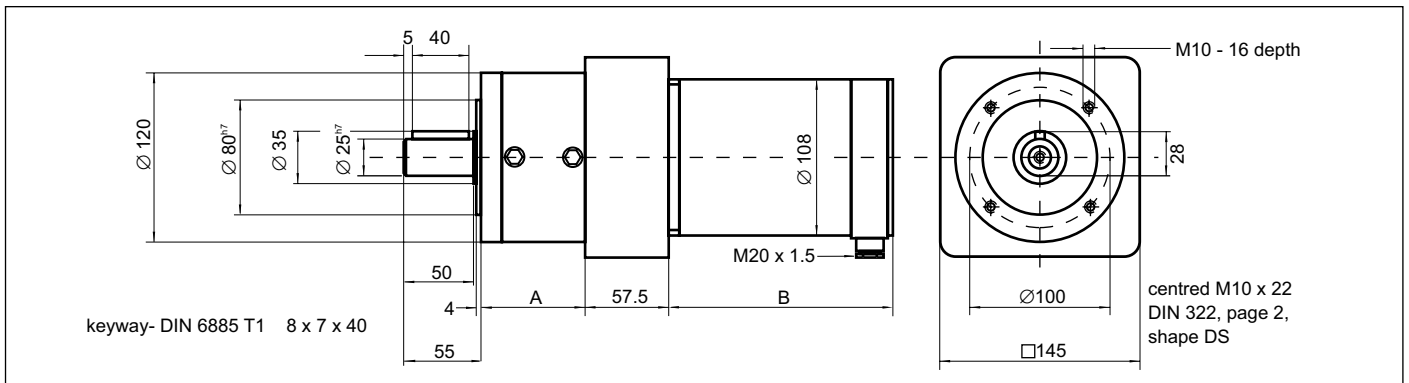

planetary gear series PE												
Typ	ratio	max. torque output Nm				inertia referred to motor shaft kgcm ²	stiffness of distortion Nm/arcmin.	absolute backlash angular minutes	efficiency aprox. %	length A mm	weight without motor kg	number of stages
		SM 1071	SM 1072	SM 1073	SM 1074							
PE3	3	10.8	20.8	29.7	39.4	2.6	11	<8	96	74	6.5	1
¹⁾ PE4	4	14.4	27.7	39.6	52.6							
PE5	5	18	34.7	49.5	65.7							
¹⁾ PE8	8	28.8	55.4	79.2	105							
PE9	9	30.6	58.9	84.2	112	2.62	11	<12	94	101	9	2
PE12	12	40.8	78.5	112	149							
PE15	15	51	98.2	140	186							
PE16	16	54.4	105	150	198							
PE20	20	68	131	187	248							
PE25	25	85	164	230	230							
PE32	32	109	209	260	260							
¹⁾ PE40	40	136	230	230	230							
PE64	64	120	120	120	120	1.3	11	<16	90	128	115	3
PE60	60	192	260	260	260							
PE80	80	256	260	260	260							
PE100	100	260	260	260	260							
PE120	120	230	230	230	230							
PE160	160	260	260	260	260							
PE200	200	230	230	230	230							
PE256	256	260	260	260	260							
PE320	320	230	230	230	230	1.3	11	<16	90	128	115	3
PE512	512	120	120	120	120							

¹⁾ preferential versions (on stock)

²⁾ standard motor with cast connection box

ordering indication: (example) SM 107.2.18 M12 PE8

24 stepping motor - equipment

Stepping motor with integrated encoder

In non disturbed operation the stepping motor runs synchronously to the pulses from the control, that means the motor rotation (= rotation of the rotor) is synchronously to the pulse frequency (= rotating stator field in the motor).

In case of a load at the motor (e.g. via a static load at the motor shaft or because of accelerating the motor – dynamical load) the running of the motor will differ from the pulse frequency within a short time and within a certain max range. This results in changing the load angle (= difference between the real position of the rotor and its position command value).

Stepping motor with integrated encoder E50

The encoder series E50 monitors the movement of the motor. Together with a STÖGRA-drive series SE... E50 or SERS .. E50 the load angle of the stepping motor can be controlled. When exceeding the max. load angle allowed (e.g. in case of the motor running is interrupted because of a mechanical overload) the drive will create an error signal.

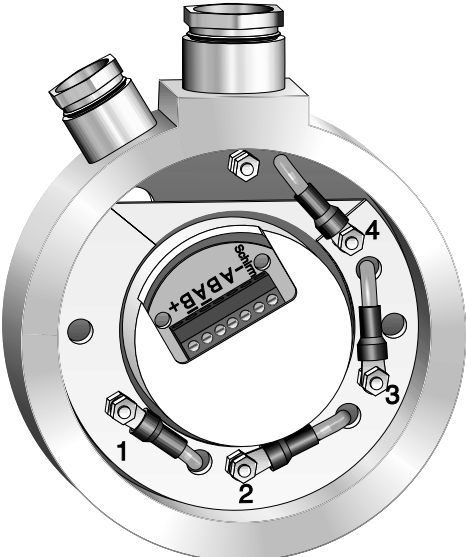
	<p>special characteristics</p> <ul style="list-style-type: none"> • Simple and robust low cost version • No changes of the motor dimensions in comparison to the standard version with cast connection box (except SM 56) • The encoder is integrated in the motor housing. There is no additional measure necessary for protection – available until IP68 • All requirements for mechanical and climatical ambient conditions (vibration-, shake-, shock resistance, temperature and humidity) are fulfilled. • Evaluation of the encoder signals and realisation of a step angle control with generation of an error signal can be done by using standard STÖGRA power amplifier boards series SE ... E50
--	---

Specifications E50

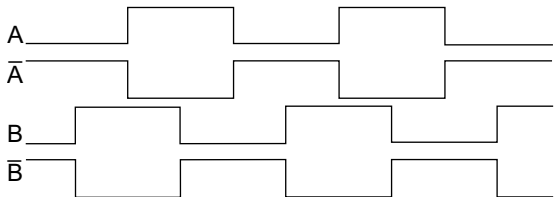
<p>Electrical specifications</p> <ul style="list-style-type: none"> • Voltage supply: 5VDC (optionally 24VDC) • Current consumption: typ. aprox. 35mA (no load at outputs) – max. load at outputs 100mA/output • Operating temperature: max. 100°C 	
<p>Outputs</p> <ul style="list-style-type: none"> • 2 x 50 pulses/revolution – signals A and B with rectangle shape and inverted signals \bar{A} and \bar{B} • Duty cycle 1:1 ± max. 10% error • bipolar – switching to VCC and GND • short circuit protected • pulse frequency min. 20 kHz 	<p>Signal outputs</p> 
<p>Connections</p> <p>Connection via screw terminals for nominal cross section max. 1mm² (26 – 16 AWG) for series SM56 also available as plug connector (see page 20 – figures below)</p> <p>Dimensions as standard motor types! (exept series SM 56 – see table page 27)</p>	

25 stepping motor – equipment

Stepping motor with integrated encoder H200 and H500

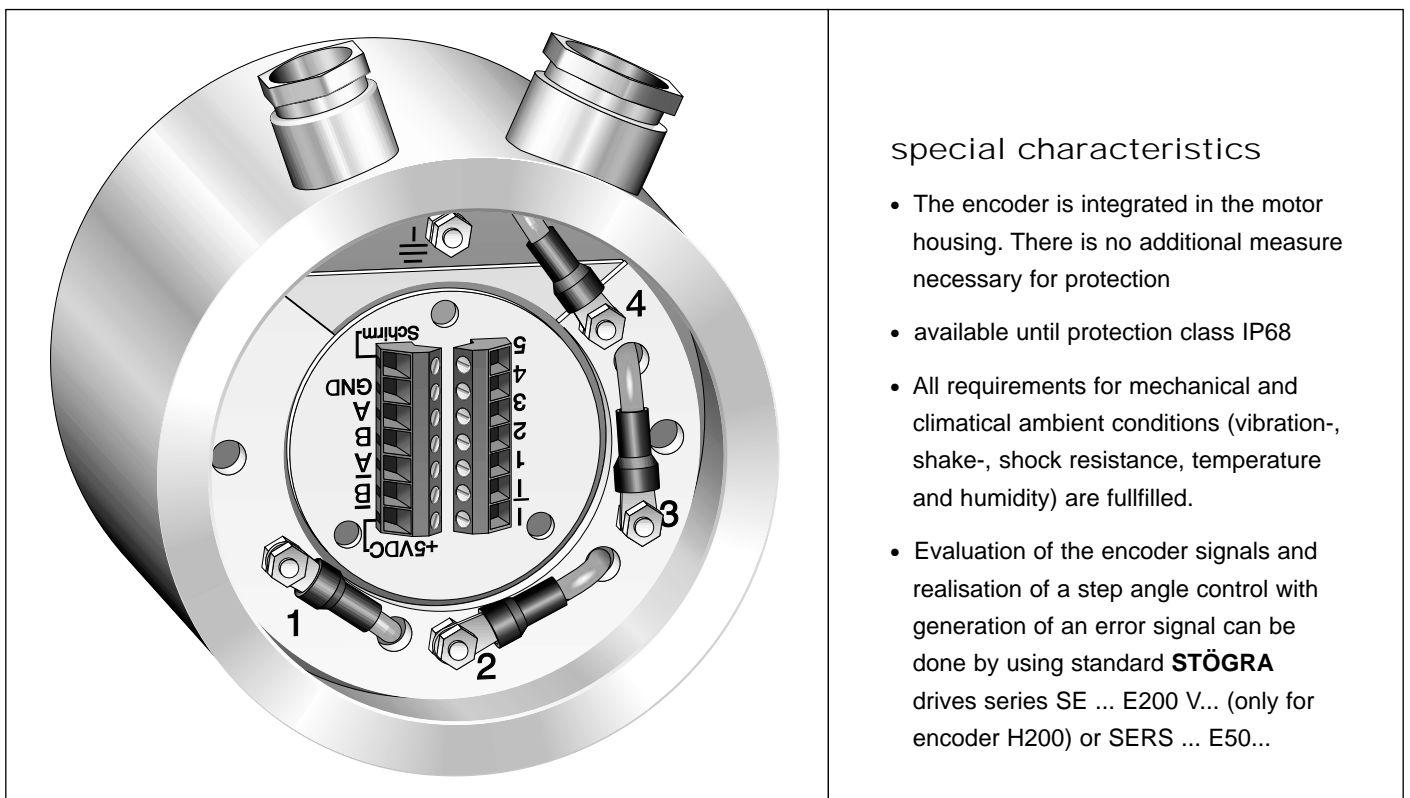

Technical specifications H200 and H500

<p>General specifications H200 and H500</p> <ul style="list-style-type: none"> • Optical encoder • Voltage supply: 5 VDC • Operating temperature: max. 100°C 	
<p>Outputs</p> <ul style="list-style-type: none"> • 2 x 200 pulses/rev. for H200 2 x 500 pulses/rev. for H500 rectangle shape signals A and B, and inverted signals \bar{A} and \bar{B} • H200 and H500: zero pulse and inverted zero pulse - 1 pulse/rev. • Duty cycle 1:1 \pm max. 10% error • RS422 – line driver • short circuit protected • Pulse frequency min. 100 kHz 	<p>Signal outputs</p>
<p>Dimensions</p> <p>The modified dimensions – in comparison to the standard motors without encoder – can be found in the table at page 27.</p>	
<p>Connections</p> <p>Connection via screw terminals for nominal cross section max. 1mm² (26 – 16 AWG)</p>	

26 stepping motor – equipment

Stepping motor with holding brake

brake type: **permanent magnetical brake**
 current supply: **24V (+3.6V)**
 protection: **as motor protection - until IP 68**
the brake is integrated in the motor housing

Holding brakes are used as emergency brakes in vertical axis (Z-axis) If the motor current is switched off or in case of a power line fault the motor shaft will be retarded.

The brake must be supplied by 24VDC to release the motor shaft.

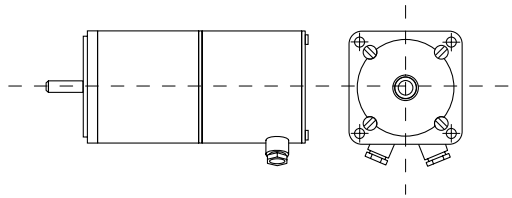

The dimensions of the different motor types with brake can be found in the table of page 27.

Stepping motor with holding brake				brake				
series	type	weight kg	rotor inertia		holding torque Nm	switching time		electr. power / consumption at 24 VDC W / mA
			total kgcm ²	brake kgcm ²		ON ms	OFF ms	
56	SM 56.1.18...B	0.8	0.15	0.02	0.75	7	15	8 / 333
	SM 56.2.18...B	1.2	0.27					
	SM 56.3.18...B	1.6	0.4					
87	SM 87.1.18...B	2.1	0.8	0.15	4	20	15	12 / 500
	SM 87.2.18...B	3	1.45					
	SM 87.3.18...B	4	2.1					
	SM 87.4.18...B	5	2.75					
88	SM 88.1.18...B	2.1	1.5	0.15	4	20	15	12 / 500
	SM 88.2.18...B	3	2.85					
	SM 88.3.18...B	4	4.2					
	SM 88.4.18...B	5	5.55					
107	SM 107.1.18...B	5.2	4.65	0.63	6	35	25	12 / 500
	SM 107.2.18...B	8.1	8.65					
	SM 107.3.18...B	10.7	12.65					
	SM 107.4.18...B	13.4	16.65					

Connections brake

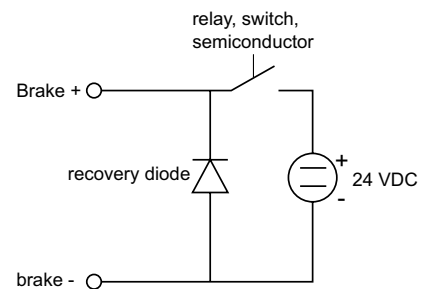
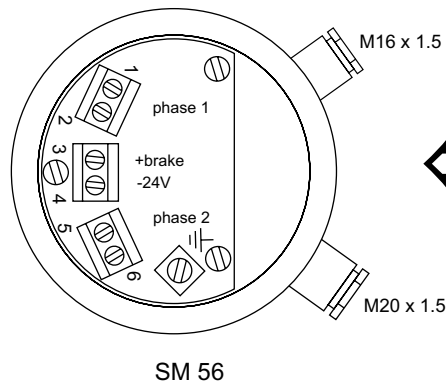
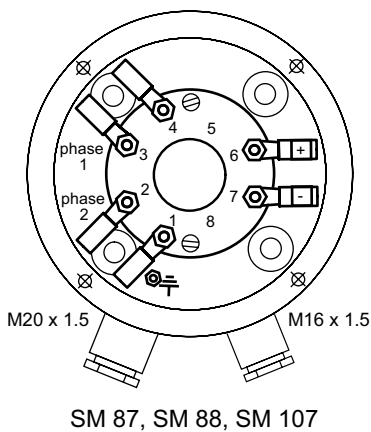

27 stepping motor – equipment

Dimensions stepping motor with gear box, encoder and brake

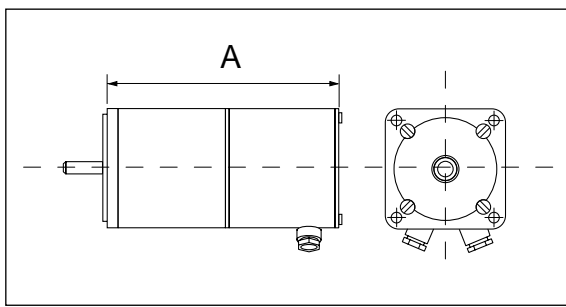

SM 87.2 with brake



SM 87.3 with encoder H200



SM 87.2 with brake and encoder H200

total length A ±0.5 mm	standard with cast connection box	brake	E50	H200/H500	brake and E50	brake and H200/H500
SM 56.1	76	116	88	98	128	137.5
SM 56.2	102	142	114	124	154	163.5
SM 56.3	130	170	142	152	182	191.5
SM 87.1	85.5	131	85.5	104	131	153
SM 87.2	117.5	163	117.5	136	163	185
SM 87.3	149.5	195	149.5	168	195	217
SM 87.4	181.5	227	181.5	200	227	249
SM 88.1	93.5	139	93.5	112	139	161
SM 88.2	125.5	171	125.5	144	171	193
SM 88.3	157.5	203	157.5	176	203	225
SM 88.4	189.5	235	189.5	208	235	257
SM 107.1	111	161	111	136	168.5	193
SM 107.2	161	211	161	186	218.5	243
SM 107.3	211	261	211	236	268.5	293
SM 107.4	261	311	261	286	318.5	343
SM 168.1	179		179			
SM 168.2	254		254			

SM cable gland

	thread	for cable Ø mm	length of thread mm	width across flats mm	connections cast connection box
	M16 x 1.5	5...9	5.0	17	encoder and brake
	M20 x 1.5	9...13	6.0	22	stepper motor phases

metric EMC cable glands:

- protection type IP68 up to 5 bar
- material brass nickel plated
- for shielded cables
- sealing insert made of neoprene
- O-ring on external thread

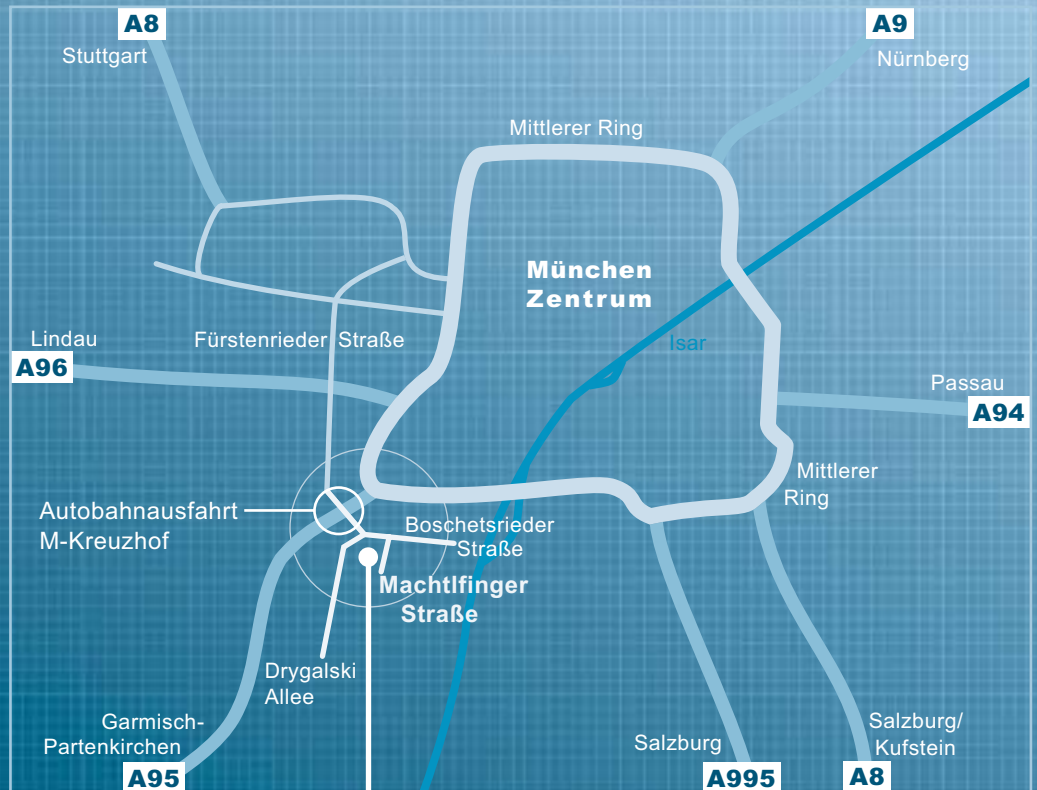

STÖGRA ANTRIEBSTECHNIK GmbH

Machtlfinger Straße 24

D-81379 München

Tel++49-89-15 90 40 00

Fax++49-89-15 90 40 09

E-Mail info@stoegra.de

Internet URL <http://www.stoegra.de>

presented by:

