

ACCU ELECTRIC MOTORS INC

USA: (888) 932-9183

CANADA: (905) 829-2505

- ✓ Over 100 years cumulative experience
- ✓ 24 hour rush turnaround / technical support service
- ✓ Established in 1993



The leading independent repairer of servo motors and drives in North America.

Visit us on the web:

www.servo-repair.com

www.servorepair.ca

www.ferrocontrol.com

www.sandvikrepair.com

www.accuelectric.com

Scroll down to view your document!

For 24/7 repair services :

USA: 1 (888) 932 - 9183

Canada: 1 (905) 829 -2505

Emergency After hours: 1 (416) 624 0386

Servicing USA and Canada

AC SERVOPACK MONITOR PANEL OPERATION MANUAL

SERVOPACK TYPES CACR-SR□BE□, BY□, BD□

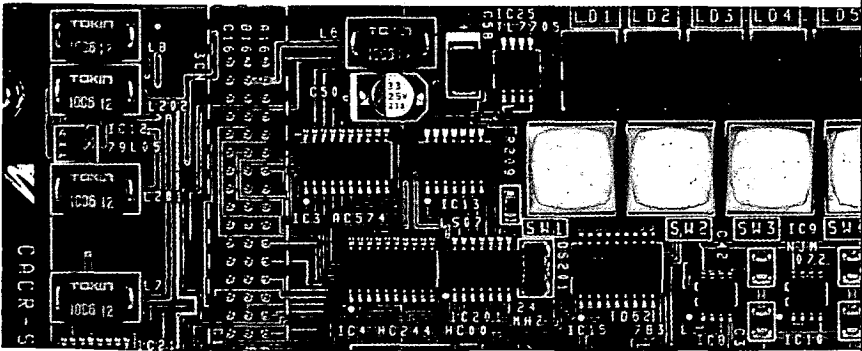

Before initial operation, read these instructions thoroughly, and retain for future reference.



CONTENTS

- 1. SWITCH OPERATION / 1**
- 2. FUNCTIONS OF MONITOR PANEL / 2**
- 3. STATUS INDICATION MODE / 3**
- 4. SETTING MODE / 5**
 - 4.1 USER CONSTANT (DATA) SETUP AND MONITOR / 5
 - 4.2 USER CONSTANT (MEMORY SWITCH) SETUP AND MONITOR / 7
 - 4.3 MONITOR PANEL JOG OPERATION MODE
SELECTION AND OPERATING PROCEDURE / 10
 - 4.4 SPEED REFERENCE OFFSET ADJUSTMENT / 12
 - 4.5 CLEARING FAULT TRACEBACK DATA / 13
 - 4.6 SPEED REFERENCE OFFSET MANUAL ADJUSTMENT / 14
 - 4.7 CURRENT DETECTION OFFSET MANUAL ADJUSTMENT / 16
 - 4.8 CHECK OF MOTOR PARAMETERS / 18
- 5. MONITOR MODE / 20**
- 6. FAULT TRACEBACK MODE / 22**

1 SWITCH OPERATION

Fig. 1.1 shows the monitor panel. The monitor panel has various functions as listed by modes in Par. 2. "Monitor Panel Functions" (P. 2). The functions allotted to SW1 through SW4 vary with monitor panel mode. A description of switch functions according to modes, such as in Fig. 1.2 is provided, and f.1 through f.7 in the description show switch functions in the setup mode.

Notes:

1. The monitor panel's constant setup data are retained even after the power is turned off.
2. Even if the power is turned off after fault occurrence, the fault data is retained in memory. Therefore, it is possible to check the fault data after the power is turned back on.
3. The monitor mode can be changed even during operations.

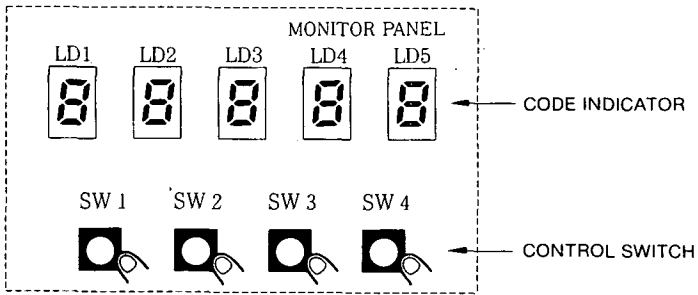

Fig. 1.1 Monitor Panel

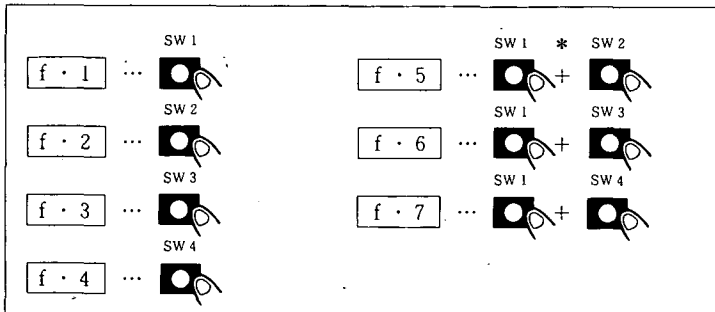

Fig. 1.2 Description of Switch Function

2 FUNCTIONS OF MONITOR PANEL

Table 2.1 shows the monitor panel functions. The status display is the default when control power is turned ON. To change the mode, use switch SW4 as shown in Fig. 2.1.

Table 2.1 Monitor Panel Functions

Mode	Function
State Indication Mode	Various States Indication • Base Block • On Operation • Fault For details, refer to Table 1.2 (See Par. 3.)
Setting Mode	Refer to "User Constant Setting." • Operation (JOG) from Monitor Panel • Speed Reference Offset Adjustment (See Par. 4.2.) (See Par. 4.3.) (See Par. 4.4.)
Monitor Mode	Various Monitoring • Speed • Speed Reference • Torque Reference • Number of Pulses from Origin (Phase-U) (For test by YASKAWA) • Electrical Equipment (For test by YASKAWA) • Interior Status Bit (For test by YASKAWA) (See Par. 5.)
Alarm Traceback Indication Mode	Fault History (See Par. 6.)

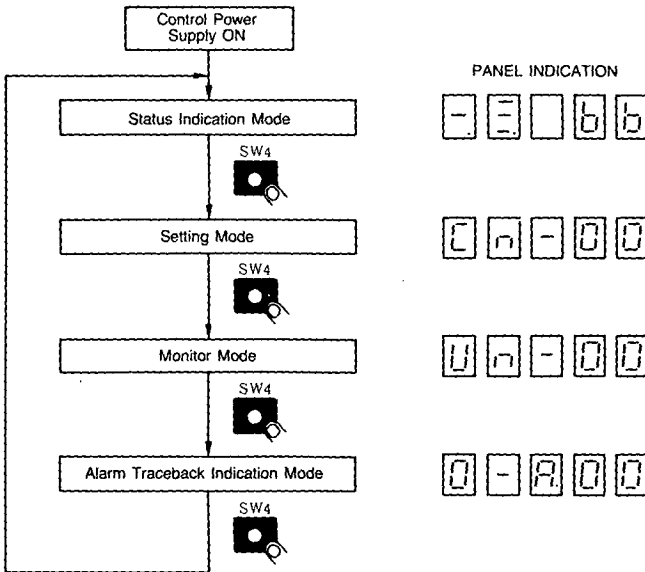

Fig. 2.1 Mode Changeover

3. STATUS INDICATION MODE

When this mode is selected, the condition of Servopack is indicated with bit and code as shown in Fig. 3.1. Table 3.1 shows the bits and the conditions. Fig. 4.1 shows the function allocations of switches.

RST : Becomes alarm reset switch. Alarm **R. I** (overcurrent) cannot be reset.

SET : Changes status indication mode into setting mode.

Panel Display

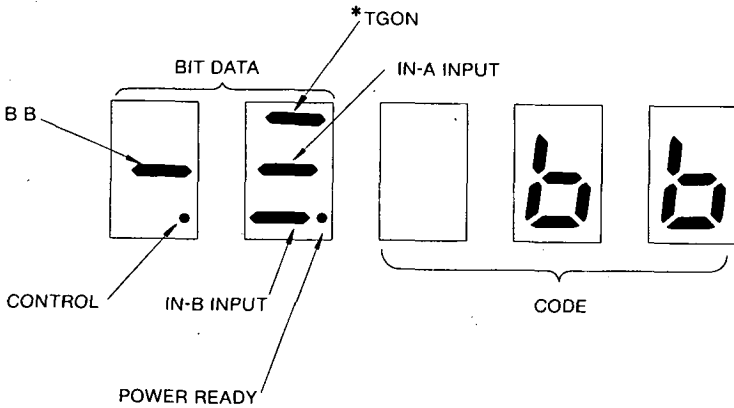

*When brake reference functions is ON (bit E of Cn-01 is set), brake reference ON/OFF signal is displayed.

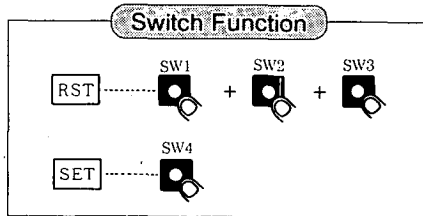

Fig. 3.1 Status Indication

3. STATUS INDICATION MODE (Cont'd)

Table 3.1 Bit Data Contents

Bit Data	Contents
Control ON	Light turns ON with control power ON.
BB	Light turns ON with base block, and turns OFF with Servo ON.
TGON	Light turns ON with motor rotating speed equal to or higher than TGON level (standrad : 20 r/min).
IN-A Input	Light turns ON with IN-A input equal to or higher than TGON level.
IN-B Input	Light turns ON with IN-B input equal to or higher than TGON level.
Power Ready	Light turns ON with main power ON.

Table 3.2 Codes and Status

Code	Status
<i>bb</i>	Base Block
<i>run</i>	On Operation
<i>For</i>	Forward Running Prohibited
<i>rev</i>	Reverse Running Prohibited
<i>R. 00</i>	Alarm Contents Refer to Table 6.1.
<i>R. 01</i>	
<i>1</i>	

4. SETTING MODE

In this mode, the following operations can be performed.

- User constant setup and monitor
- Jog operations from the monitor panel
- Speed reference offset adjustment
- Fault traceback data clearing

4.1 USER CONSTANT (DATA) SETUP AND MONITOR

The switch functions are indicated in Fig. 4.1.

Panel Display

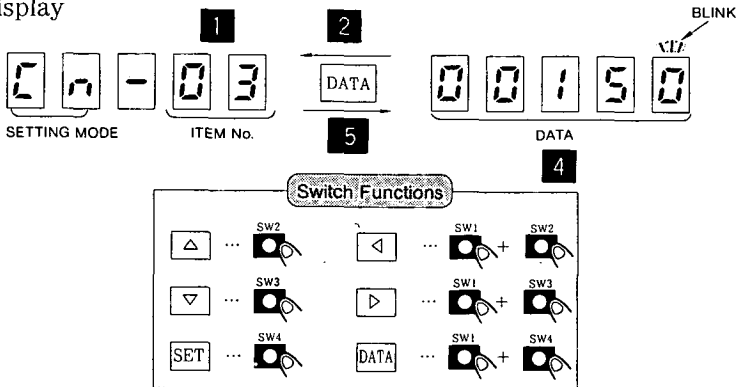

Fig. 4.1 Switch Functions for User Constant Setting

- 1 Set up the item number with the Δ , ∇ , \leftarrow , or \rightarrow key.
 - With the \leftarrow or \rightarrow key, choose a setup digit. The chosen digit then starts blinking to indicate that its numerical value can be changed.
 - With the Δ or ∇ key, increase or decrease the numerical value until the desired value is obtained.
- 2 With the DATA key, display the data related to the selected item number.
- 3 With the Δ , ∇ , \leftarrow , or \rightarrow key, set up the data. (The same operation as stated in 1.)
- 4 Store the data with the SET key.
- 5 With the DATA key, return to the item No. display state.
- 6 Repeat steps 1 through 5 as needed.
- 7 Using the SET key, switch from the setting mode to the monitor mode.

4.1 USER CONSTANT (DATA) SETUP AND MONITOR (Cont'd)

Table 4.1 shows user constants (constant setting).

Table 4.1 User Constants Cn-03 through Cn-12 (Constant Setting) List

	User Constant	Symbol	Name	Unit	Lower Limit	Upper Limit	Setting Prior to Shipping	Remarks
Gains Constants	Cn-03	INBGN	Speed Reference Adjustment Gain	$(r/min)/V$	0	3000	Rating/10V	SRK006
					10			SRK008 or later
	Cn-04*	LOOPHZ	Speed Loop Gain	Hz	20	500	40	SRK006
					1			SRK008 or later
	Cn-05*	PITIME	Speed Loop Integration Time Constant	ms	2	512	20	SRK006
1					10000	SRK008 or later		
Torque Constants	Cn-06	EMGTRO	Emergency Stop Torque	%	0	Max. Torque	Max. Torque	OT Mode
	Cn-08	TLMTF	Forward Running Torque Limit	%	0	Max. Torque	Max. Torque	
	Cn-09	TLMTR	Reverse Running Torque Limit	%	0	Max. Torque	Max. Torque	
	Cn-13	TCRFGN	Torque Reference Gain	$\frac{1}{10} / \text{Rating}$	10	100	30	
	Cn-14	TCRLMT	Speed Limit with Torque Control 1	r/min	0	Max. Speed	Max. Speed	
	Cn-17	TRQFIL	Torque Reference Filter Time Constant	100 μ s	0	250	4	
Sequences Constants	Cn-07	SFSACC	Soft Start Time	ms	0	10000	0	
	Cn-0B	TGONLV	Zero-speed Level	r/min	10	Max. Speed	20r/min	
	Cn-0F	ZCLVL	Zero-clamp Level	r/min	0	100	10	
	Cn-12	BRKTIM	Delay Time from Braking Command to SVOFF	10 ms	0	50	20	
	Cn-15	BRKSPD	Brake Timing at Motor Rotation	r/min	0	Max. Speed	100	
	Cn-16	BRKWAI	Brake Timing at Motor Rotation	10 ms	10	100	50	
Encoder Pulses Constants	Cn-0A ¹	PGRAT	PG Division Ratio	pulses/rev	1	Encoder Number of Pulses	Encoder Number of Pulses	
	Cn-11	PULSNO	Number of Encoder Pulses	Encoder Number of Pulses	—	—	Encoder Number of Pulses	
Other Constants	Cn-0C	TRQMSW	Mode Switch (Torque Reference)	%	0	Max. Torque	200	
	Cn-0D	REFMSW	Mode Switch (Speed Reference)	r/min	0	Max. Speed	0	
	Cn-0E	ACCMSW	Mode Switch (Motor Acceleration Detection)	10 (r/min)/s	0	3000	0	
	Cn-10	JOGSPD	JOG Speed	(r/min)	0	Max. Speed	100	

*In Cn-04 and Cn-05, upper/lower limit values differ according to software version number. (SRK006 and SRK008 are software version numbers).

¹ In Cn-0A, turn the control power ON again after setting.

4.2 USER CONSTANT (MEMORY SWITCH) SETUP (Cn-01 to Cn-02) AND MONITOR

User constants Cn-01 and Cn-02 can be set up or checked as memory switch bits. The procedures for item number setup and data display are the same as indicated in Par. 4.1 **1** and **2**.

The switch functions provided after bit data display are indicated in Fig. 4.2.

When changing constants Cn-01 and Cn-02, functions become available by turning ON control power supply again.

Panel Display

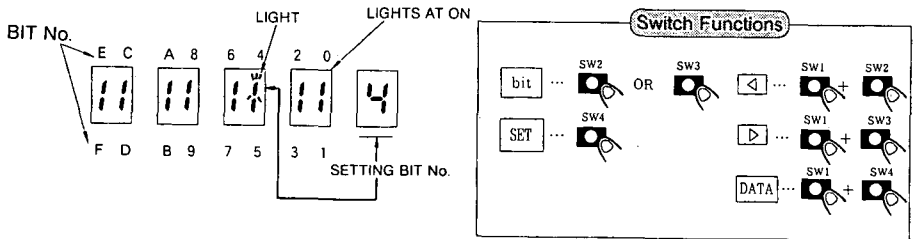

Fig. 4.2 Switch Functions Provided after Bit Data Display

- 1** With the or key, enter the setup memory switch number at the far right end of the panel.
- 2** With the key, set the memory switch to ON or OFF (either switch SW2 or SW3 can be used). The panel indication comes on when the switch is ON, and goes off when the switch is OFF.
- 3** Repeat steps **1** and **2** as needed.
- 4** With the key, return to the item No. display state.
- 5** Using the key, switch from the setting mode to the monitor mode.

Table 4.2 shows memory switches of user constant Cn-01, and Table 4.3 those of user constant Cn-02.

4.2 USER CONSTANT (MEMORY SWITCH) SETUP (Cn-01 to Cn-02) AND MONITOR (Cont'd)

Table 4.2 User Constant Cn-01 (Memory Switch)

Selection	Bit No.	Setting	Conditions	Standard
Sequence Input Selection	0	0	Servo ON/OFF by external input (SV-ON).	0
		1	The servo is ON at all times.	
	1 (SR _{LB} Y only)	0	The external input (SEN) is used.	0
		1	Regardless of the SEN signal presence, the Servopack automatically concludes that the "H" level prevails.	
	2	0	The P-OT signal prohibits forward running.	0
		1	Forward running is permitted at all times.	
	3	0	The N-OT signal permits reverse running.	0
		1	Reverse running is permitted at all times.	
Input Signal Selection	4	0	The IN-A input is used.	0
		1	Regardless of the IN-A input presence, the Servopack concludes that the IN-A input is 0.	
	5	0	The IN-B input is used.	0
		1	Regardless of the IN-B input presence, the Servopack concludes that the IN-B input is 0.	
Abnormal Stop Selection	6	0	<DB stop> The dynamic brake stops the motor.	0
		1	<Coasting to stop> The motor is freed and brought to a stop.	
	7	0	<DB OFF after DB stop> The dynamic brake is turned OFF after the motor is stopped.	0
		1	<DB continuously ON after DB stop> The dynamic brake remains activated after the motor is stopped.	
	8 ^{Note 1}	0	The overtravel state stop method agrees with bit 6.	0
		1	<Overtravel zero speed stop> In the overtravel state, the motor is stopped at the torque setting defined by user constant Cn-06.	
	9 ^{Note 2}	0	In the overtravel state, base blocking (BB) is implemented after the motor stops.	0
		1	In the overtravel state, zero clamping is effected after zero speed stop.	
Mode Switch Selection (for Speed Control only)	D-C ^{Note 3}	0-0	<Torque reference> Based on the torque reference level defined by user constant Cn-0C.	00
		0-1	<Speed Reference> Based on the speed reference level defined by user constant Cn-0D.	
		1-0	<Acceleration> Based on the acceleration level defined by user constant Cn-0E.	
		1-1	<None> The mode switch function is not provided.	
Presence of External Brake	E	0	The braking command function is not provided.	0
		1	The braking command function is provided.	
Overload Alarm Selection	F	0	The overload alarm function is not provided.	0
		1	The overload alarm function is provided.	

- Notes: 1. The abnormal stop method in the torque control mode complies with bit 6.
 2. Selects the status based on the stop method selected for the overtravel state (bit 8).
 3. Selects a mode switch operating condition. When the mode switch operates, the speed control mode changes to P control. However, this is effective for speed control only.

Table 4.2 User Constant Cn-01 (Memory Switch) List (Cont'd)

Selection	Bit No.	Setting	Description	Reference Input	Sequence Signal Input	Standard
Control Mode Selection	B • A	0 • 0	<p><Speed control></p> <ul style="list-style-type: none"> Regular speed control. The $\overline{P-CON}$ signal (1CN-24) is used to effect P/Pi control changeover. 	Speed reference (IN-A) Auxiliary reference input (IN-B)	$\overline{P-CON}$ OFF: PI control. ON: P control	0 • 0
		0 • 1	<p><Zero clamp speed control></p> <ul style="list-style-type: none"> After the motor is stopped (ZCLVL), the speed reference is disconnected to execute the zero speed stop function. The $\overline{P-CON}$ signal (1CN-24) is used to turn ON and OFF the zero clamp function. 		$\overline{P-CON}$ OFF: Zero clamp function OFF ON: Zero clamp function ON	
		1 • 0	<p><Torque control I></p> <ul style="list-style-type: none"> The motor output torque is controlled by the torque reference (IN-A). The IN-B cannot be used. 	Torque reference (IN-A)	None	
		1 • 1	<p><Torque control II></p> <ul style="list-style-type: none"> The $\overline{P-CON}$ signal (1CN-24) is used for torque/speed control mode changeover. <p>Torque control mode</p> <ul style="list-style-type: none"> The motor output torque is controlled by the torque reference (IN-B). The speed limit can be entered from outside (IN-A). The IN-A voltage (+) limits both the forward and reverse running speeds. <div style="text-align: center;"> </div> <p>Speed control mode</p> <ul style="list-style-type: none"> The speed reference is entered from the IN-A. The IN-B cannot be used. 	Torque control mode Torque reference (IN-B) Speed limit (IN-A)	$\overline{P-CON}$ OFF: Torque control ON: Speed control	
For Cn-02	Reverse Rotation Mode Selection	0	0.	CCW: Forward Running		0
		1	1	CW: Forward Running		
	Encoder Error Detection	1 (SRLBY only)	0	Detects an encoder error.		
		1	1	Does not detect an encoder error.		
Spare	2 to F		Do not adjust.			

4.3 MONITOR PANEL JOG OPERATION MODE SELECTION AND OPERATING PROCEDURE

(1) Monitor Panel Jog Operation Mode Selection

When user constant Cn-00 is set to 00, the operations are to be controlled from the monitor panel. The switch functions are indicated in Fig. 4.3.

Panel Display

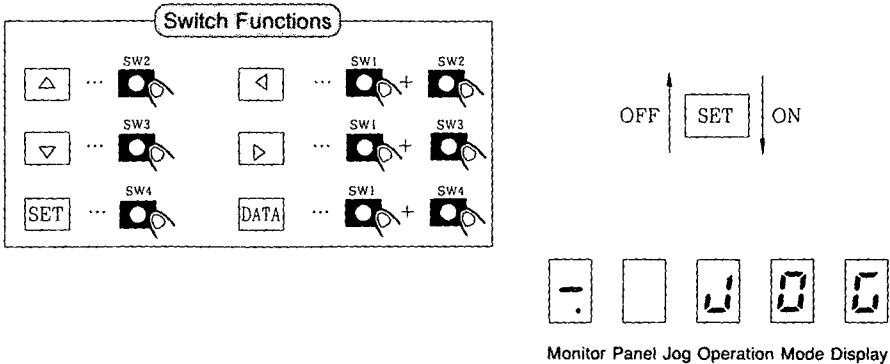

Fig. 4.3 Switch Functions in Monitor Panel Jog Operation Mode

- 1 Select item number 00 with the Δ , ∇ , \triangleleft or \triangleright key.
- 2 With the DATA key, display the data related to the selected item number.
- 3 With the Δ , ∇ , \triangleleft or \triangleright key, select the number 00.
- 4 With the SET key, turn ON or OFF the monitor panel jog operation mode.
- 5 With the DATA key, return to the item No. display status.
- 6 Using the SET key, switch from the setting mode to the monitor mode.

(2) Monitor Panel Jog Operation Procedure

For speed reference adjustment, use user constant Cn-10 (see Par. 4.1).

The switch functions provided for monitor panel jog operations are indicated in Fig. 4.4.

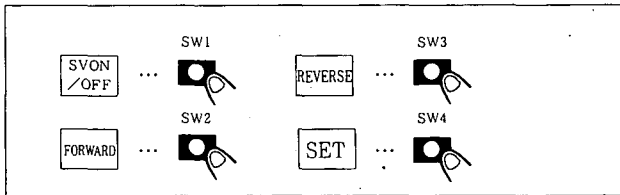

Fig. 4.4 Switch Functions for Monitor Panel Jog Operations

- 1 With the **[SVON/OFF]** switch, effect SVON/SVOFF changeover.
- 2 The motor runs in the forward direction while the **[FORWARD]** key is held down.
- 3 The motor runs in the reverse direction while the **[REVERSE]** key is held down.
- 4 The **[SET]** key is used to switch from the monitor panel jog operation mode to the user constant Cn-00 data display status.
- 5 With the **[DATA]** key, return to the item No. display status.
- 6 Using the **[SET]** key, switch from the setting mode to the monitor mode.

4.4 SPEED REFERENCE OFFSET ADJUSTMENT

When user constant Cn-00 is set to 01, the system enters the speed reference offset adjustment mode. The switch functions are indicated in Fig. 4.5.

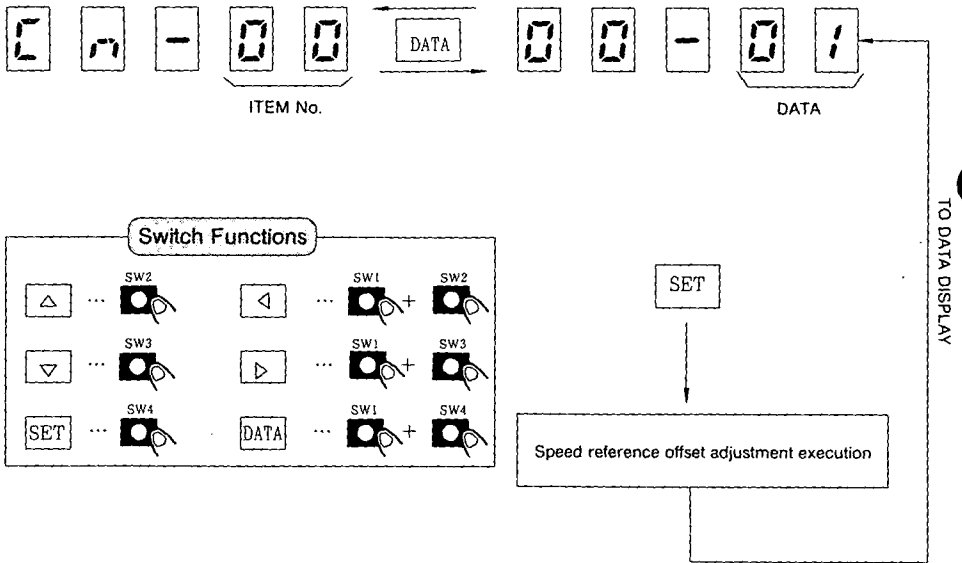

Fig. 4.5 Speed Reference Offset Adjustment

- 1** Select the item number 00 with the , , or key.
- 2** With the key, display the data related to the selected item number.
- 3** With the , , or key, select the number 01.
- 4** Apply a desired zero speed reference voltage between speed reference input terminals IN-A and IN-B (a voltage of 0V should normally be applied).
- 5** With the key, make speed reference offset adjustment and return to the user constant Cn-00 data display status.
- 6** With the key, return to the item No. display status.
- 7** Using the key, switch from the setting mode to the monitor mode.

4.5 CLEARING FAULT TRACEBACK DATA

When user constant Cn-00 is set to 02, fault traceback data are cleared. The switch functions are indicated in Fig. 4.6.

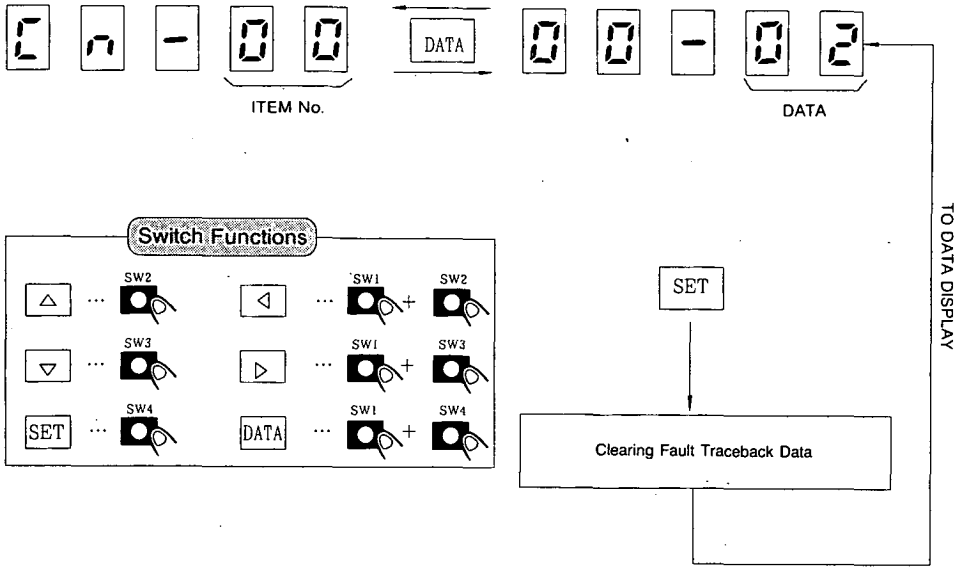

Fig. 4.6 Speed Reference Offset Adjustment

- 1 Select the item number 00 with the \triangle , ∇ , \triangleleft or \triangleright key.
- 2 With the DATA key, display the data related to the selected item number.
- 3 With the \triangle , ∇ , \triangleleft or \triangleright key, select the number 02.
- 4 With the SET key, clear fault traceback data and return to the user constant Cn-00 data display status.
- 5 With the DATA key, return to the item No. display status.
- 6 Using the SET key, switch from the setting mode to the monitor mode.

4.6 SPEED REFERENCE OFFSET MANUAL ADJUSTMENT

(1) Mode Setting in Speed Reference Offset Manual Adjustment

When user constant Cn-00 is set to 03, the system enters the speed reference offset manual adjustment mode. The switch functions are shown in Fig. 4.7.

Panel Indication

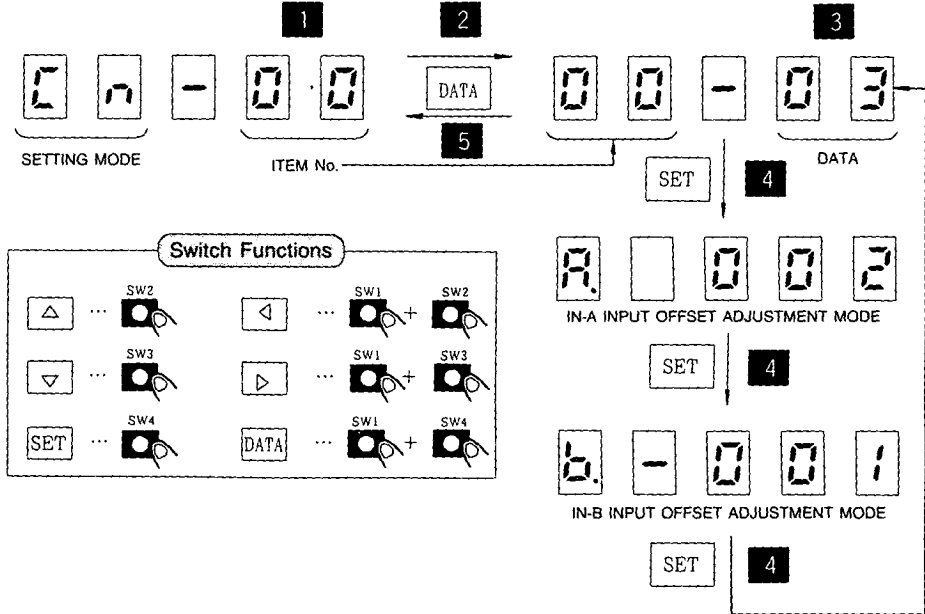

Fig. 4.7 Switch Functions in Speed Reference Offset Manual Adjustment Mode

- 1** Set up item number 00 with , , , or key.
- 2** With the key, display the data related to the selected item number.
- 3** With the , , , or key, select the number 03.
- 4** With the key, switch the adjustment mode.
- 5** With the key, return to the item No. display status.
- 6** Using the key, switch from the setting mode to the monitor mode.

(2) Speed Reference Offset Manual Adjustment

Input a voltage that will obtain zero speed reference to the speed reference input terminals IN-A and IN-B (Normally 0V).

The switch functions in the reference offset manual adjustment mode are shown in Fig. 4.8.

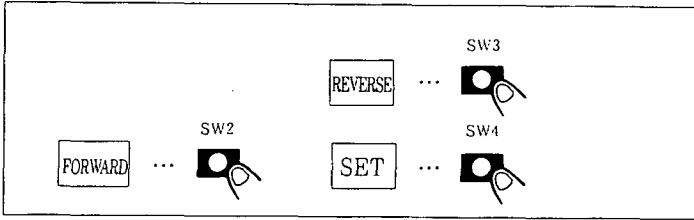

Fig. 4.8 Switch Functions in Speed Reference Offset Manual Adjustment Mode

- 1** While the **FORWARD** key is held down, the offset is added to the forward running side.
- 2** While the **REVERSE** key is held down, the offset is added to the reverse running side.
- 3** Use the **SET** key, store offset data, then enter the next mode.

Offset adjustment is performed so that the LED indication may basically become zero; however, the perfect zero state of indication does not always offer optimum adjustment. Therefore, adjust the offset carefully, taking actual motor motion into consideration.

4.7 CURRENT DETECTION OFFSET MANUAL ADJUSTMENT

(1) Mode Setting in Current Detection Offset Adjustment

When user constant Cn-00 is set to 04, the system enters the current detection offset adjustment mode. The switch functions are shown in Fig. 4.9.

Panel Indication

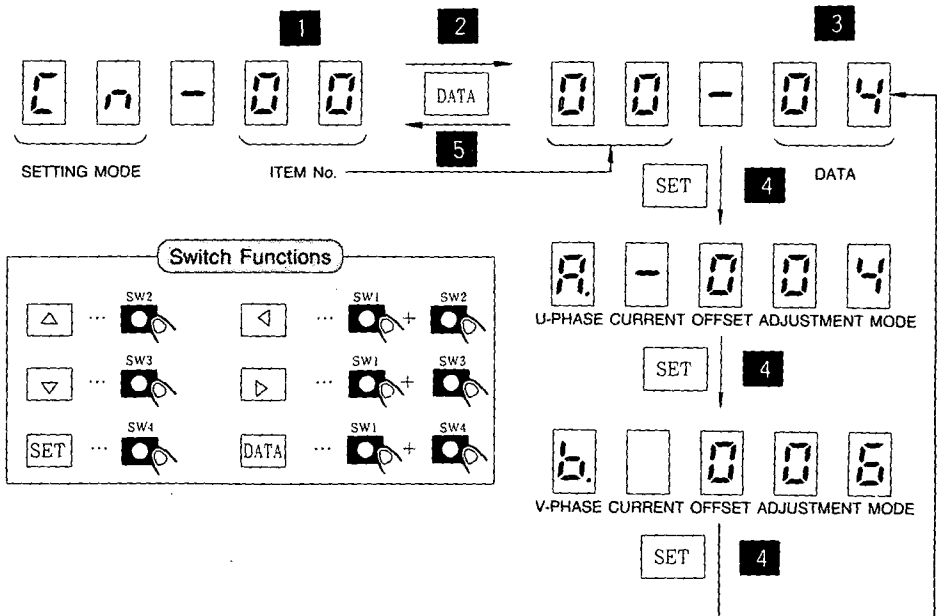

Fig. 4.9 Switch Functions in Current Detection Offset Adjustment Mode

- 1** Set up item number 00 with Δ , ∇ , \leftarrow , or \rightarrow key.
- 2** With the **DATA** key, display the data related to the selected item number.
- 3** With the Δ , ∇ , \leftarrow , or \rightarrow key, select the number 03.
- 4** With the **SET** key, switch the adjustment mode.
- 5** With the **DATA** key, return to the item No. display status.
- 6** Using the **SET** key, switch from the setting mode to the monitor mode.

(2) Current Detection Offset Adjustment

The current detection offset is adjusted at the factory prior to shipment: the user, in principal, doesn't need to adjust it.

However, if adjustment of higher accuracy is required due to a Servopack-motor combination, perform adjustment as follows:

The switch functions in the current detection offset adjustment mode are shown in Fig. 4.10.

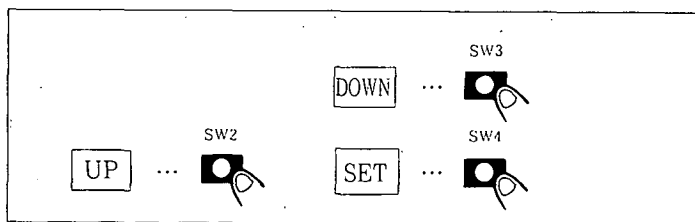

Fig. 4.10 Switch Functions in Current Detection Offset Adjustment Mode

- 1** Rotate the motor at about 100 r/min, and monitor the torque monitor terminal MON1 using an oscilloscope.
- 2** Depressing the **UP** or **DOWN** key, perform adjustment so as to have a minimum torque ripple. LED indication shows offset data.
- 3** With the **SET** key, store offset data, then enter the next mode.
- 4** Because torque ripple must be adjusted with a good balance between U-phase and V-phase offsets, repeat steps **2** and **3** several times, to make sure of an optimum value.

4.8 CHECK OF MOTOR PARAMETERS

(1) Check Method of Motor Parameters

When user constant Cn-00 is set to 05, the system enters the motor parameter check mode.

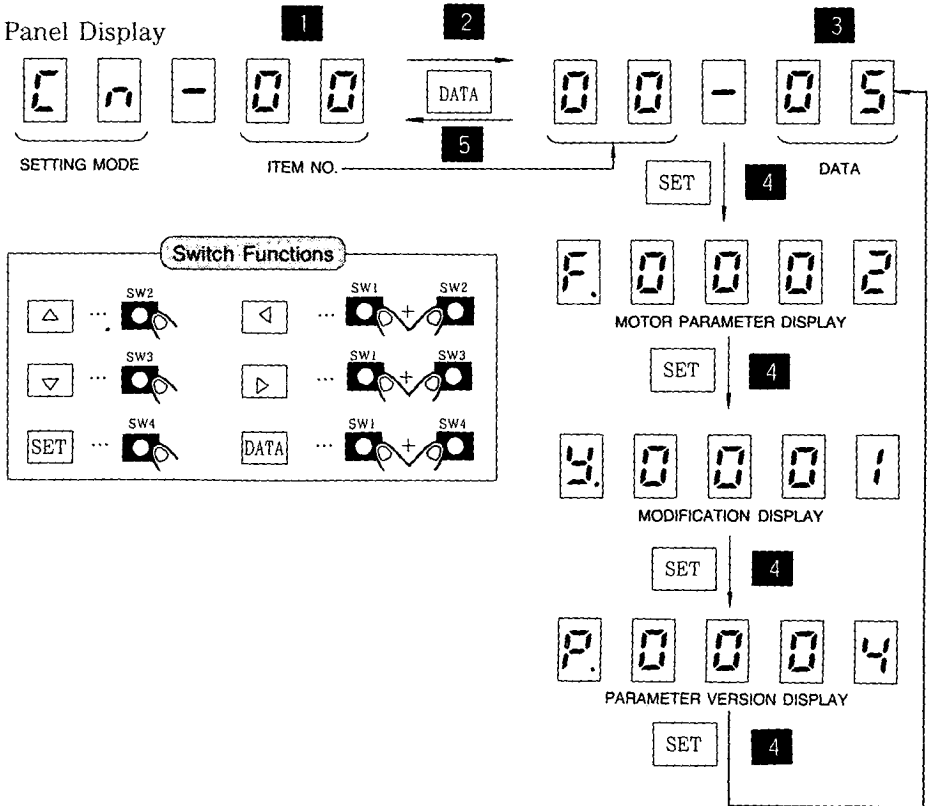
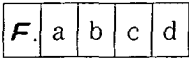

Fig. 4.11 Switch Functions in Motor Parameter Check

- 1** Set up item number 00 with , , , or key.
- 2** With the key, display the data related to the selected item number.
- 3** With the , , , or key, select the number 05.
- 4** With the key, check the motor parameter.
- 5** With the key, return to the item No. display status.
- 6** Using the key, switch from the setting mode to the monitor mode.

(2) Parameter Display

Motor Parameter



Motor Capacity (Hexadecimal display)

$$(C \times 16 + d) \times 100 \text{ [W]}$$

Nos. corresponding to Alphabets

A = 10

b = 11

C = 12

d = 13

E = 14

F = 15

Motor Type

0: M Series

1: F Series

2: S Series

4: D Series

5: G Series

Encoder Type

0: Incremental Encoder

1: Absolute Encoder

2: Incremental Encoder

3: Absolute Encoder

Motor Capacity Display

Capacity	Display		
200W	F.		0 2
300W	F.		0 3
500W	F.		0 5
700W	F.		0 7
900W	F.		0 9
1.0kW	F.		0 A
1.2kW	F.		0 C
1.5kW	F.		0 F
2.0kW	F.		1 4
3.0kW	F.		1 E
4.4kW	F.		2 C
6.0kW	F.		3 C

Modification Index

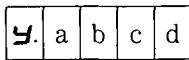

Modification No.

Parameter Version Display

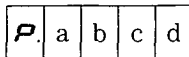

Parameter Version

5. MONITOR MODE

In this mode, the speed reference, torque reference, and other data can be observed on the monitor panel.

Table 5.1 lists the data that can be monitored. The switch functions are indicated in Fig. 5.1.

Table 5.1 Data Monitored

Monitor No.	Data Monitored
00	Feedback Speed (r/min)
01	Speed Reference (r/min)
02	Torque Reference (%)
03	No. of Pulses from Phase-U edge (Phase-U) (For test by YASKAWA)
04	Electrical Angle (deg) (For test by YASKAWA)
05	Internal Status Bit Display (Refer to Table 5.2.) (For test by YASKAWA)

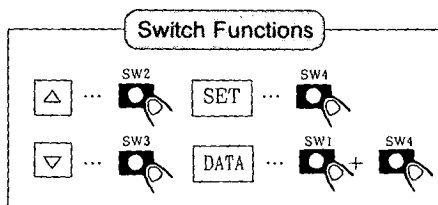
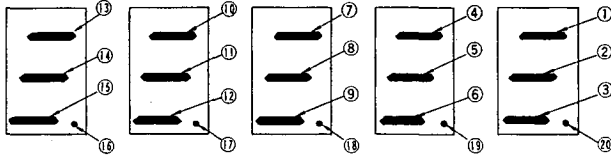

Fig. 5.1 Switch Functions in Monitor Mode

- 1 With the Δ or ∇ key, select a desired monitor No.
- 2 With the DATA key, initiate monitor display.
- 3 Using the DATA key, return to the monitor No. selection state.
- 4 With the SET key, switch from the monitor mode to the fault traceback mode.

Table 5.2 Bit Indication of Monitor Board Un-05 Internal Status



Bit. No.	Symbol	Contents
①	SVALM	Servo Alarm
②	DBON	Dynamic Brake ON
③	DIR	Reverse Run Mode
④	CLT	Current Limit
⑤	TGON	Motor Running
⑥	MSON	Mode Switch ON
⑦	ACON	AC Power Supply ON
⑧	SVRDY	Servo Ready
⑨	B-ON	Motor Under Current Conduction
⑩	PA	Phase-A
⑪	PB	Phase-B
⑫	PC	Phase-C
⑬	PU	Phase-U
⑭	PV	Phase-V
⑮	PW	Phase-W
⑯	SVON	Servo ON
⑰	P-CON	PI Operation Input
⑱	P-OT	Forward Running Prohibit Input
⑲	N-OT	Reverse Running Prohibit Input
⑳	SEN	SEN Signal Input (-SR:BY only)

6. FAULT TRACEBACK MODE

In this mode, the information on past fault occurrences can be displayed.

- The information on up to 10 past fault occurrences can be stored.
- When a fault is reset or the control power is turned on, traceback data A. 99 is saved (These data are also counted as one of a total of 10 stored items of fault information).
- For the relationship between traceback data and fault descriptions, refer to Table 6.1. The switch functions are indicated in Fig. 6.1.

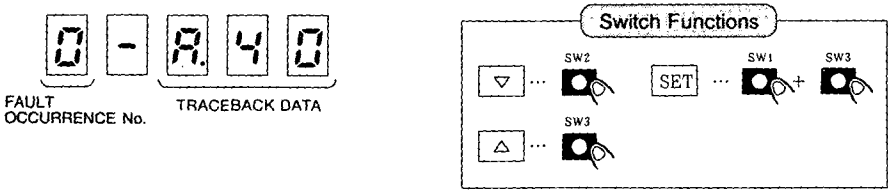

Fig. 6.1 Switch Functions in Fault Traceback Mode

- 1 With the ∇ or Δ key, increase or decrease the fault occurrence number. The fault information related to the selected number is then displayed. (The higher the fault occurrence number, the older the fault occurrence.)
- 2 With the SET key, switch from the fault traceback mode to the status display mode.

Table 6.1 Trouble Indications with Monitor Panel and Traceback Data

Monitor Panel Indication (Traceback Data)	Detection
R. 00	Encoder transmission error (only for type SR□□BY)
R. 02	Parameter breakdown
R. 03	Main circuit detection error
R. 04	Parameter setting error
R. 10	Overcurrent or heatsink overheat or ground fault
R. 20	MCCB trip
R. 30	Regeneration error
R. 40	Overvoltage
R. 51	Feedback overspeed
R. 60	Undervoltage
R. 71	Momentary overload
R. 72	Continuous overload
R. 80	Encoder error (only for type SR□□BY)
R. 81	Encoder backup error (only for type SR□□BY)
R. 82	Encoder checksum error (only for type SR□□BY)
R. 83	Encoder battery error (only for type SR□□BY)
R. 84	Encoder absolute error (only for type SR□□BY)
R. 85	Encoder overspeed (only for type SR□□BY)
R. b1	Reference input read error
R. b2	External current limit read error
R. C1	Overrun (wrong wiring of motor circuit PG signal line)
R. C2	Phase detection error (wrong wiring or disconnection of PG signal line: PU, PV, PW)
R. C3	PA,PB-phase disconnection of PG signal line
R. C4	PC disconnection of PG signal line
R. F1	Open phase of power supply
R. F2	Power supply rise error
—	CPU error (LD1 indicates □.)

6. FAULT TRACEBACK MODE (Cont'd)

Table 6.2 User-setup Parameter Memorandum

User Constant	Date of Change																				
	Bit No.	Contents																			
Cn-01	0	SV-ON Mask																			
	1	SEN Mask																			
	2	P-OT Mask																			
	3	N-OT Mask																			
	4	IN-A Mask																			
	5	IN-B Mask																			
	6	Coasting to a stop/DB stop																			
	7	DB ON/OFF after Stop																			
	8	OT Zero Speed Stop																			
	9	Zero Clamp after OT Stop																			
	A	Control Mode Selection																			
	B																				
	C																				
	D		Mode Switch Selection																		
	E	Braking Command Selection																			
	F	Multi-turn Data Clear																			
Cn-02	0	Reverse Rotation Mode																			
	1	Encoder Error Detection																			
Cn-03		IN-B Input Adjustment [(r/min)/V]																			
Cn-04		Speed Loop Gain [Hz]																			
Cn-05		Speed Loop Integral Time Constant																			
Cn-06		Emergency Stop Torque																			
Cn-07		Soft Start Time																			
Cn-08		Forward Torque Limit [%]																			
Cn-09		Reverse Torque Limit [%]																			
Cn-0A		PG Frequency Dividing Ratio Setting																			
Cn-0B		Zero-speed Level [r/min]																			
Cn-0C		Mode Switch (Torque Reference) [%]																			
Cn-0D		Mode Switch (Speed Reference) [r/min]																			
Cn-0E		Mode Switch (Motor Acceleration Detection) [10 (r/min)/s]																			
Cn-0F		Zero-clamp Level [r/min]																			
Cn-10		JOG Speed [r/min]																			
Cn-11		Number of Encoder Pulses [pulses/rev]																			
Cn-12		Delay Time from Brake Reference ($\times 10$ ms)																			
Cn-13		Torque Reference Gain [1/10 V Rated Torque]																			
Cn-14		Speed Limit [r/min]																			
Cn-15		Brake Timing (Speed) [r/min]																			
Cn-16		Brake Timing (Time) [r/min]																			
Cn-17		Torque Reference Filter [$\times 100$ μ s]																			

NOTES

AC SERVOPACK MONITOR PANEL OPERATION MANUAL

TOKYO OFFICE New Pier Takeshiba South Tower, 1-15-1, Kaigan, Minatoku, Tokyo 105 Japan
Phone 81-3-5402-4511 Fax 81-3-5402-4580

YASKAWA ELECTRIC AMERICA, INC.

Chicago-Corporate Headquarters 2942 MacArthur Blvd. Northbrook, IL 60062-2028, U.S.A.

Phone 1-847-291-2340 Fax 1-847-496-2430

Chicago-Technical Center 3160 MacArthur Blvd. Northbrook, IL 60062-1917, U.S.A.

Phone 1-847-291-0411 Fax 1-847-291-1018

MOTOMAN INC.

805 Liberty Lane West Carrollton, OH 45449, U.S.A.

Phone 1-513-847-6200 Fax 1-513-847-6277

YASKAWA ELÉTRICO DO BRASIL COMÉRCIO LTDA.

Avenida Brigadeiro Faria Lima 1064-S/CJ 504/511, São Paulo, Brazil

Phone 55-11-815-7723 Fax 55-11-870-3849

YASKAWA ELECTRIC EUROPE GmbH

Am Kronberger Hang 2, 65624 Schwalbach, Germany

Phone 49-6196-569-300 Fax 49-6196-868-301

Motoman Robotics AB

Box 504 S38525 Torsås, Sweden

Phone 46-486-10575 Fax 46-486-41410

Motman Robotec GmbH

Kammerfeldstraße 1, 85391 Allershausen, Germany

Phone 49-8166-900 Fax 49-8166-9039

YASKAWA ELECTRIC UK LTD.

3 Drum Mains Park Orchardton Woods Cumbernauld, Scotland, G68 9LD U.K.

Phone 44-1236-735000 Fax 44-1236-458182

YASKAWA ELECTRIC KOREA CORPORATION

Paik Nam Bldg 901 188-3, 1-Ga Euljiro, Joong-Gu Seoul, Korea

Phone 82-2-775-7844 Fax 82-2-753-2639

YASKAWA ELECTRIC (SINGAPORE) PTE. LTD.

151 Lorong Chuan, #04-01, New Tech Park Singapore 556741, Singapore

Phone 65-282-3003 Fax 65-289-3003

YATEC ENGINEERING CORPORATION

Shen Hsiang Tang Sung Chiang Building 10F 146 Sung Chiang Road, Taipei, Taiwan

Phone 886-2-563-0010 Fax 886-2-567-4877

BEIJING OFFICE Room No. 301 Office Building of Beijing International Club, 21 Jianguomenwai Avenue, Beijing 100020, China

Phone 86-10-532-1850 Fax 86-10-532-1851

SHANGHAI OFFICE Room No. 8B Wan Zhong Building 1303 Yan An Road (West), Shanghai 200050, China

Phone 86-21-6212-1015 Fax 86-21-6212-1326

YASKAWA JASON (HK) COMPANY LIMITED

Rm. 2915, Hong Kong Plaza, 185-191, Cornnaught Road West, Hong Kong

Phone 852-2859-3220 Fax 852-2547-5773

TAIPEI OFFICE Shen Hsiang Tang Sung Chiang Building 10F 146 Sung Chiang Road, Taipei, Taiwan

Phone 886-2-563-0010 Fax 886-2-567-4677



YASKAWA ELECTRIC CORPORATION

YASKAWA

TOE-S800-11.3D

© Printed in Japan August 1996 92-1 3WA

592-247