

ACCU ELECTRIC MOTORS INC

USA: (888) 932-9183

CANADA: (905) 829-2505

- ✓ Over 100 years cumulative experience
- ✓ 24 hour rush turnaround / technical support service
- ✓ Established in 1993



The leading independent repairer of servo motors and drives in North America.

Visit us on the web:

www.servo-repair.com

www.servorepair.ca

www.ferrocontrol.com
www.sandvikrepair.com
www.accuelectric.com

Scroll down to view your document!

For 24/7 repair services :

USA: 1 (888) 932 - 9183

Canada: 1 (905) 829 -2505

Emergency After hours: 1 (416) 624 0386

Servicing USA and Canada

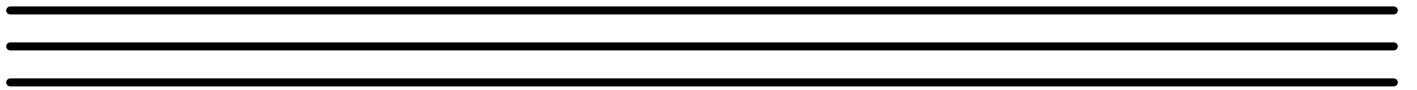

S–BTS 10 R–Series
Smart Brushless Servo Amplifier

Installation & Operating Manual

BALDOR ASR GmbH owns the copyright of this document, which is supplied to customers of the company on the understanding, that it will not be reproduced, or disclosed in whole or in part, without the express permission of BALDOR ASR GmbH.

© 1989

Warning!

These instructions are for use by qualified personnel only.

In order to avoid electrical shock, do not perform any servicing other than that contained in the Operating and Service Manual unless you are qualified to do so.

Dangerous voltage exists on the screw terminals of power inlet and outlet when energized. Exercise extreme care when working on an energized circuit.

When a unit needs to be replaced, wait at least 2 minutes to allow a discharge of the power-capacitors and touch only the handle on the front-side. Use isolated tools for removal of connecting wires and avoid to touch the contacts.

Change Notice

This reprint V 1.5 includes the following changes:

- Page 4 - Drawing updated
- Page 5 - Drawing updated
- Page 13 - Default Parameter on Floppy Disk added
- Page 14/16 - i46/i48 exchanged
- Page 17 - "i12 ≥ 100 for BSM 6 R" added
- Page 25 - Drive Disable Input Filter
 - Aux. Input Assignment
 - 24 V Input Power added

Contents

	Chapter	Page
Specifications		1
Specifications (Continued)	1.1	
S-BTS 10 R Functional Blockdiagram		2
Dimensions S-BTS 10 R		3
Interconnection Diagram		4
System Connection Diagram		5
RSBTS 10 Backpanel Detailed		6
RSBTS 10 Backpanel Full Size		7
Set-Up Procedure		8
E-Points	1	8/9
μSMCC Component Layout		10
Card Address and Baud Rate Setting	2	11
RS232 Interface to Host	3	12
Multi Axis S-BTS 10 R	4	12
Set-Up (Continued)	5	13
Set-Up (Continued)	6	13
i-Parameter Standard (Non-Parabolic)	6	14/15
i-Parameter Standard (Parabolic)	6	16/17
Set-Up (Continued)	7	17
Preventing Start-Up-Phasing Jump (Non Parabolic)	8.1	18
Preventing Start-Up-Phasing Jump (Parabolic)	8.2	19
Set-Up Procedure (Continued)	9/10	20
S-BTS 10 R Testpoints		21/22
Testpoints & Potentiometer Location on Control Card		23
I/O Hardware: Inputs		24/25
I/O Hardware: Outputs		26/27

Contents (Continued)

	Chapter	Page
I/O Hardware: RS232		28
J-Expansion Pin Assignment		29
Control Card Component Layout		30
BPS 10 R General		31
BPS 10 R Circuit Diagram		32
BPS 10 R Dimensions		33
BPS 10 R Component Layout		34
Transformer Dimensions		35
S-BTS 10 R Protection-Chokes		36
320 W Load Resistor (Optional)		37
S-BTS 10 R User Notes (Notes 1 - 4)		38
S-BTS 10 R User Notes (Notes 5/6)		39
S-BTS 10 R User Notes (Notes 6/7)		40

S-BTS 10 R

Servo Positioner Specification Sheet

PARAMETER	Units	200-2.5	200-5	200-10	200-15	200-22.5
GENERAL						
Nominal DC Bus Voltage ¹	V DC	200.0				
Voltage Range	V DC	160 - 240				
Nominal Output Voltage	V AC	130.0				
Cont. Phase Current	A(rms)	2.5	5.0	10.0	15.0	22.5
Max. Peak Current	A(rms)	5.0	10.0	20.0	30.0	45.0
Cont. Output Power	kW	0.6	1.2	2.4	3.7	5.5
Switching Frequency	kHz	10.5	10.5	10.5	10.5	10.5
MECHANICAL						
Mounting Dimensions	6 HE mm	Rack 220x60				Rack 220x120
Weight	kg	2.0				4.0

POWER SUPPLY BPS 10 R	Units	200-020 R	200-040 R	200-060 R
Input Voltage	3 phase V AC	140.0		
Output Voltage	V DC	200.0		
Cont. Output Current	A	20.0	40.0	60.0
Max. Output Current	A	40.0	80.0	120.0
Nominal Power	2.5 s kW	4.0	8.0	12.0
Regeneration Switching Current	A	20.0	20.0	20.0
Regeneration Resistor (internal ²)	W	80.0	80.0	80.0
MECHANICAL				
Mounting Dimensions	mm	Rack 6 HE 220 x 60		
Weight	kg	1.0		
TEMPERATURE S-BTS/BPS 10 R				
Ambient for nominal ratings	deg.C	25		
Operating Range	deg.C	0 to +45		
Storage	deg.C	-20 to +70		

¹ 24/48 V also available

² or 320 W external on order

S-BTS 10 R

Servo Positioner Specification Sheet

POSITIONING/VELOCITY LOOP

SERVO PERFORMANCE

Normal mode	500 microseconds
Handwheel mode only	150 microseconds
Execution Rate	200 Blocks/second

POSITIONING LOOP

Range	+/- 67 million encoder counts
Accuracy	+/- one encoder count

VELOCITY LOOP

Range	.005 to 1 200 000 encoder counts/s
Accuracy (long term)	0.002 %
(short term)	0.5 % to 1 %
Repeatability	0.001 %

ELECTRICAL

Digital In-Outputs	TTL Compatible
Aux. Function (inputs)	0 to +5 Volt
(outputs)	12 V 100 mA sink
Interface	RS232
Memory Capacity	32 k ROM, 8 k RAM, 8 k EEROM

POSITIONING FEEDBACK (Resolver)

Resolution	1024 pulses per revolution
Accuracy	+/- 10 min.
Max. input rate	1 000 000 counts/second

HANDWHEEL ENCODER

Signal	Line Receiver 5 V TTL
Max. input rate	600 000 counts/second

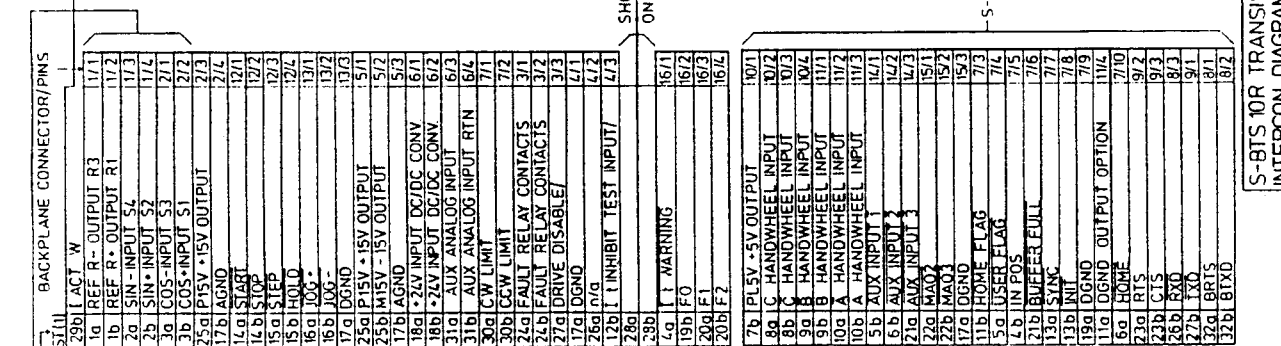

BACKPLANE CONNECTOR/PINS	FUNCTION	RESOLVER SIGNALS
1/1	REF R- OUTPUT R3	
1/2	REF R- OUTPUT R1	
1/3	SIN- INPUT S4	
1/4	SIN- INPUT S2	
2/1	COS- INPUT S3	
2/2	COS- INPUT S1	
2/3	P15V *15V OUTPUT	
2/4	AGND	
12/1	START	
12/2	STOP	
12/3	STEP	
12/4	HOLD	
13/1	LOG *	
13/2	LOG -	
13/3	DGND	
5/1	P15V *15V OUTPUT	
5/2	M15V *15V OUTPUT	
5/3	AGND	
6/1	*24V INPUT DC/DC CONV	
6/2	*24V INPUT DC/DC CONV	
6/3	AUX ANALOG INPUT	
6/4	AUX ANALOG INPUT RTN	
7/1	CW LIMIT	
7/2	CCW LIMIT	
3/1	FAULT RELAY CONTACTS	
3/2	FAULT RELAY CONTACTS	
3/3	DRIVE DISABLE	
4/1	DGND	
4/2	INHIBIT TEST INPUT	
4/3	INHIBIT TEST INPUT	
16/1	TT WARNING	
16/2	EO	
16/3	E1	
16/4	F2	

BACKPLANE CONNECTOR/PINS	FUNCTION
10/1	P15V *15V OUTPUT
10/2	C HANDWHEEL INPUT
10/3	C HANDWHEEL INPUT
10/4	B HANDWHEEL INPUT
11/1	B HANDWHEEL INPUT
11/2	A HANDWHEEL INPUT
11/3	A HANDWHEEL INPUT
12/1	AUX INPUT 1
12/2	AUX INPUT 2
12/3	AUX INPUT 3
15/1	MAX
15/2	MAX
15/3	MAX
7/3	HOME FLAG
7/4	USER FLAG
7/5	IN POS
7/6	BUFFER FULL
7/7	SYNC
7/8	INIT
7/9	DGND
11/4	DGND OUTPUT OPTION
7/10	NAME
9/2	RTS
9/3	CTS
8/3	FXD
9/1	TXD
8/1	RTS
8/2	BTXD

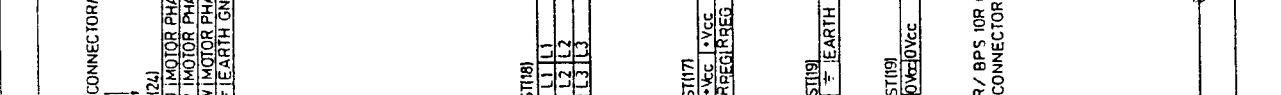
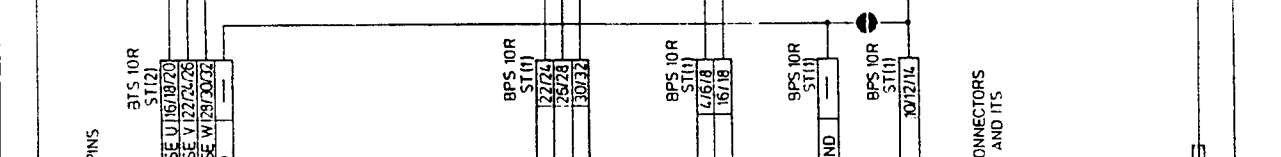
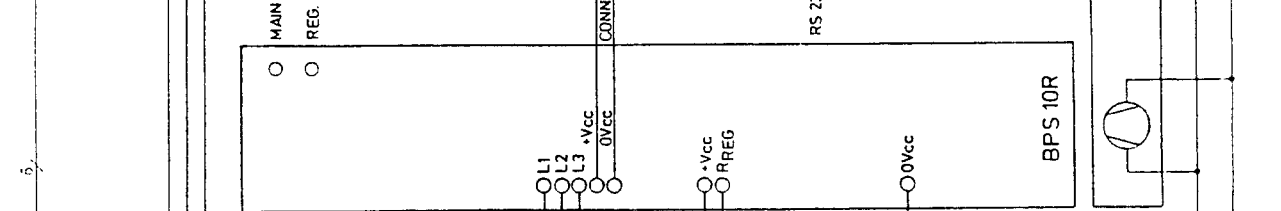

ALL FUNCTIONS REFER TO BTS 10R/ BPS 10R CONNECTORS AND ITS PINS. AND BACKPLANE CONNECTORS AND ITS PINS.

FAN SUPPLY VOLTAGE
 220V-50Hz¹¹

11 110V-/50Hz OPTIONAL (E011)

14387G

COMPONENT SIDE VIEW

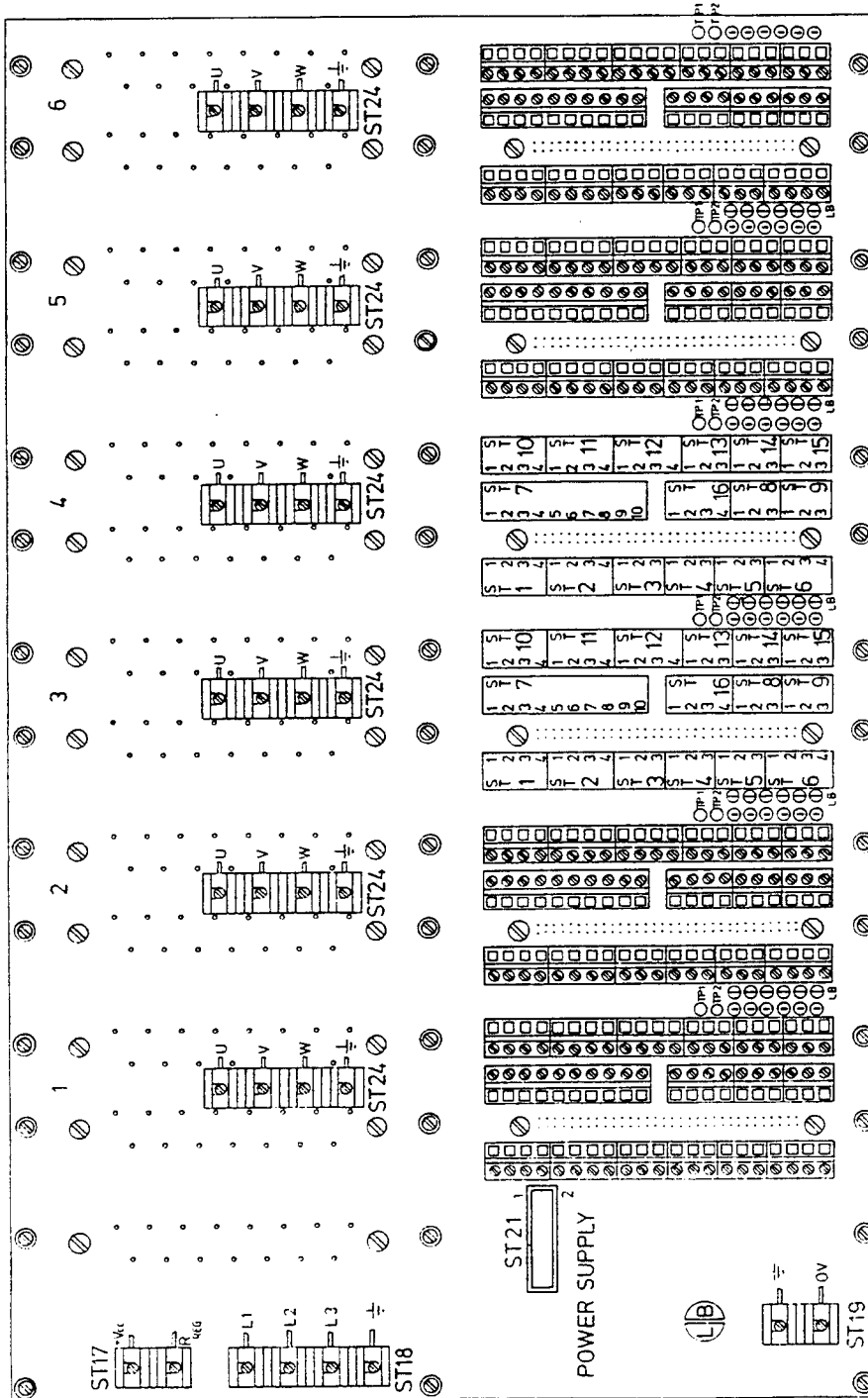

NOTE:-

- 1. HOLES MARKED THIS: - O ARE SOLDER STUDS.
- 2. BOTH X SECTIONS ARE ASSEMBLED AS PER Y SECTION.

PART NUMBER		DATE		REV	
14387G		11		1	
THIS IS A DRAWING OF A COMPLETE RACK BACK PLANE (COMPLETE) ASSEMBLY DRAWING (COMP SIDE)					
DATE	BY	CHKD	APP'D	REV	DESCRIPTION
14387G BAIRDOR <small>BAIRDOR ELECTRONICS</small>					

Set up procedure for S-BTS 10 R

1. E-Points

Check all jumpers for correct installation according to following listing:

E Point	Physical Layout	Description	Default
E1	* * * 1 2 3	Jumper pin 1-2 for S-BTS series Amplifiers	1-2 installed
E2	* * 1 2		Not installed
E3	* * 1 2	JUMP Pin 1 to Pin 2 to obtain normal X encoder operation. Remove Jumper for digital tach (1/T) X encoder operation.	1-2 installed
E4	1 2 3 * * *	JUMP Pin 2 to Pin 3 to allow phasing without hall effects. JUMP Pin 1 to 2 to phase with hall effects.	2-3 installed
E5	1 2 3 * * *	JUMP Pin 1 to Pin 2 to allow AMPENA/signal (low true) JUMP Pin 2 to Pin 3 to allow AMPENA/signal (high true)	1-2 installed
E6	1 2 * *	JUMP Pin 1 to Pin 2. With jumper installed, EA/ (Pin 51) of CPU is grounded, which causes the CPU to use external memory. Otherwise, EA/ (Pin 51) is pulled up to +5 volts, CPU then uses internal memory only.	Not installed
E7	1 * 2 *	JUMP Pin 1 to Pin 2 for Sync/Out (use on A0 card only). Note that if E7-1,2 is installed. E18-1,2 must be removed.	1-2 installed
E8	1 2 * *	HARD RESET	Not installed

Set up procedure for S-BTS 10 R (Continued)

E Point	Physical Layout	Description	Default
E9	* * * 1 2 3	JUMP Pin 2 to Pin 3 to obtain non-differential X encoder input mode, this will bias X encoder negative inputs to $1/2 V_{cc} = 2,5 V$.	1-2 installed
E10	1 2 3 * * *	Resolver install pin 2-3 Encoder install pin 1-2	2-3 installed
E11	1 2 3 * * *	Resolver install pin 2-3 Encoder install pin 1-2	2-3 installed
E12	* * * 1 2 3	Resolver install pin 2-3 Encoder install pin 1-2	2-3 installed
E13	--<>--	SYN \bar{U}	Not installed (Solder Pad)
E14	--<>--	SYN \bar{V} Hall inputs (optional)	Not installed (Solder Pad)
E15	--<>--	SYN \bar{W}	Not installed (Solder Pad)
E16	--<>--	Shield	Installed (Solder Pad)
E17	--<>--	Not used	
E18	2 * 1 *	JUMP Pin 1 to Pin 2 for input Sync. (use on all cards other than A0). Also see E7.	Not installed

Note: All S-BTS 10 R leave ex-works Munich with default settings.

S-BTS 10 R

μSMCC Component Layout

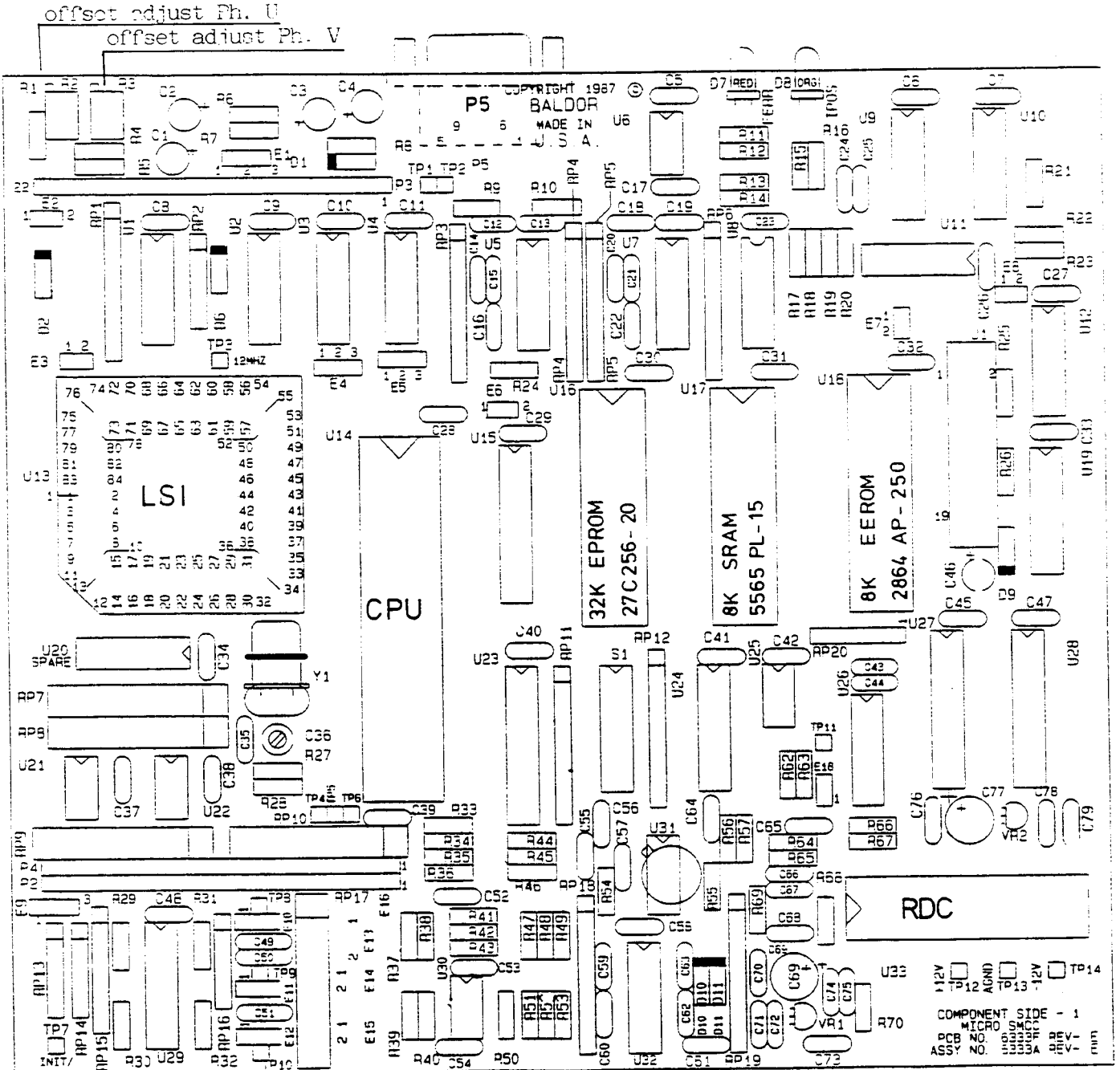

16099 A

Set up procedure for S-BTS 10 R (Continued)

2. Card address and Baud rate setting

Each card's address can be set-up by setting the DIP switch on the card as follows:

SW 1	SW 2	SW 3	SW 4	card address
0	0	0	0	0 (standard)
1	0	0	0	1
0	1	0	0	2
1	1	0	0	3

0	0	1	0	4
1	0	1	0	5
0	1	1	0	6
1	1	1	0	7

0	0	0	1	8
1	0	0	1	9
0	1	0	1	10 (a)
1	1	0	1	11 (b)

0	0	1	1	12 (c)
1	0	1	1	13 (d)
0	1	1	1	14 (e)
1	1	1	1	15 (f)

Communication with host computer

The DIP switch is used to select the communication mode and baud rate as follows:

SW 6	SW7	SW8	
0	0	0	9600 Baud (Standard)
1	0	0	4800 "
0	1	0	2400 "
1	1	0	1200 "
0	0	1	---- n/a (disables RS232)
1	0	1	300 Baud
0	1	1	38400 "
1	1	1	19200 "

SW5 of the DIP switch is used to Enable =0 or Disable =1 saving programs and parameters into EAROM memory. Regardless of the switch position, the contents of the EAROM are always uploaded upon power turn on or reset.

When the DIP switch settings are changed, it is necessary to reset the SMCC or cycle power, in order to activate the new set-up.

Set up procedure for S-BTS 10 R (Continued)

3. RS232 interface to host PC

Check wiring from PC to μ SMCC (P5) as shown below:

(PC) DB9 (DB 25)		P5 (S-BTS 10 R) DB9	
5	(7)	GND	5
8	(5)	CTS	8
7	(4)	RTS	7
2	(3)	RXD/	2
3	(2)	TXD/	3
4	(20)	DTR	4
6	(6)	DSR	6

Wire-link on μ SMCC
(not supported)

General rules on communication distance are:

38400 Baud	1 m.
19200 Baud	2 m.
9600 Baud	4 m.
!	!
!	!
!	!

Double the distance each time Baud Rate is reduced by half.

Shielding the longer RS232 cables is highly recommended. It is also advised, not to run the RS232 cable next to high power or A.C. signals such as the Servo Amplifier, line voltage etc.

4. Multi Axis S-BTS 10 R

If more than one S-BTS 10 R is fitted in the same rack follow the procedure:

- Set proper Card Address on the DIP-Switch. Normally starting with A0 on the left and continuing to Ax to the right.
- Install jumper E7 and leave jumper E18 out on A0.
- Leave E7 out and install E18 on all other cards.
- Close the 6 solderbridges on the backpanel for daisy chaining (next to ST13/14/15).
- Connect SYNC/-ST7/7 and INIT/-ST7/8 from one axis to the other.

Set up procedure for S-BTS 10 R (Continued)

5. With all preliminary installation and wiring finished according to drawing no: 15704 (page: 5) AC-power can be applied to the transformer primary.

The S-BTS 10 R should not be plugged into the rack yet.

Apply the proper AC-voltage and note the following:

- The cooling fan if present should operate.
- The DC-voltage should be measured at the terminals + V_{cc} and 0V: $200 V_{nominal}/240 V_{max}$.

Disconnect AC-power and wait several minutes to allow a discharge of the power supply capacitors.

Plug the S-BTS 10 R into the rack.

Before applying power remove motor connector or Disable Amplifier by leaving ST 3/3 open, leave resolver connector connected.

6. Apply power to the system and note the following:

After automatic power-up reset the Protection Enable LED and In Position LED illuminate green.

Now connect your PC to the S-BTS 10 R and load terminal program SMCC V3.X from the floppy disc.

The program will come up with communication information: 9600 Baud, COM 1, X1 Clock.

Enter "no" and card polling will start.

The next response should be the number of cards found.

Now step through all cards and verify the i-parameters using the F1 key.

Especially check parameter i39 and i40 to be set correctly:

i39 = 3	<u>Option:</u>
i40 = 4096 for 2 pole motor (BSM 2 R)	B01
i40 = 2048 for 4 pole motor (BSM 1 R, 3 R, 4 R)	B02
i40 = 1024 for 8 pole motor (BSM 4 F, 6 F, 8 F)	B04
i40 = 4096, i50 = 1 for 6 pole motor (BSM 6 R)	B03
<with parabolic only>	

Remark: Default parameters are available on floppy disk from V 3.4 on.

Filename Standard: ipblstan
Filename Parabolic: ipblparb.

Set up procedure for S-BTS 10 R (Continued)

6. i-Parameter Standard

DEFAULT (NON-PARABOLIC) ONE AXIS D.C. BRUSHLESS MOTOR PARAMETERS

i00	Following Error Limit	0	
i01	In-Position Band	100	
i02	Manual Data Input	0	
i03	Hand Shake Enable	1	
i04	Home Feed Rate	100	
i05	Servo Time	487	
i06	Reference Feed Rate	100000	
i07	Time Scale	65498	
i08	Accel/Decel Time	100	
i09	Pos. Integration Mode	1	
i10	Following Error Limit	1000	
i11	Feed Hold Slew Control	1	
i12	Select 24/6 kHz PWM Frequency	0	
i13	Brushless Motor	1	
i14	Processor A/D Converter Mode	0	
i15	Select Lookup Table	0	
i16	Handwheel Mode 1 Control	0	
i17	Velocity Display Time Base	7324	
i18	Display Formats	3	
i19	n/a	-	
i20	Proportional Gain Constant X	50	
i21	Differential Gain Constant X	240	
i22	Differential Gain Time Base X	0	
i23	Integral Gain Constant X	10	
i24	Home Direction X	0	
i25	Home Offset X	0	
i26	Home Flag Control X	5	
i27	Handwheel Scale Factor X	4096	
i28	Handwheel Mode Control 2 X	7	
i29	Handwheel Encoder Control X	3	
i30	Proportional Gain Multiplier X	1	
i31	Jog Feed Rate X	128	
i32	Normal PWM Limit Control X	255	
i33	Protective PWM Limit Control X	128	*1)
i34	Set Backlash X	0	
i35	Software Positive Pos. Limit X	-1	
i36	Software Negative Pos. Limit X	-1	
i37	Position Range X	0	
i38	Pos. Display Scale & Format X	1:1.0	
i39	Encoder Control X	3	*2)
i40	Encoder Counts per Rev.	2048	(4 pole)
i41	Phase Advance Scale Factor	64	
i42	n/a	0	
i43	Lookup Table Address	130	
i44	Select 3/4 Phase	1	
i45	Phase Offset	0	
i46	n/a	0	
i47	n/a	768	
i48	Star-Delta Connection	7	
i49	n/a	3	
i50	Resolver Phasing Enable	0	
i51	n/a	0	

Set up procedure for S-BTS 10 R (Continued)

6. i-Parameter Standard (Continued)

i52 Phase Finding Time	40
i53 Phasing PWM Value	20
i54 Resolver Base Address	65464
i55 n/a	-1
i56 n/a	-1
i57 n/a	0
i58 n/a	1:1.0
i59 n/a	3
i60 PLC Enable	0

Note: *1) not applicable
*2) no other values allowed
(standard only)

Set up procedure for S-BTS 10 R (Continued)

6. i-Parameter Standard (Continued)

DEFAULT PARABOLIC ONE AXIS D.C. BRUSHLESS MOTOR PARAMETERS

	i00	Following Error Limit	0	
	i01	In-Position Band	100	
	i02	Manual Data Input	0	
PARB	i03	Hand Shake Enable	1	
	i04	Home Feed Rate	100	
	i05	Servo Time	487	
	i06	Reference Feed Rate	100000	
	i07	Time Scale	65498	
PARB	i08	Accel/Decel Time	100	
	i09	Pos. Integration Mode	1	
	i10	Following Error Limit	1000	
	i11	Feed Hold Slew Control	1	
PARB	i12	Move Delay Time	40	*1)
	i13	Brushless Motor Enable	1	
	i14	Processor A/D Converter Mode	0	
	i15	Select Lookup Table	0	
PARB	i16	Handwheel Mode 1 Control	0	
	i17	Velocity Display Time Base	14648	
	i18	Display Formats	3	
PARB	i19	Address of Last Card	0	
	i20	Proportional Gain Constant	1000	
	i21	Differential Gain Constant	10	
PARB	i22	Velocity Feedforward Gain	10	
	i23	Integral Gain Constant	0	
	i24	Home Direction	0	
	i25	Home Offset	0	
	i26	Home Flag Control	5	
PARB	i27	Handwheel Scale Factor	4096	
	i28	Handwheel Mode Control 2	3	
	i29	Handwheel Encoder Control	3	
PARB	i30	Acceleration Feedforward Gain	0	
	i31	Jog Feed Rate	128	
	i32	PWM Limit	255	
	i33	Protective PWM Limit	128	*2)
	i34	Set Backlash	0	
	i35	Software Positive Pos. Limit	-1	
	i36	Software Negative Pos. Limit	-1	
	i37	Position Range	0	
	i38	Pos. Display Scale & Format	1:1.0	
	i39	Encoder Control	3	
	i40	Encoder Counts per Rev.	2048 (4 pole)	
	i41	Phase Advance Scale Factor	12	
	i42	n/a	0	
	i43	Lookup Table Address	130	
	i44	Select 3/4 Phase	1	
	i45	n/a	0	
	i46	n/a	0	
	i47	n/a	4096	
	i48	Star-Delta Connection	0	
	i49	n/a	3	
	i50	n/a	0(1 for 6 pole)	
	i51	n/a	200	

Set up procedure for S-BTS 10 R (Continued)

6. i-Parameter Standard (Continued)

	i52 Phase Finding Time	40	
	i53 Phasing PWM Value	10	
PARB	i54 Phase Offset	0	
	i55 n/a	-1	
	i56 n/a	-1	
	i57 n/a	0	
	i58 n/a	1:1.0	
	i59 n/a	3	
PARB	i60 Deadband X	0	
PARB	i61 Deadband Y	0	*2)
PARB	i62 PLC Enable	0	
PARB	i63 Parabolic Mode Control	0	
PARB	i64 X Encoder/Resolver Base Add.	65464	
PARB	i65 Y Encoder/Resolver Base Add.	0	*2)
PARB	i66 Speed of Second X Resolver	0	
PARB	i67 Speed of Second Y Resolver	0	*2)
PARB	i68 Second X Resolver Base Address	0	
PARB	i69 Second Y Resolver Base Address	0	*2)
PARB	i70 X Encoder/Resolver Bias	0	
PARB	i71 Y Encoder/Resolver Bias	0	*2)
PARB	i72 X Encoder/Resolver Size	0	*2)
PARB	i73 Y Encoder/Resolver Size	0	*2)
PARB	i74 Second X Resolver Size	0	
PARB	i75 Second Y Resolver Size	0	*2)
PARB	i76 X Enc. Data/Strobe Logic Level	1	
PARB	i77 Y Enc. Data/Strobe Logic Level	0	*2)
PARB	i78 X Range Mode Control	0	
PARB	i79 Y Range Mode Control	0	*2)

Note: *1) i12 ≥ 100 for BSM 6 R

*2) not applicable

7. Switch power off and wait several minutes to allow discharge. Then connect motorconnector to the motor and take ST 3/3 "high" and ST 7/1, ST 7/2 "low".

Caution: During initial set-up the motor(s) must be disconnected from the machine to allow proper phasing and to prevent damage (also see User Note 1 on page 38).

Re-apply AC-power and note the following: After automatic power-on-reset the motor will make a jump left and right and then be stable.

When turning the motorshaft torque will be developed. The standard gain parameters should ensure stable but not perfect operation. Especially for small motors (BSM 1/2/3) the proportional gain (i20) may be too high causing oscillation. In these cases the value of i20 must be decreased by 50 %. Fine tuning of the different gains should be done later.

Caution: Do not try to power-up with the Total Disable Input activated. The motor cannot do it's phasing, after enabling, the motor will speed-up and the amplifier will go into current saturation.

Set up procedure for S-BTS 10 R (Continued)

8.1 Preventing start-up-phasing jump (with standard CPU)

The S-BTS 10 R is designed to function with resolvers or encoders and to perform automatic phase finding. The phase finding procedure requires that the motor shaft moves a maximum of one half electrical motor revolution (90 degrees for a 4 pole motor) in order to precisely locate correct motor phasing. Even though the phase finding time and torque level are both definable, it is sometimes undesirable to have a "phase finding" cycle on a machine, especially since full torque cannot be guaranteed during phasing and motion occurs bidirectionally.

The procedure to follow for eliminating the initial phasing search when using the resolver is:

- a) Be sure that i54 is set correctly: i54 is ffb8 or 65464

This parameter assigns the memory address at which the resolver is located.

Also check i50 and i45 to be 0.

Caution: If i50/i45 \neq 0, disable amplifier first by taking ST 3/3 low, then change to 0 and enter "s" for save.

- b) First do a "HOME" and reset the μ SMCC with "\$\$" or equivalent. S-BTS 10 R will now perform it's normal power on phasing procedure.
- c) When phasing is completed, again do a "HOME" by entering "h" with i25 (Home offset parameter) set to 0 (zero offset). This causes the resolver to be at zero position.
- d) Now read the value of memory location fe24 by issuing an "r" command for two bytes:

rfe24,2

The SMCC will send back 2 hexadecimal bytes (low byte first) as the answer which represents the present phasing position offset. Note that it is important to have done a home with zero offset before this procedure because otherwise the value of the resolver position has to be subtracted from the value of fe24.

- e) Next, convert the value of fe24 from hexadecimal to decimal and enter this value into i45, phase offset.

Example: SMCC responds with de04.

Swap low and high byte to 04de.

Convert 04de to its decimal value:

$$0 \times 16^3 + 4 \times 16^2 + 13 \times 16^1 + 14 \times 16^0 = 1246$$

Set up procedure for S-BTS 10 R (Continued)

- f) Finally, change the value of i50 from "0" to "1" which tells the μ SMCC to skip doing a phasing search and to use the value stored in i45 as the phase offset. Finish by entering a "save" command: "s". The user may adjust the value of i45 in order to optimize the phase offset. It is also possible to change the phasing angle as a function of velocity by using i41 to generate a phase shift proportional to velocity. Please refer to the User Notes in the last section of this manual.

8.2 Preventing start-up phasing jump (with parabolic CPU)

The S-BTS 10 R is designed to function with resolvers or encoders and to perform automatic phase finding. The phase finding procedure requires that the motor shaft moves a maximum of one half electrical motor revolution (90 degrees for a 4 pole motor) in order to precisely locate correct motor phasing. Even though the phase finding time and torque level are both definable, it is sometimes undesirable to have a "phase finding" cycle on a machine, especially since full torque cannot be guaranteed during phasing and motion occurs bidirectionally.

The procedure to follow for eliminating the initial phasing search when using a resolver is:

- a) Be sure that i64 is set correctly: i64 is ffb8 or 65464

This parameter assigns the memory address at which the resolver is located.

Also check i54 = 0 and i72 = 0

Caution: If i54/i72 \neq 0, disable amplifier first by taking ST 3/3 low, then change to 0 and enter "s" for save.

- b) Do a "HOME" by entering "h" and reset μ SMCC with "\$\$" or equivalent. S-BTS 10 R will now perform it's normal power on phasing procedure.
- c) When phasing is completed, again do a "HOME" with i25 (Home offset parameter) set to 0 (zero offset). This causes the resolver to be at zero position.
- d) Now read the value of Memory location fe26 by issuing an "r" command for two bytes:

rfe26,2

The SMCC will send back 2 hexadecimal bytes as the answer which represents the present phasing position offset. Note that it is important to have done a home with zero offset before this procedure because otherwise the value of the resolver position has to be subtracted from the value of fe26.

Set up procedure for S-BTS 10 R (Continued)

- e) Next, convert the value of fe26 from hexadecimal to decimal and enter this value into i54, phase offset.

Caution: Low byte first!

Swap bytes before convert to decimal.

- f) Finally, change the value of i72 from "0" to "3" which tells the SMCC to skip doing a phasing search and to use the value stored in i54 as the phase offset. Finish by entering a save command: "s". The user may adjust the value of i54 in order to optimize the phase offset. It is also possible to change the phasing angle as a function of velocity by using i41 to generate a phase shift proportional to velocity. Please refer to the last section of this manual (User Notes).

Please be aware that the motor lead phasing and the resolver phasing must be set correctly, otherwise the system will neither phase nor function correctly.

9. Now the S-BTS 10 R is ready to go. For demonstration and test purposes every S-BTS 10 R has a small program in EAROM.

This program can be run by entering "R" on your PC. The motor will move 100.000 counts, stop for 1 second and go back to zero again.

After 1 second delay this will be repeated for ever. The program can be stopped by entering "Q" (Quit).

If the program is not running the buffer may be cleared or the limit switches and/or Feed Hold may be activated.

The next step will be to optimize motor response on the machine by varying the gain parameters.

For the program instructions, please refer to the SMCC Manual.

10. Response Optimization

The step response can be optimized with the i-parameters i20 (proportional gain), i21 (differential gain) and for parabolic also i22 and i30.

In order to achieve proper adjustment it is necessary to observe the velocity waveform on TP 11 (μ SMCC) with an oscilloscope. The servo performance is adjusted properly when the velocity waveform shows a single overshoot on applying a step command. At constant velocity the AC-component on TP 11 should be kept as low as possible to avoid excessive motor heating.

The motor speed in rpm can easily be read from the terminal by entering "v".

With parabolic CPU the servo performance analysis can be done by using the Data Gatherer/Plotter feature. Please refer to SMCC manual.

S-BTS 10 R - Testpoints

On μ SMCC board (see page 10):

TP1: Phase U Current Command signal to current loop BTS 10.
10 V $\hat{=}$ peak current (rms)
Rout = 220 Ω

TP2: same as TP 1 for Phase V

TP3: 12 MHz clock
HCMOS output (74HC14)

TP4: SYN \bar{U}

TP5: SYN \bar{V} Hall Sensor Signals (optional)

TP6: SYN \bar{W}

TP7: Reset/ (INIT/)
Input from ST 7/8

TP8: Encodersimulation
Output from RDC CHA (channel "A")

TP9: same CHB

TP10: same CHC (Zero Marker)
CHA and CHB in quadrature

TP11: Velocity Testpoint 1,67 V/1000 rpm \pm 15 %,
 $V_{\text{OFFSET}} \leq \pm 0,25$ V

TP12: + 12 V

TP13: AGND

TP14: - 12 V

On S-BTS 10 R Control Card (see page 23):

TP1: Actual current phase U
 $I_{pk} \hat{=}$ 10 V

TP2: Actual current phase V

TP3: Actual current phase W

S-BTS 10 R - Testpoints (Continued)

Note: For torque calculations referring to the actual current the formula is:

$$T = 3 \cdot KT \cdot \frac{V_{TP} \cdot I_{PK}}{10}$$

where T = Motortorque (Nm)

KT = Torque constant per phase (Nm/A)

V_{TP} = Voltage on TP1, 2 or 3 (peak)

I_{PK} = peak rms current rating of amplifier S-BTS 10 R
($I_{PK} \hat{=} 2 \cdot x I_{NOM}$)

TP6: Analog input signal after potentiometer RP1.
For use of this input please refer to SMCC Software Manual,
also see parameter i14.

TP9: PWM signal 20 V_{PP} , 10,5 kHz triangle wave
(for test purposes only)

Testpoints on backpanel:

TP1: n/a

TP2: see TP3 on control card

S-BTS 10 R - I/O Hardware

Inputs (unless otherwise stated 5 V TTL)

CW Limit high or open inhibits the move	ST 7/1 (30a)
CCW Limit high or open inhibits the move	ST 7/2 (30b)
Home Flag/ User Flag/	ST 7/3 (11b) ST 7/4 (5a)
See Software Manual i 26	
Aux. Input 1 ($\overline{\text{MAI1}}$) Low is true	ST 14/1 (5b)
Aux. Input 2 ($\overline{\text{MAI2}}$) Low is true	ST 14/2 (6b)
Aux. Input 3 ($\overline{\text{MAI3}}$) Low is true	ST 14/3 (21a)
Home/ Low activates "Seek Home"	ST 7/10 (6a)
START/ Low is "Start"	ST 12/1 (14a)
STOP/ Low is "Stop"	ST 12/2 (14b)
STEP/ Low is "Step"	ST 12/3 (15a)
HOLD/ Low is "Hold"	ST 12/4 (15b)
JOG+/ Low is "Jog CW"	ST 13/1 (16a)
JOG-/ Low is "Jog CCW"	ST 13/2 (16b)
INIT/ Low is "Reset"	ST 7/8 (13b)
SYNC/ See E-Points E7/E18	ST 7/7 (13a)

Note: ST 7/7 must be linked for multi-axis see page 12 / 4e)

1) On μSMCC

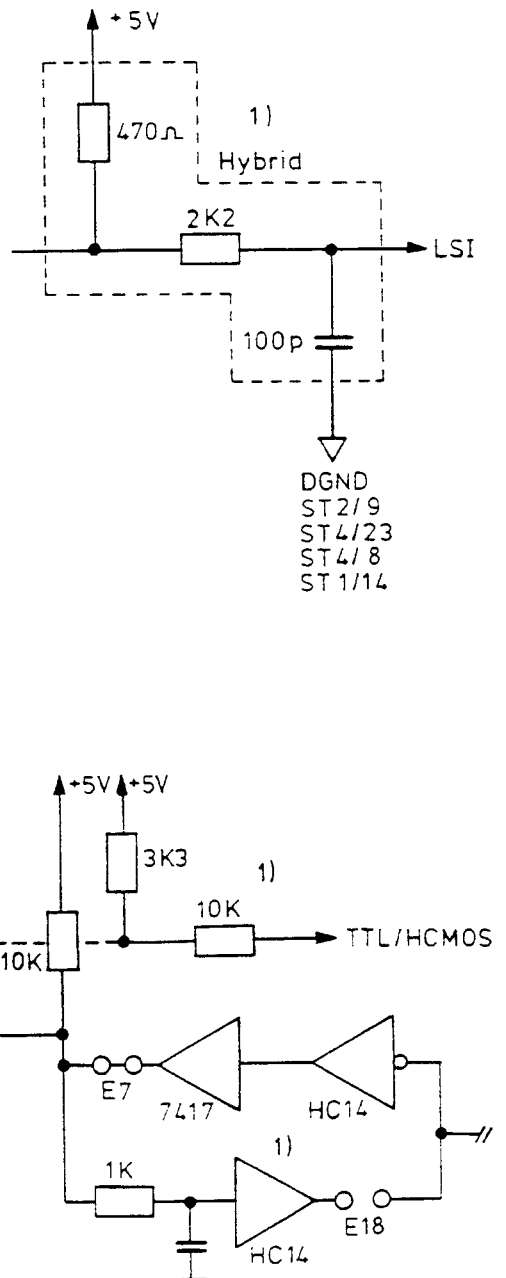

S-BTS 10 R - I/O Hardware (Continued)

Inputs (Continued)

Resolver

SIN-Input S4
(COS-Input S3)

ST 1/3 (2a)
ST 2/1 (3a)

SIN+Input S2
(COS+Input S1)

ST 1/4 (2b)
ST 2/2 (3b)

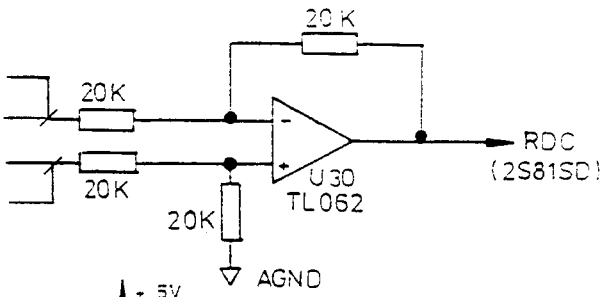

Signal waveform sinusoidal
7,2 kHz, 10 Vpp

Handwheel Input A/

" " B/
" " C/
" " A
" " B
" " C

ST 11/2 (10a)
ST 10/4 (9a)
ST 10/3 (8b)
ST 11/3 (10b)
ST 11/1 (9b)
ST 10/2 (8a)

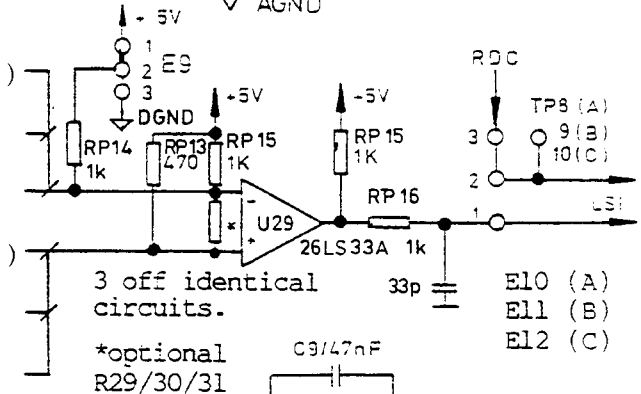

3 off identical circuits.

*optional R29/30/31

$V_{in} \text{ max.} = + 5 V_{DC}$

Auxiliary Analog Input

0 V. RTN ST 6/4 (31b)
INPUT ST 6/3 (31a)

0 ... + 10 V_{DC} max.

Resolution 8 Bit

Drive Disable
high = enable

$V_{in} \text{ max.} = + 5 \dots + 30 V_{DC}$

It Inhibit Test

Note: For test purposes only,
low disables electronic fusing

+ 24 V_{DC} Input for Control
logic supply (optional)

Input range + 18 ... 60 V_{DC}
Input Power 30 W

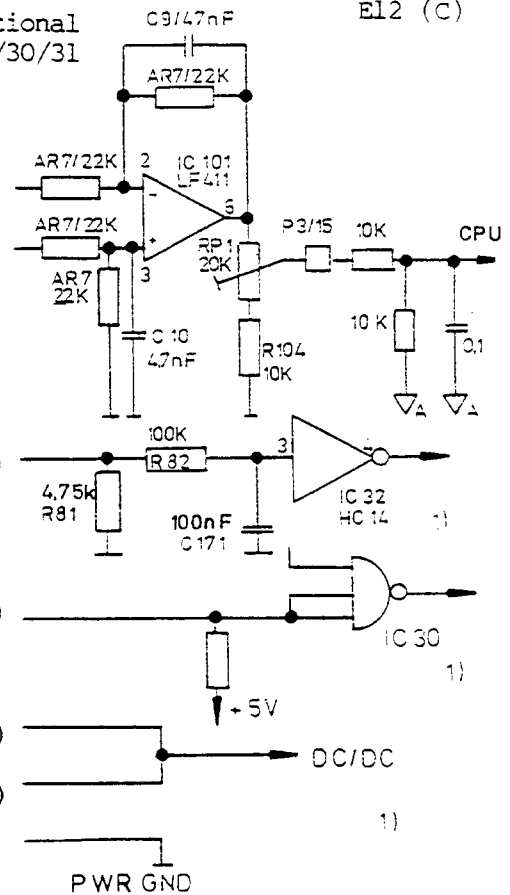

ST 3/3 (27a)

ST 4/3 (12b)

ST 6/1 (18a)

ST 6/2 (18b)

ST 19 (0 V)

PWR GND

1) On Control Card

S-BTS 10 R - I/O Hardware (Continued)

OUTPUTS

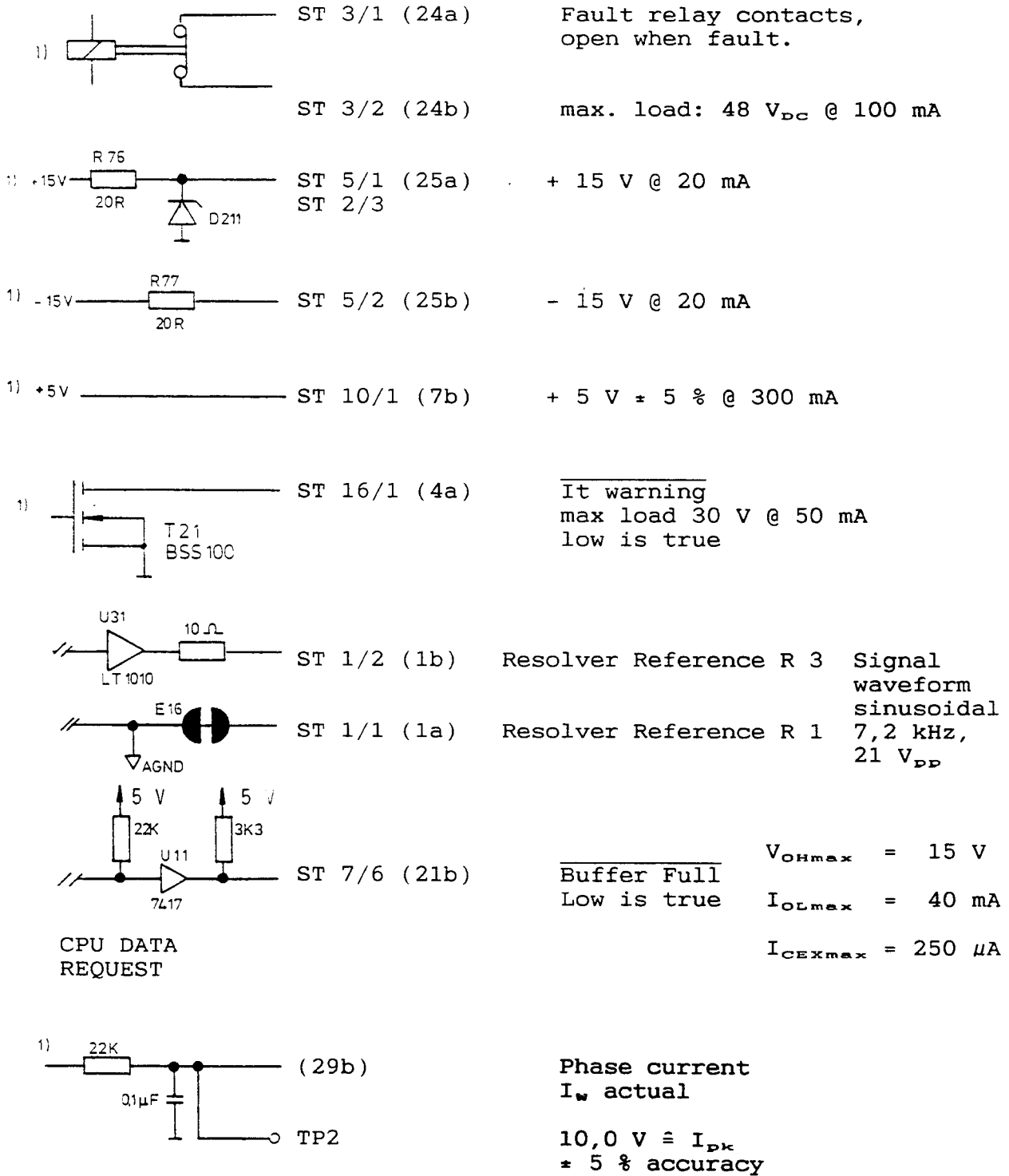

Note: TP 2 on backpanel

1) On Control Card

S-BTS 10 R - I/O Hardware (Continued)

OUTPUTS (Continued)

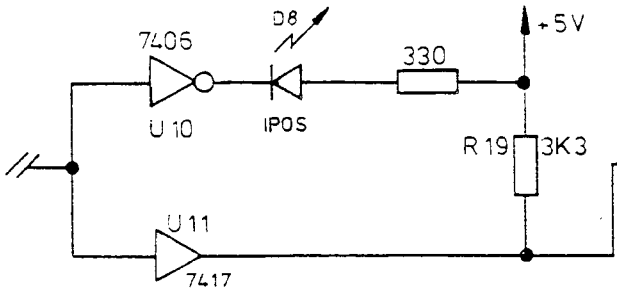

ST 7/5 (4b) IN POSITION
high is true

$V_{OHmax} = 15 V$
 $I_{OLmax} = 40 mA$
 $I_{CEXmax} = 250 \mu A$

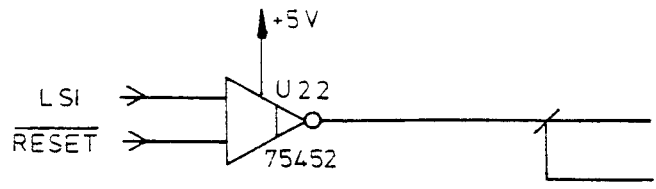

ST 15/1 (22a) $\overline{MAO2}$
ST 15/2 (22b) $\overline{MAO3}$

General purpose
(machine) outputs
low is true
Open Collector

$V_{CER} = 30 V max$
 $V_{CESAT} = 0,7 V max$
 $I_{OH} = 300 \mu A max$
 $I_{OL} = 300 mA max$

1)

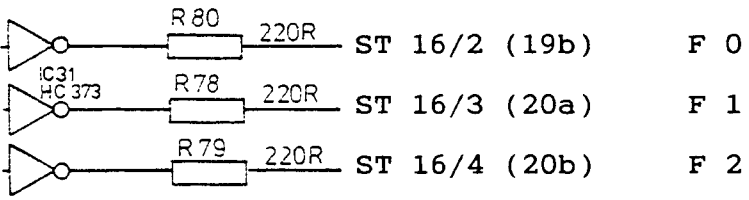

Error code
5 V Output

	F0	F1	F2	
	0	0	0	OK (BTS 10 is happy)
	0	0	1	Overtemperature
	0	1	0	Undervoltage
	0	1	1	Electronic Fusing
15 sec.	1	0	0	Overvoltage
	1	0	1	Resolverfault
	1	1	0	Overcurrent
	1	1	1	It warning, electronic fusing after 15 sec.

Note: It warning is not latched, all others are.

S-BTS 10 R - I/O Hardware (Continued)

RS232

Data format: 1 Start Bit
 8 Data Bits
 1 Stop Bit
 No Parity.

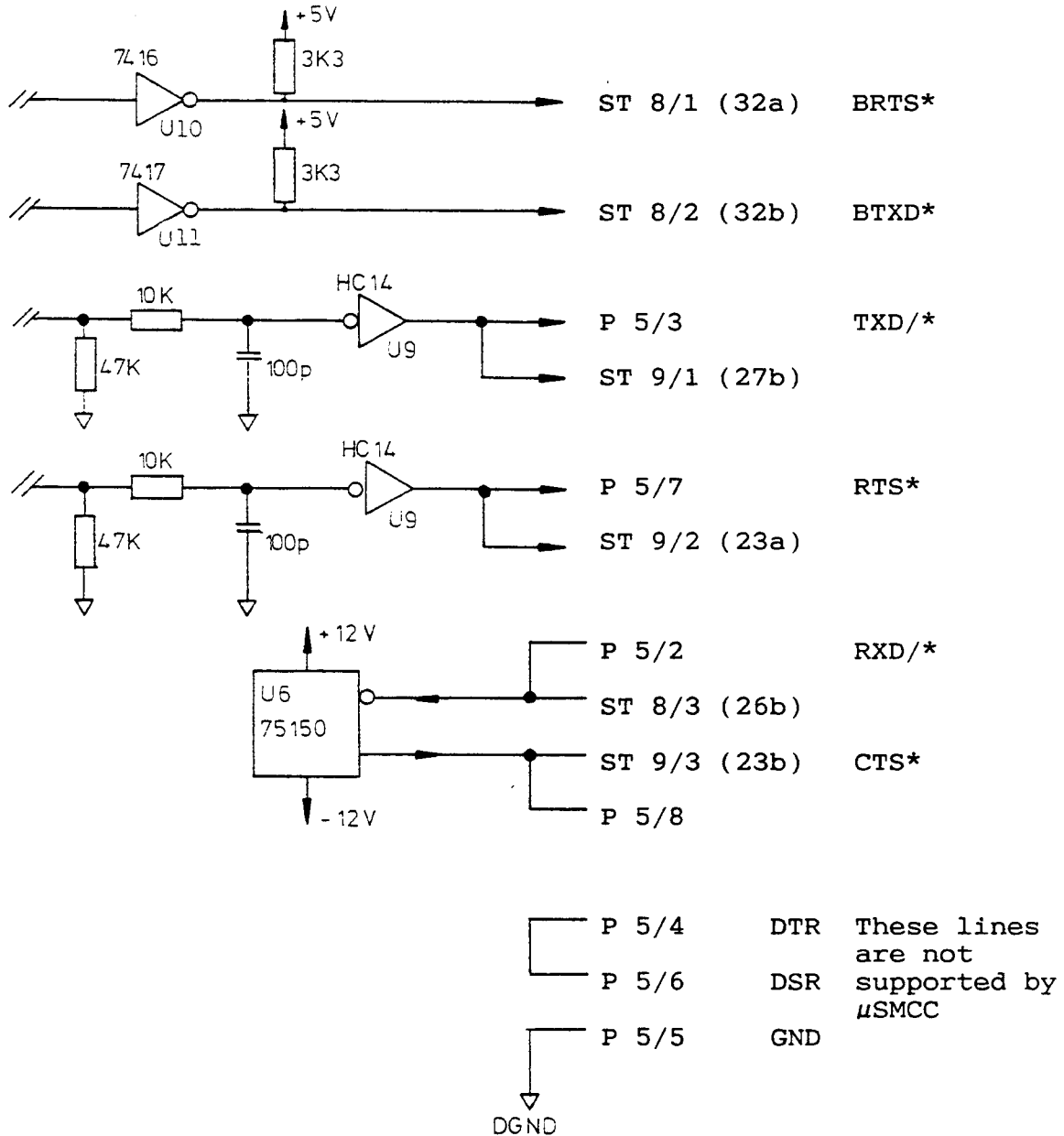

* Daisy Chained on Backpanel

J-Expansion Pin Assignment

(see layout J1 on page 10)

<u>PIN</u>	<u>FUNCTION</u>
1 O/P	- 15 V @ 10 mA
2 O/P	RESET
3 O/P	+ 15 V @ 10 mA
4 O/P	WR/
5	DGND
7	
16 I/O	AD 0
12 I/O	AD 1
8 I/O	AD 2
6 I/O	AD 3
10 I/O	AD 4
14 I/O	AD 5
18 I/O	AD 6
20 I/O	AD 7
9 O/P	+ 5 V @ 100 mA
11	
13 O/P	RD/
15 O/P	DSPCS/
17 O/P	ALE
19 O/P	MMCS

All Signals on TTL Level.



P5 SOLDER SIDE
FOR TR 44,50,51
CUT PINS 1MM
SHORTER

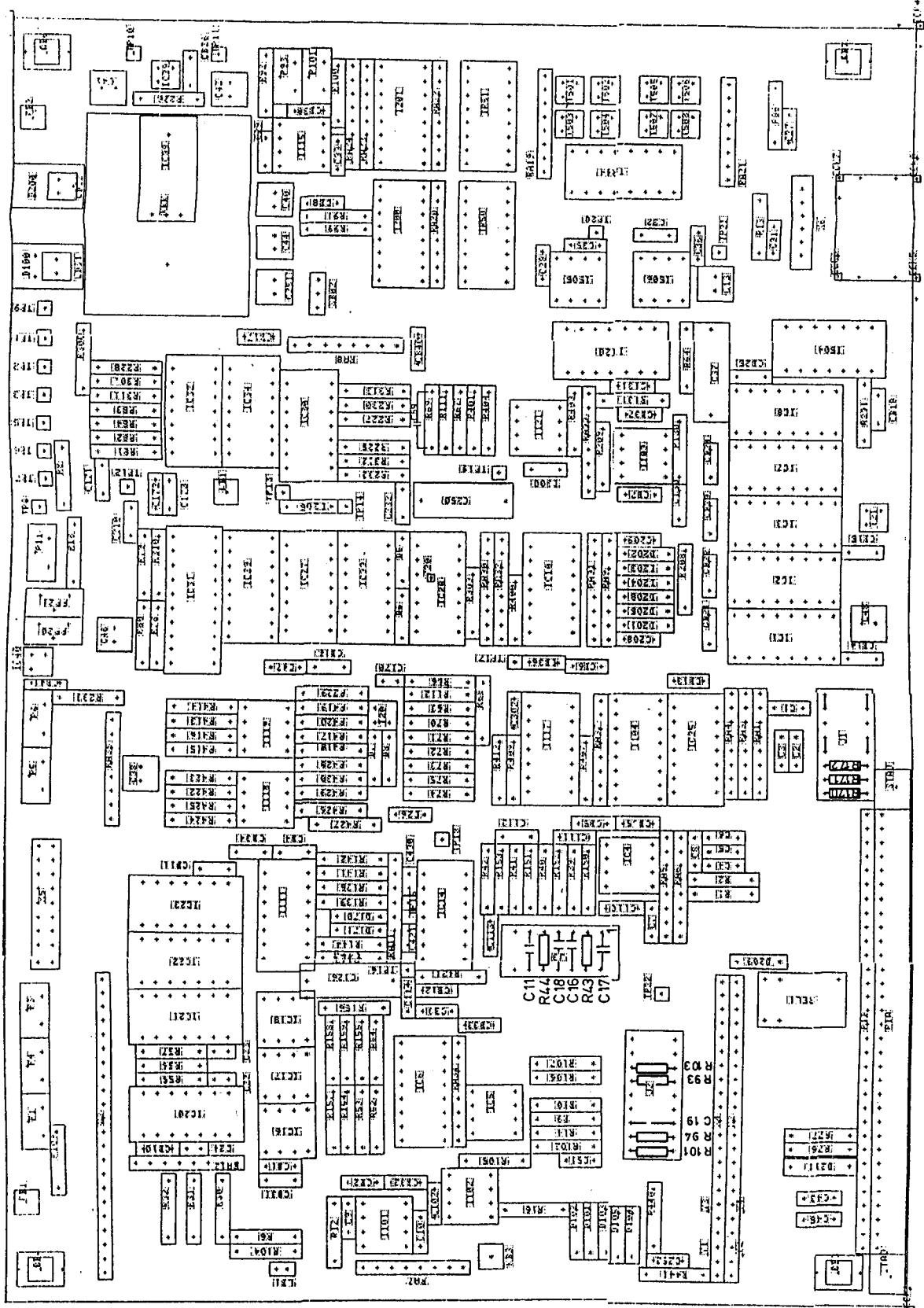

STAND: 175.88
5.7.88
29.9.88 MI

SURFACE ROUGHNESS		TOLERANCES		MATERIAL		PROTECTIVE FINISH	
TITLE BTS 10/1 CONTROL CARD COMPONENT LAYOUT				SCALE		DRAWING NO.	
13809 C							
PROPRIETARY NOTICE BALDOR The drawings, designs, specifications and data herein are the property of BALDOR ELECTRIC COMPANY. No part of this document may be reproduced or transmitted in any form or by any means, electronic, mechanical, photocopying, recording, or by any information storage and retrieval system, without the prior written permission of BALDOR ELECTRIC COMPANY.							
ISSUED	DATE	NAME	REV. NO.				
CHECK	22.04.	HARTMANN					
NORM							

BALDOR
ELECTRIC COMPANY

BPS 10-200-R

Power Supply for S-BTS 10 R Series Amplifiers

Together with an external 3-phase isolation-transformer the BPS 10 represents the 200 V DC-Power supply. It's function besides fullwave rectification and filtering also includes a power shunt or regeneration. The regeneration circuitry limits the DC-Bus voltage level during deceleration of the motor with it's load thus preventing an overvoltage shut down on the S-BTS 10 R.

On the frontplate there are two indicators: one for the 200 V DC-supply, the other for the activity of the regeneration.

Input for 200 V DC output: 3 x 140 V AC nominal

Regeneration level: 275 V DC (P1 set and sealed ex works)

Load Resistors:

For all BPS 10 versions an internal load resistor with 80 W continuous powerrating is included. The peak power dissipation should not exceed 4 kW for time intervals shorter than 1 sec.

For applications where higher powerratings are needed an external resistor may be connected to ST17 (+ V_{CC}/R_{REG}), in this case the internal resistor (R18) has to be removed.

External resistors are available with 320 W powerrating.
(16 kW @ ≤ 1 sec.)

Note: The switching current (20 A) may not be increased,
hence the resistor value must be $\geq 14 \Omega$.

DRAWING NUMBER
16180 B

REVISIONS	DATE	APPROVED
LTR		
DESCRIPTION		

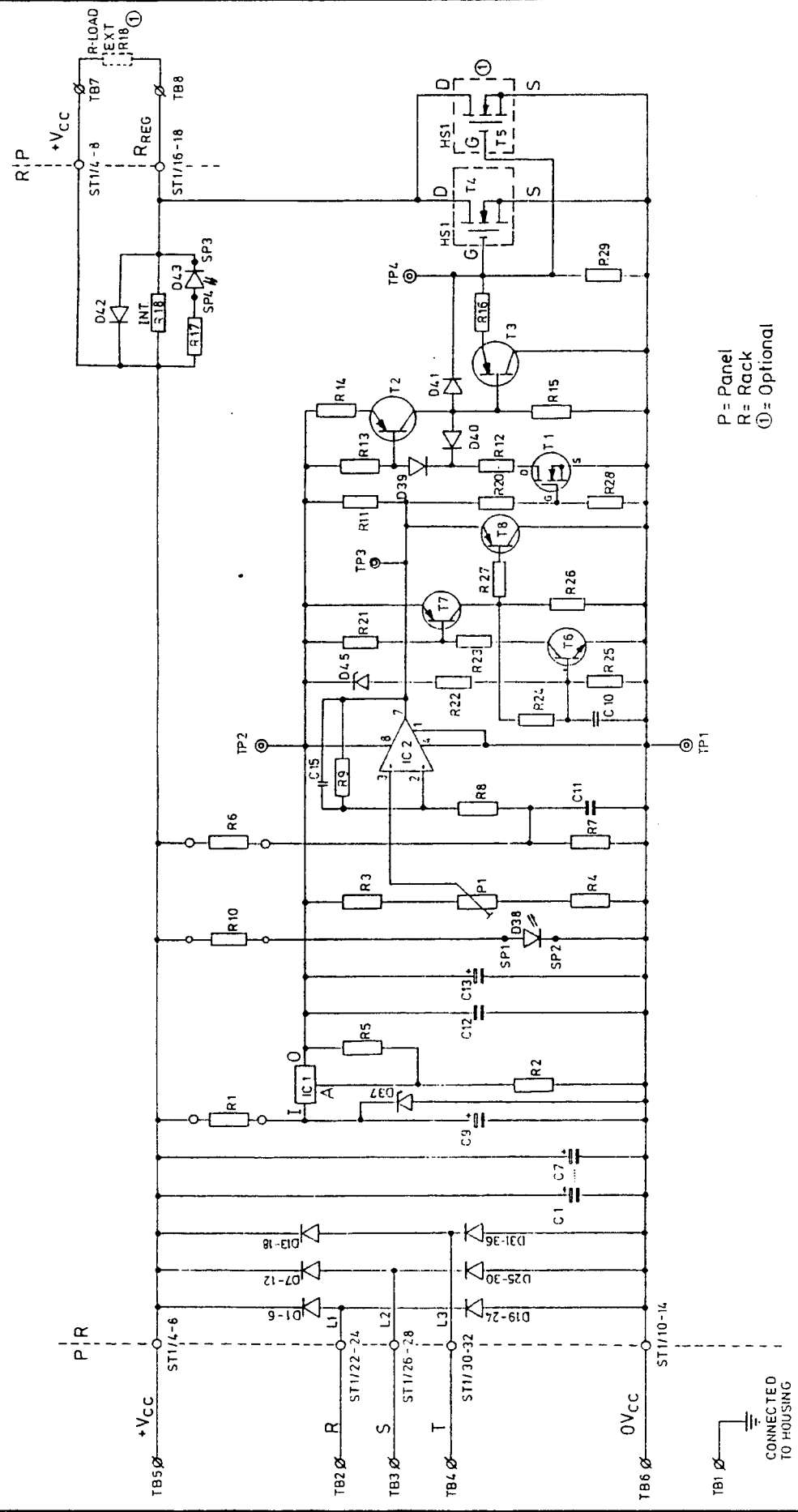

P = Panel
R = Rack
① = Optional

DATE	REVISED	BY	REASON
<p>ALR SERVOTRON Controls & Service: United States Ground Components: 4545 SERVOTRON, INC. 1455 S. Airport Avenue San Mateo, California 94401 Phone: (415) 352-1111 Telex: 232320 SRTS</p>			
TITLE		DRAWING NUMBER	
BPS 10R/P POWER SUPPLY CIRCUIT DIAGRAM		16180 B	
SCALE		REF DRAWING NO	
PROTECTIVE RANGE			
MATERIALS			
OCT 88			

PROPRIETARY NOTICE
 This document contains proprietary information belonging to ALR SERVOTRON, INC. It is the property of ALR SERVOTRON, INC. and is not to be distributed, copied, or reproduced in any form without the written consent of ALR SERVOTRON, INC. Any unauthorized use or disclosure of this information may result in legal action.

14400B

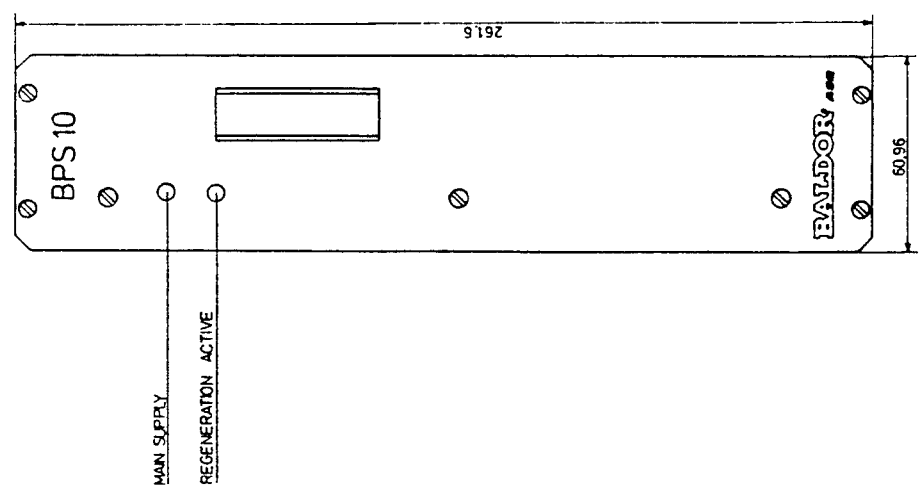
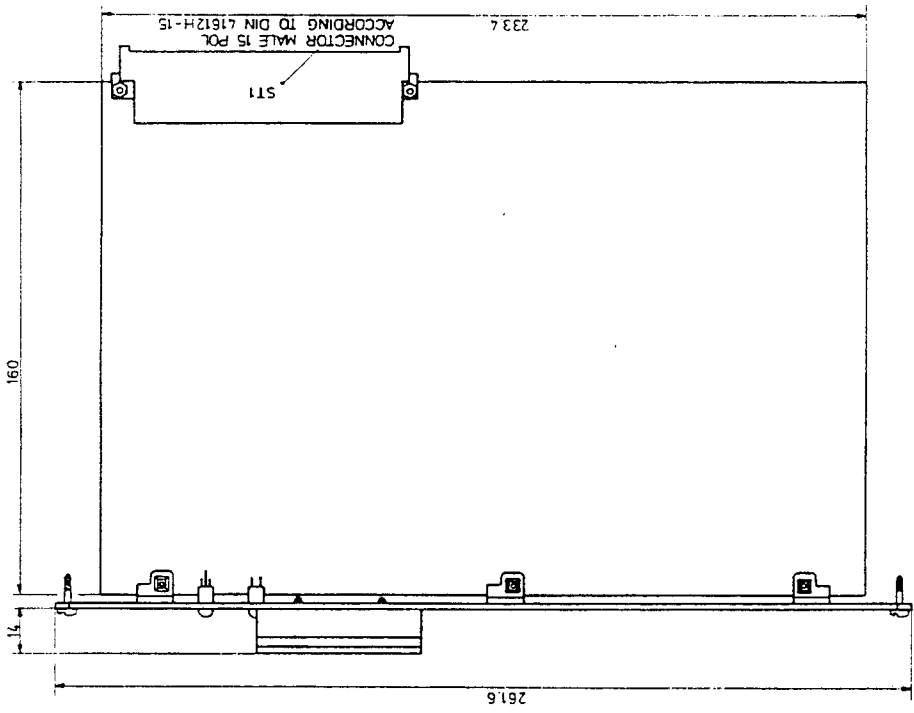

BPS 10
FRONT PANEL
MOUNTING DETAILS TO PCB

SCALE	1:1	FIGURE NO.	14400B
EVALDOR			
A.S.R. SERVOTRON			

14476G

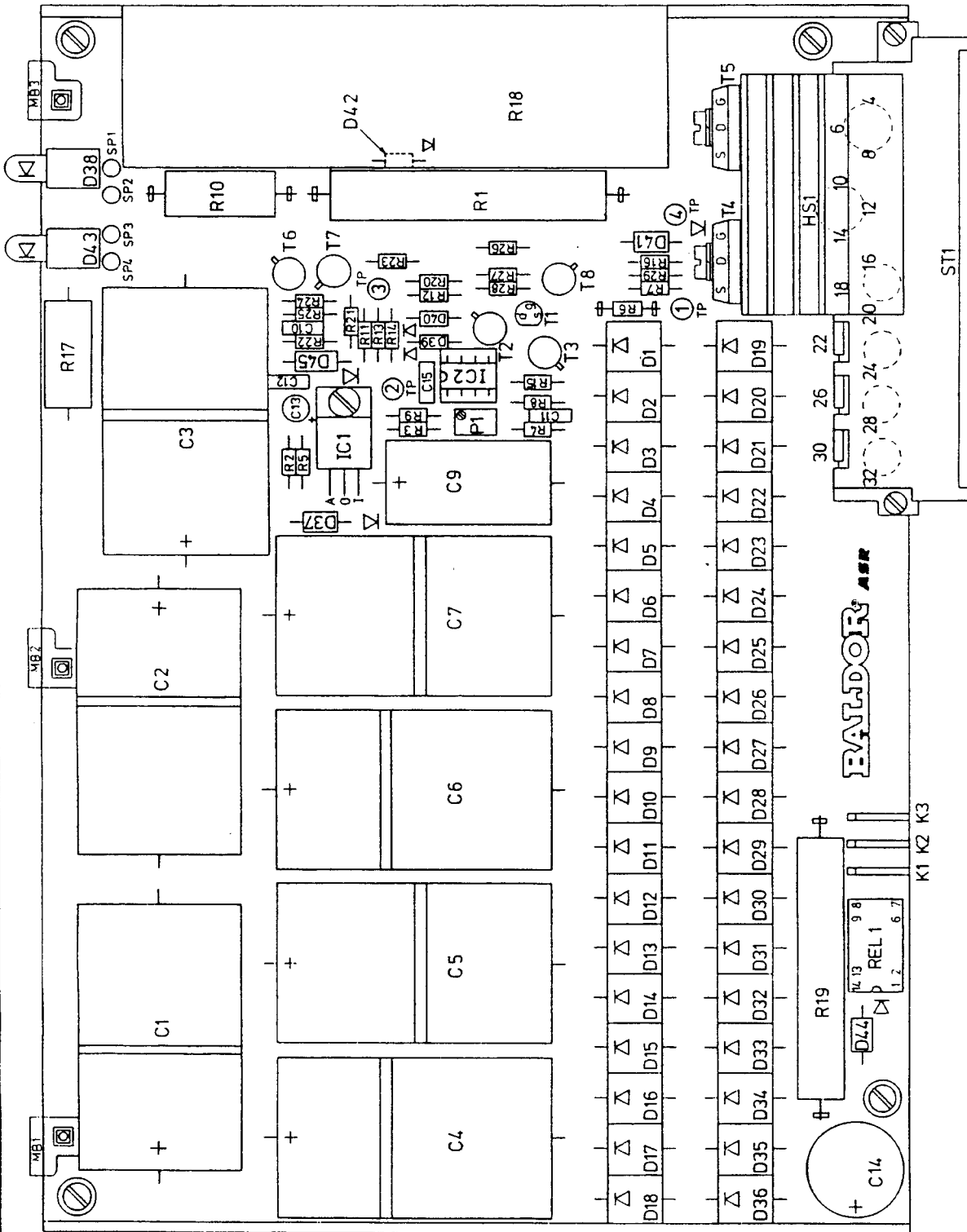

NOTE

1. H51 IS MOUNTED ON SPACERS
2. COMPONENTS SHOWN THUS  ARE MOUNTED ON SOLDER STUDS
3. ON BPS 10P D38/43 ARE MOUNTED ON A SEPERATE PCB ATTACHED TO THE HOUSING FRONT WALLS THEN WIRED BACK TO THERE RESPECTIVE SOLDER POINT ON THE POWER SUPPLY BOARD

PART NUMBER		REV. NO.		DATE	
14476G		2.1		14476G	
BALDOR					
A.S.R. SERVOTRON					

BPS 10 10P 10R
 POWER SUPPLY
 COMPONENT OVERLAY
 BALDOR ELECTRIC CO.
 14476G

S-BTS 10 R-Protection Chokes

The following chokes are available to protect the amplifier against shorts between the outputs and to ground. One choke in each of the three phases to the motor is needed for full protection.

L 100-6
15528A#
1 mH/6 A

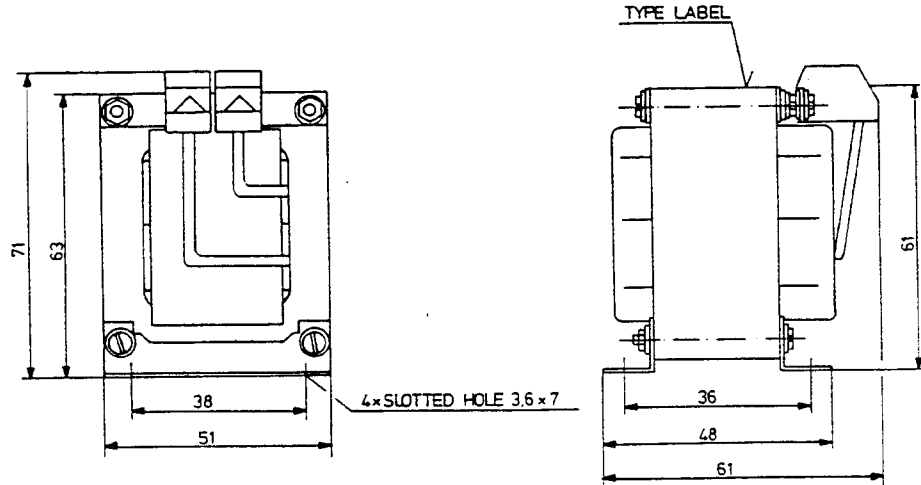

L 040-15
12956A
400 μ H/15 A

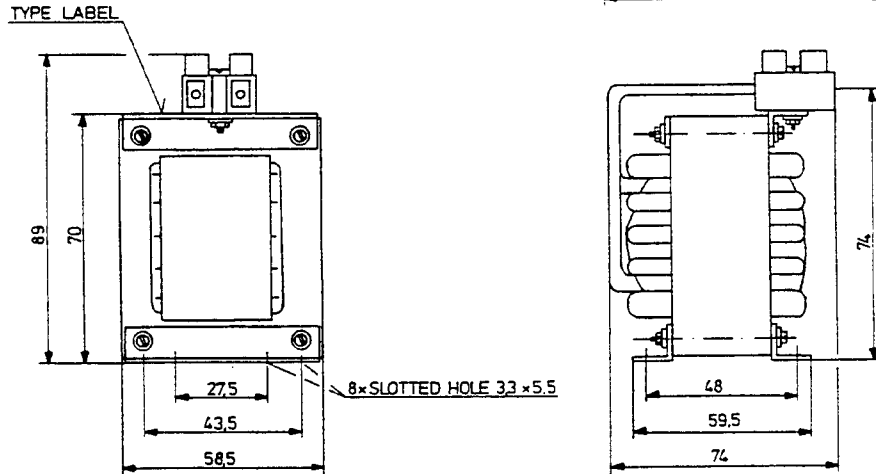

L 040-20
15527A
400 μ H/20 A

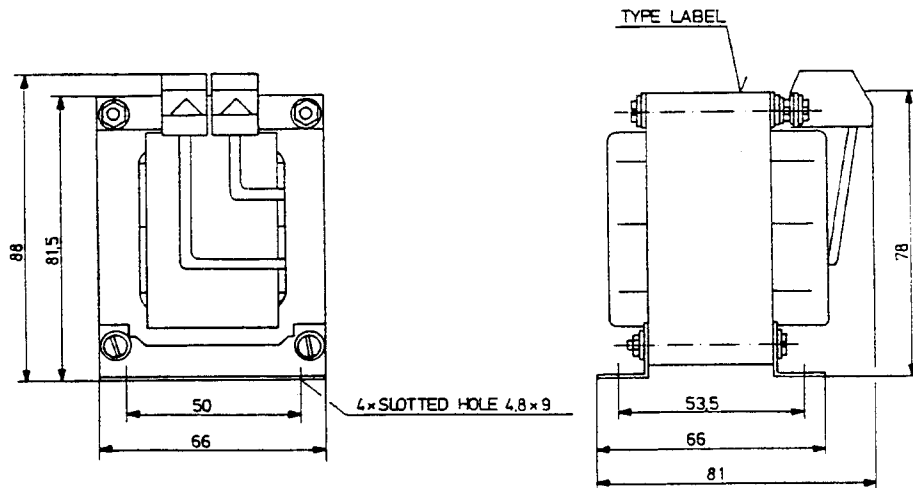

BPS 10 R-External Load Resistor

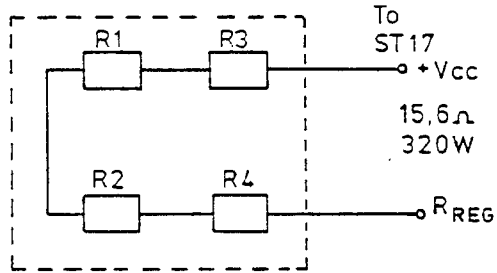

R 1 ... 4 = 3,9 Ω/80 W
I_{SWITCH} = 17,5 A
14352A

Assembly Drawing and Dimensions

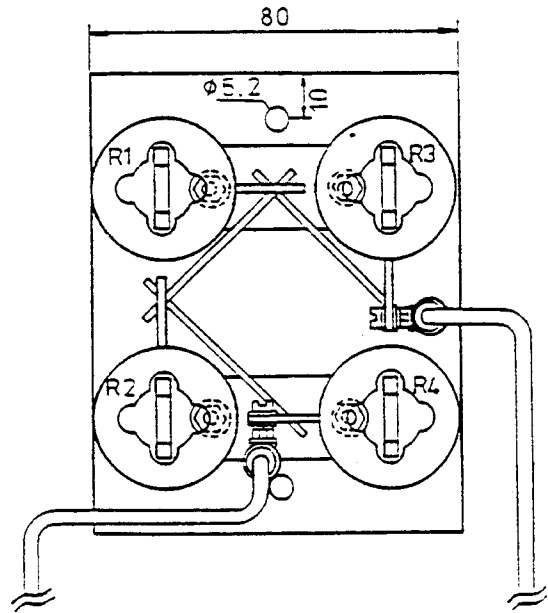
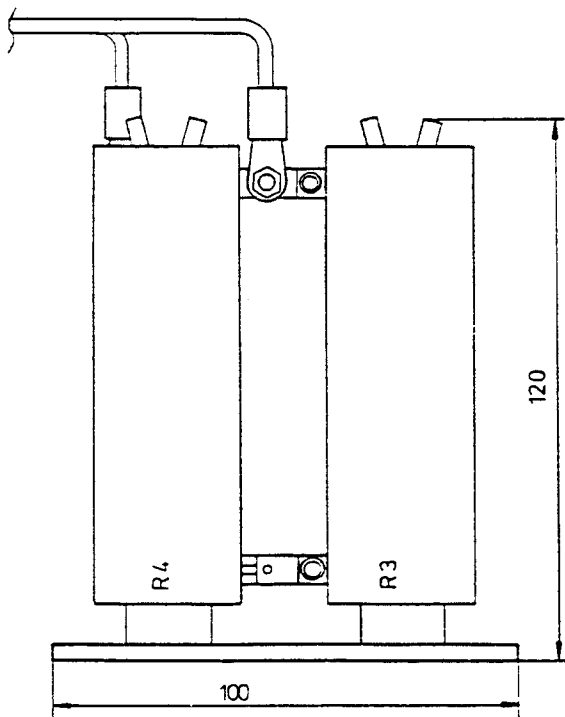

S-BTS 10 R - User Notes

1. Initial Phasing

In some cases the motorshaft cannot be decoupled from the load (ex. gearbox). Depending on friction, the torque generated during the phasing cycle can be too low. For these applications it is necessary to increase both the "phasing pwm value" (i53) and the "phase finding time" (i52).

2. Grounding

As shown on page 5 it is absolutely necessary to connect the power ground to earth to prevent damage on the RS232 interface.

3. Encoder-Feedback

The S-BTS 10 can also work with encoder feedback instead of resolver feedback. For encoder operation the jumpers E 10, E 11, E 12 have to be changed (see page 9). Also i40 has to be changed and set as follows:

$$i40 = \frac{8 \times \text{Enc. Res. (ppr)}}{\text{No. of poles}}$$

Encoder feedback is incremental; therefore automatic phasing is not possible: the motor will execute its phasing jumps after each power on.

The encoder signals have to be wired to the Handwheel inputs, consequently the Handwheel mode is not possible for this type of operation.

4. Offset Adjust

The current offsets are adjusted ex factory at an ambient temperature of 25° C.

At higher ambient temperatures a significant DC-component may be introduced in the motor windings due to thermal drift causing additional torque ripple.

Adjustment procedure:

- Remove S-BTS frontplate
- Power on
- Connect PC to S-BTS and start communication
- Enter 0ø (open loop, zero current command)
- Connect DVM to TP 1 (see page 23) and TP 8 (GND). Adjust R 2 (see page 10) until $V_{TP1} = 0,0 V_{DC}$
- Connect DVM to TP 2 and adjust to Zero with R 3
- Check TP 3 = 0,0 V_{DC}
- End.

S-BTS 10 R - User Notes (Continued)

5. Phase Offset & Phase Advance

The Phase Offset can be optimized (fine tuned) by the following procedure.

Jog the motor in both directions at about 50 % of the nominal speed.

Observe TP 1 (see page 23) with an oscilloscope and note the signal amplitudes for both directions.

Now optimize the offset by varying parameter i45 (std.) or i54 (parabolic) until the signal amplitudes are equal for both directions.

New values for i45/i54 are accepted by the S-BTS after entering a soft reset (\$).

The Phase Advance can be optimized with parameter i41 and should be set for lowest amplitude on TP 1.

Now slowly increase the motorspeed up to nominal and correct i45 (i54) and/or i41 if necessary.

Note: Phase offset tuning should be done with an unloaded motor since machine friction can be different for both directions.

Phase Advance tuning should be done with the loaded motor.

6. How to replace the Standard Chip Set by Parabolic and vice versa

a) Replace EPROM and CPU as required.

Caution: Please handle with great care and use appropriate tools. Also avoid electrostatic discharge.

b) Install push-button switches for

START (ST 12.1)
STOP (ST 12.2)
STEP (ST 12.3)

c) Disable Amplifier by taking ST 3/3 low (or left open).

d) With the IBM terminal connected and set to 9600 Baud, turn on power to system while shorting the STOP/ line to Ground. The μ SMCC will come in the test mode and you can then follow the instructions on the screen.

```
:RUN FOR PRESENT PARAMS
:STEP FOR DEFAULT PARAMS.....push Step
:RUN FOR BRUSHLESS PARAMS.....push Start
:STEP FOR STANDARD PARAMS
:RUN FOR 3-PHASE PARAMS.....push Start
:STEP FOR 4-PHASE PARAMS
:RUN SYNCHRONOUS PARAMS.....push Start
:STEP INDUCTION PARAMS
```

S-BTS 10 R - User Notes (Continued)

```
:SWITCH TEST  RUN.....push STOP to bypass any step
:SWITCH TEST  STEP
:SWITCH TEST  HOLD
:SWITCH TEST  HOME
:SWITCH TEST  EQUAL
:SWITCH TEST  JOG +X
:SWITCH TEST  JOG -X
:SWITCH TEST  JOG +Y
:SWITCH TEST  JOG -Y
:SWITCH TEST  LIMIT +X
:SWITCH TEST  LIMIT -X
:SWITCH TEST  LIMIT +Y
:SWITCH TEST  LIMIT -Y
: ENC-X  SNC-Y  HW-X  HW-Y
:      0      0      3      3
```

Use STOP/ key one more time to return to normal operating mode. Do not forget to use an "s" to save the parameters you have loaded.

- e) Now load default parameters from diskette

Standard: file name ipblstan
Parabolic: file name ipblparb

or change parameters according to the listings in this manual.

- f) Again do not forget to save the parameters you have changed.
- g) Remove power to the amplifier and proceed to normal set-up instructions.

7. 24 V-Option

The Control Supplies are normally generated from the 200 V_{DC} - BUS supply.

For some applications it is necessary to keep the control electronics on stand-by (ex. position information).

This can be achieved by using a supplementary external 24 V supply. In this case the internal supplies will be generated from the 24 V.

This feature is not standard and cannot be fitted in the field.