

ACCU ELECTRIC MOTORS INC

USA: (888) 932-9183

CANADA: (905) 829-2505

- ✓ Over 100 years cumulative experience
- ✓ 24 hour rush turnaround / technical support service
- ✓ Established in 1993



The leading independent repairer of servo motors and drives in North America.

Visit us on the web:

www.servo-repair.com

www.servorepair.ca

www.ferrocontrol.com

www.sandvikrepair.com

www.accuelectric.com

Scroll down to view your document!

For 24/7 repair services :

USA: 1 (888) 932 - 9183

Canada: 1 (905) 829 -2505

Emergency After hours: 1 (416) 624 0386

Servicing USA and Canada

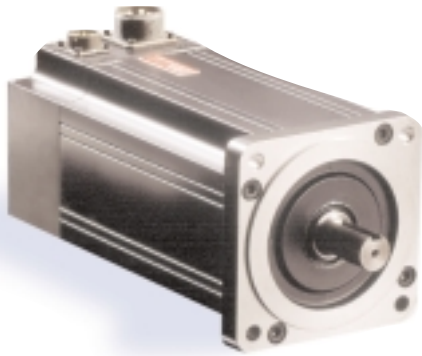
230 Series
TORQUE RANGE: 85-360 IN-LBS
9.6-40.7 Nm
Motor Data (Trap)

Motor Parameters		Units	1420ATG****	1420BTG****	1421ATG****	1421BTG****	1422ATG****
Horsepower	Hp Rated	Hp	2.9	1.6	4.4	2.9	6.8
Kilowatts	KW Rated	KW	2.1	1.2	3.3	2.1	5.1
Max. Operating Speed	N Max	RPM	2700	1750	2700	1750	2700
Speed @ Rated Torque	N Rated	RPM	2400	1300	2400	1500	2400
*Continuous Rated Torque @ Rated Speed		IN-LBS[Nm]	75.0[8.5]	78.0[8.8]	115.0[13.0]	120.0[13.5]	179.0[20.2]
*Continuous Stall Torque		IN-LBS[Nm]	85.0[9.6]	85.0[9.6]	130.0[14.7]	130.0[14.7]	210.0[23.7]
Continuous Line Current		AMPS	11.0	7.0	16.0	9.8	26.5
Peak Torque	Tpk	IN-LBS[Nm]	255.0[28.8]	255.0[28.8]	390.0[43.9]	390.0[43.9]	630.0[70.8]
Peak Current		AMPS	32.0	20.0	48.0	29.6	79.6
Max. Theoretical Accel.		RAD/SEC ²	39,231	39,231	36,792	36,792	33,511
Torque Sensitivity	Kt	IN-LBS/AMP[Nm/AMP]	7.9[0.89]	12.9[1.46]	7.9[0.89]	12.9[1.46]	7.9[0.89]
Back EMF (Line to Line)	±10%	Vrms/Krpm	70.0	115.0	70.0	115.0	70.0
D.C. Resistance (P-P)	±10%	OHMS	2.2	5.8	.66	1.7	.24
Inductance (P-P)	±10%	MILLIHENRIES	13.3	36	4.7	12.6	2.0
Rotor Inertia	Jm	IN-LBS-SEC ² [Kg-M ²]	.0065[.00073]	.0065[.00073]	.0106[.00119]	.0106[.00119]	.0188[.00212]
Static Friction	Tf	IN-LBS[Nm]	2.1[0.24]	2.1[0.24]	2.4[0.27]	2.4[0.27]	3.0[0.34]
Motor Weight		LBS[Kg]	27.0[12.2]	27.0[12.2]	36.0[16.3]	36.0[16.3]	51.0[23.1]
Line Voltage		VAC	230	230	230	230	230

Motor Parameters		Units	1422BTG****	1423ATG****	1423BTG****	1424ATG****	1424BTG****
Horsepower	Hp Rated	Hp	4.5	9.1	6.0	10.2	7.6
Kilowatts	KW Rated	KW	3.4	6.8	4.5	7.6	5.7
Max. Operating Speed	N Max	RPM	1750	2700	1750	2400	1750
Speed @ Rated Torque	N Rated	RPM	1500	2400	1500	2100	1500
*Continuous Rated Torque @ Rated Speed		IN-LBS[Nm]	190.0[21.3]	238.0[26.9]	252.0[28.2]	306.0[34.6]	320.0[36.0]
*Continuous Stall Torque		IN-LBS[Nm]	210.0[23.7]	280.0[31.5]	280.0[31.5]	360.0[40.7]	360.0[40.7]
Continuous Line Current		AMPS	15.8	35.4	21.1	34.0	27.1
Peak Torque	Tpk	IN-LBS[Nm]	630.0[70.8]	840.0[94.4]	840.0[94.4]	1081.0[122.2]	1081.0[122.2]
Peak Current		AMPS	47.4	106.3	63.2	102.0	81.3
Max. Theoretical Accel.		RAD/SEC ²	33,511	30,769	30,769	30,710	30,710
Torque Sensitivity	Kt	IN-LBS/AMP[Nm/AMP]	12.9[1.46]	7.9[0.89]	12.9[1.46]	10.4[1.2]	12.9[1.46]
Back EMF (Line to Line)	±10%	Vrms/Krpm	115.0	70.0	115.0	93.0	115.0
D.C. Resistance (P-P)	±10%	OHMS	.72	.13	.45	.18	.26
Inductance (P-P)	±10%	MILLIHENRIES	6.1	1.4	4.3	1.7	2.9
Rotor Inertia	Jm	IN-LBS-SEC ² [Kg-M ²]	.0188[.00212]	.0273[.00308]	.0273[.00308]	.0352[.00397]	.0352[.00397]
Static Friction	Tf	IN-LBS[Nm]	3.0[0.34]	3.6[0.41]	3.6[0.41]	4.2[0.47]	4.2[0.47]
Motor Weight		LBS[Kg]	51.0[23.1]	66.0[29.9]	66.0[29.9]	83.0[37.7]	83.0[37.7]
Line Voltage		VAC	230	230	230	230	230

Brake Info:

Min. Holding Torque: 360 IN-LBS
Input Voltage: 24VDC
Current: 1.13 AMPS
Inertia: .00227 IN-LB-SEC²
Weight Added: 12 LBS

*25° C Ambient with a maximum case temperature of 100° C on motor. Motor mounted on a 12" x 12" x 1/2" aluminum heatsink. Thermostat in stator windings will open if winding temperature exceeds 155° C. This allows for an approximate +10% headroom in the continuous torque rating before thermostat opens.

Mechanical Notes:

1. Axial Load: 50 LBS. Max.
2. Radial Load: 150 LBS. Max. @ 1" from face
3. Motor Sealed to IP65

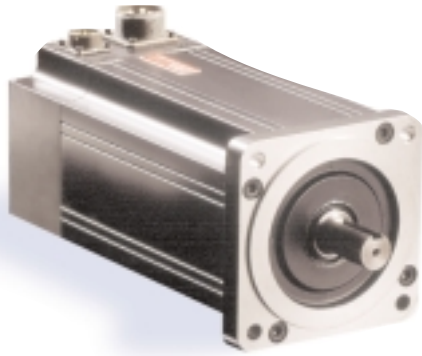
230 Series
TORQUE RANGE: 85-360 IN-LBS
9.6-40.7 Nm
Motor Data (Sine)

Motor Parameters		Units	1420ASG****	1420BSG****	1421ASG****	1421BSG****	1422ASG****
Horsepower	Hp Rated	Hp	2.9	1.6	4.4	2.9	6.8
Kilowatts	KW Rated	KW	2.1	1.2	3.3	2.1	5.1
Max. Operating Speed	N Max	RPM	2700	1750	2700	1750	2700
Speed @ Rated Torque	N Rated	RPM	2400	1300	2400	1500	2400
*Continuous Rated Torque @ Rated Speed		IN-LBS[Nm]	75.0[8.5]	78.0[8.8]	115.0[13.0]	120.0[13.5]	179.0[20.2]
*Continuous Stall Torque		IN-LBS[Nm]	85.0[9.6]	85.0[9.6]	130.0[14.7]	130.0[14.7]	210.0[23.7]
Continuous Line Current		AMPS(RMS ϕ)	7.7	4.9	11.3	6.9	18.7
Peak Torque	Tpk	IN-LBS[Nm]	255.0[28.8]	255.0[28.8]	390.0[43.9]	390.0[43.9]	630.0[70.8]
Peak Current		AMPS(RMS ϕ)	22.6	14.1	33.9	20.9	56.3
Max. Theoretical Accel.		RAD/SEC ²	39,231	39,231	36,792	36,792	33,511
Torque Sensitivity	Kt	IN-LBS/AMP(RMS ϕ)[Nm/AMP(RMS ϕ)]	11.1[1.25]	18.2[2.06]	11.2[1.26]	18.8[2.06]	11.2[1.26]
Back EMF (Line to Line)	$\pm 10\%$	Vrms/Krpm	70.0	115.0	70.0	115.0	70.0
D.C. Resistance (P-P)	$\pm 10\%$	OHMS	2.2	5.8	.66	1.7	.24
Inductance (P-P)	$\pm 10\%$	MILLIHENRIES	13.3	36	4.7	12.6	2.0
Rotor Inertia	Jm	IN-LBS-SEC ² [Kg-M ²]	.0065[.00073]	.0065[.00073]	.0106[.00119]	.0106[.00119]	.0188[.00212]
Static Friction	Tf	IN-LBS[Nm]	2.1[0.24]	2.1[0.24]	2.4[0.27]	2.4[0.27]	3.0[0.34]
Motor Weight		LBS[Kg]	27.0[12.2]	27.0[12.2]	36.0[16.3]	36.0[16.3]	51.0[23.1]
Line Voltage		VAC	230	230	230	230	230

Motor Parameters		Units	1422BSG****	1423ASG****	1423BSG****	1424ASG****	1424BSG****
Horsepower	Hp Rated	Hp	4.5	9.1	6.0	10.2	7.6
Kilowatts	KW Rated	KW	3.4	6.8	4.5	7.6	5.7
Max. Operating Speed	N Max	RPM	1750	2700	1750	2400	1750
Speed @ Rated Torque	N Rated	RPM	1500	2400	1500	2100	1500
*Continuous Rated Torque @ Rated Speed		IN-LBS[Nm]	190.0[21.3]	238.0[26.9]	252.0[28.2]	306.0[34.6]	320.0[36.0]
*Continuous Stall Torque		IN-LBS[Nm]	210.0[23.7]	280.0[31.5]	280.0[31.5]	360.0[40.7]	360.0[40.7]
Continuous Line Current		AMPS(RMS ϕ)	11.2	25.0	14.9	24.0	19.2
Peak Torque	Tpk	IN-LBS[Nm]	630.0[70.8]	840.0[94.4]	840.0[94.4]	1081.0[122.2]	1081.0[122.2]
Peak Current		AMPS(RMS ϕ)	33.511	75.2	44.7	72.1	57.5
Max. Theoretical Accel.		RAD/SEC ²	33,511	30,769	30,769	30,710	30,710
Torque Sensitivity	Kt	IN-LBS/AMP(RMS ϕ)[Nm/AMP(RMS ϕ)]	18.2[2.06]	11.2[1.26]	18.2[2.06]	15.0[1.70]	18.2[2.06]
Back EMF (Line to Line)	$\pm 10\%$	Vrms/Krpm	115.0	70.0	115.0	93.0	115.0
D.C. Resistance (P-P)	$\pm 10\%$	OHMS	.72	.13	.45	.18	.26
Inductance (P-P)	$\pm 10\%$	MILLIHENRIES	6.1	1.4	4.3	1.7	2.9
Rotor Inertia	Jm	IN-LBS-SEC ² [Kg-M ²]	.0188[.00212]	.0273[.00308]	.0273[.00308]	.0352[.00397]	.0352[.00397]
Static Friction	Tf	IN-LBS[Nm]	3.0[0.34]	3.6[0.41]	3.6[0.41]	4.2[0.47]	4.2[0.47]
Motor Weight		LBS[Kg]	51.0[23.1]	66.0[29.9]	66.0[29.9]	83.0[37.7]	83.0[37.7]
Line Voltage		VAC	230	230	230	230	230

Brake Info:

Min. Holding Torque: 360 IN-LBS
Input Voltage: 24VDC
Current: 1.13 AMPS
Inertia: .00227 IN-LB-SEC²
Weight Added: 12 LBS

*25° C Ambient with a maximum case temperature of 100° C on motor. Motor mounted on a 12" x 12" x 1/2" aluminum heatsink. Thermostat in stator windings will open if winding temperature exceeds 155° C. This allows for an approximate +10% headroom in the continuous torque rating before thermostat opens.

Mechanical Notes:

1. Axial Load: 50 LBS. Max.
2. Radial Load: 150 LBS. Max. @ 1" from face
3. Motor Sealed to IP65

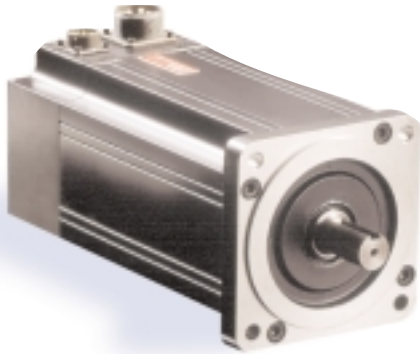
460 Series
TORQUE RANGE: 85-360 IN-LBS
9.6-40.7 Nm
Motor Data (Trap)

Motor Parameters		Units	1420CTJ****	1420DTJ****	1421CTJ****	1421DTJ****	1422CTJ****
Horsepower	Hp Rated	Hp	3.1	1.6	4.9	2.9	7.5
Kilowatts	KW Rated	KW	2.3	1.2	3.6	2.1	5.7
Max. Operating Speed	N Max	RPM	3400	1750	3400	1750	3400
Speed @ Rated Torque	N Rated	RPM	2800	1300	2800	1500	2800
*Continuous Rated Torque @ Rated Speed		IN-LBS[Nm]	70.0[9.9]	78.0[8.8]	110.0[12.4]	120.0[13.5]	170.0[19.2]
*Continuous Stall Torque		IN-LBS[Nm]	85.0[9.6]	85.0[9.6]	130.0[14.7]	130.0[14.7]	210.0[23.7]
Continuous Line Current		AMPS	7.0	3.0	9.8	4.9	15.8
Peak Torque	Tpk	IN-LBS[Nm]	255.0[28.8]	255.0[28.8]	390.0[43.9]	390.0[43.9]	630.0[70.8]
Peak Current		AMPS	20.0	10.0	29.6	14.8	47.4
Max. Theoretical Accel.		RAD/SEC ²	39,231	39,231	36,792	36,792	33,511
Torque Sensitivity	Kt	IN-LBS/AMP[Nm/AMP]	12.9[1.46]	25.8[2.92]	12.9[1.46]	25.8[2.92]	12.9[1.46]
Back EMF (Line to Line)	±10%	Vrms/Krpm	115.0	230.0	115.0	230.0	115.0
D.C. Resistance (P-P)	±10%	OHMS	5.8	23	1.9	7.1	.68
Inductance (P-P)	±10%	MILLIHENRIES	36	143	13.0	52.3	5.6
Rotor Inertia	Jm	IN-LBS-SEC ² [Kg-M ²]	.0065[.00073]	.0065[.00073]	.0106[.00119]	.0106[.00119]	.0188[.00212]
Static Friction	Tf	IN-LBS[Nm]	2.1[0.24]	2.1[0.24]	2.4[0.27]	2.4[0.27]	3.0[0.34]
Motor Weight		LBS[Kg]	27.0[12.2]	27.0[12.2]	36.0[16.3]	36.0[16.3]	51.0[23.1]
Line Voltage		VAC	460	460	460	460	460

Motor Parameters		Units	1422DTJ****	1423CTJ****	1423DTJ****	1424CTJ****	1424DTJ****
Horsepower	Hp Rated	Hp	4.5	9.8	6.0	12.4	7.6
Kilowatts	KW Rated	KW	3.4	7.3	4.5	9.3	5.7
Max. Operating Speed	N Max	RPM	1750	3400	1750	3400	1750
Speed @ Rated Torque	N Rated	RPM	1500	2800	1500	2800	1500
*Continuous Rated Torque @ Rated Speed		IN-LBS[Nm]	190.0[21.3]	220.0[24.8]	252.0[28.2]	280.0[31.6]	320.0[36.0]
*Continuous Stall Torque		IN-LBS[Nm]	210.0[23.7]	280.0[31.5]	280.0[31.5]	360.0[40.7]	360.0[40.7]
Continuous Line Current		AMPS	7.9	21.1	10.6	27.1	13.6
Peak Torque	Tpk	IN-LBS[Nm]	630.0[70.8]	840.0[94.4]	840.0[94.4]	1081.0[122.2]	1081.0[122.2]
Peak Current		AMPS	23.7	63.2	31.6	81.3	40.6
Max. Theoretical Accel.		RAD/SEC ²	33,511	30,769	30,769	30,710	30,710
Torque Sensitivity	Kt	IN-LBS/AMP[Nm/AMP]	25.8[2.92]	12.9[1.46]	25.8[2.92]	12.9[1.46]	25.8[2.92]
Back EMF (Line to Line)	±10%	Vrms/Krpm	230.0	115.0	230.0	115.0	230.0
D.C. Resistance (P-P)	±10%	OHMS	2.5	.45	1.7	.26	1.2
Inductance (P-P)	±10%	MILLIHENRIES	23.0	4.3	16.9	2.9	11.1
Rotor Inertia	Jm	IN-LBS-SEC ² [Kg-M ²]	.0188[.00212]	.0273[.00308]	.0273[.00308]	.0352[.00397]	.0352[.00397]
Static Friction	Tf	IN-LBS[Nm]	3.0[0.34]	3.6[0.41]	3.6[0.41]	4.2[0.47]	4.2[0.47]
Motor Weight		LBS[Kg]	51.0[23.1]	66.0[29.9]	66.0[29.9]	83.0[37.7]	83.0[37.7]
Line Voltage		VAC	460	460	460	460	460

Brake Info:

Min. Holding Torque: 360 IN-LBS
Input Voltage: 24VDC
Current: 1.13 AMPS
Inertia: .00227 IN-LB-SEC²
Weight Added: 12 LBS

*25° C Ambient with a maximum case temperature of 100° C on motor. Motor mounted on a 12" x 12" x 1/2" aluminum heatsink. Thermostat in stator windings will open if winding temperature exceeds 155° C. This allows for an approximate +10% headroom in the continuous torque rating before thermostat opens.

Mechanical Notes:

1. Axial Load: 50 LBS. Max.
2. Radial Load: 150 LBS. Max. @ 1" from face
3. Motor Sealed to IP65

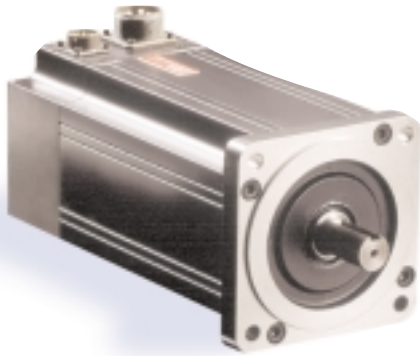
460 Series
TORQUE RANGE: 85-360 IN-LBS
9.6-40.7 Nm
Motor Data (Sine)

Motor Parameters		Units	1420CSJ****	1420DSJ****	1421CSJ****	1421DSJ****	1422CSJ****
Horsepower	Hp Rated	Hp	3.1	1.6	4.9	2.9	7.5
Kilowatts	KW Rated	KW	2.3	1.2	3.6	2.1	5.7
Max. Operating Speed	N Max	RPM	3400	1750	3400	1750	3400
Speed @ Rated Torque	N Rated	RPM	2800	1300	2800	1500	2800
*Continuous Rated Torque @ Rated Speed		IN-LBS[Nm]	70.0[7.9]	78.0[8.8]	110.0[12.4]	120.0[13.5]	170.0[19.2]
*Continuous Stall Torque		IN-LBS[Nm]	85.0[9.6]	85.0[9.6]	130.0[14.7]	130.0[14.7]	210.0[23.7]
Continuous Line Current		AMPS/(RMS/φ)	4.9	2.1	6.9	3.5	11.2
Peak Torque	Tpk	IN-LBS[Nm]	255.0[28.8]	255.0[28.8]	390.0[43.9]	390.0[43.9]	630.0[70.8]
Peak Current		AMPS/(RMS/φ)	14.1	7.1	20.9	10.5	33.5
Max. Theoretical Accel.		RAD/SEC ²	39,231	39,231	36,792	36,792	33,511
Torque Sensitivity	Kt	IN-LBS/AMP/(RMS/φ)[Nm/AMP/(RMS/φ)]	18.2[2.06]	36.5[4.1]	18.2[2.1]	36.5[4.1]	18.2[2.1]
Back EMF (Line to Line)	±10%	Vrms/Krpm	115.0	230.0	115.0	230.0	115.0
D.C. Resistance (P-P)	±10%	OHMS	5.8	23	1.9	7.1	.68
Inductance (P-P)	±10%	MILLIHENRIES	36	143	13.0	52.3	5.6
Rotor Inertia	Jm	IN-LBS-SEC ² [Kg-M ²]	.0065[.00073]	.0065[.00073]	.0106[.00119]	.0106[.00119]	.0188[.00212]
Static Friction	Tf	IN-LBS[Nm]	2.1[0.24]	2.1[0.24]	2.4[0.27]	2.4[0.27]	3.0[0.34]
Motor Weight		LBS[Kg]	27.0[12.2]	27.0[12.2]	36.0[16.3]	36.0[16.3]	51.0[23.1]
Line Voltage		VAC	460	460	460	460	460

Motor Parameters		Units	1422DSJ****	1423CSJ****	1423DSJ****	1424CSJ****	1424DSJ****
Horsepower	Hp Rated	Hp	4.5	9.8	6.0	12.4	7.6
Kilowatts	KW Rated	KW	3.4	7.3	4.5	9.3	5.7
Max. Operating Speed	N Max	RPM	1750	3400	1750	3400	1750
Speed @ Rated Torque	N Rated	RPM	1500	2800	1500	2800	1500
*Continuous Rated Torque @ Rated Speed		IN-LBS[Nm]	190.0[21.3]	220.0[24.8]	252.0[28.2]	280.0[31.6]	320.0[36.0]
*Continuous Stall Torque		IN-LBS[Nm]	210.0[23.7]	280.0[31.5]	280.0[31.5]	360.0[40.7]	360.0[40.7]
Continuous Line Current		AMPS/(RMS/φ)	5.6	14.9	7.5	19.2	9.6
Peak Torque	Tpk	IN-LBS[Nm]	630.0[70.8]	840.0[94.4]	840.0[94.4]	1081.0[122.2]	1081.0[122.2]
Peak Current		AMPS/(RMS/φ)	16.8	44.7	22.3	57.5	28.7
Max. Theoretical Accel.		RAD/SEC ²	33,511	30,769	30,769	30,710	30,710
Torque Sensitivity	Kt	IN-LBS/AMP/(RMS/φ)[Nm/AMP/(RMS/φ)]	36.5[4.1]	18.2[2.1]	36.5[4.1]	18.2[2.1]	36.5[4.1]
Back EMF (Line to Line)	±10%	Vrms/Krpm	230.0	115.0	230.0	115.0	230.0
D.C. Resistance (P-P)	±10%	OHMS	2.5	.45	1.7	.26	1.2
Inductance (P-P)	±10%	MILLIHENRIES	23.0	4.3	16.9	2.9	11.1
Rotor Inertia	Jm	IN-LBS-SEC ² [Kg-M ²]	.0188[.00212]	.0273[.00308]	.0273[.00308]	.0352[.00397]	.0352[.00397]
Static Friction	Tf	IN-LBS[Nm]	3.0[0.34]	3.6[0.41]	3.6[0.41]	4.2[0.47]	4.2[0.47]
Motor Weight		LBS[Kg]	51.0[23.1]	66.0[29.9]	83.0[37.7]	83.0[37.7]	
Line Voltage		VAC	460	460	460	460	

Brake Info:

Min. Holding Torque: 360 IN-LBS
Input Voltage: 24VDC
Current: 1.13 AMPS
Inertia: .00227 IN-LB-SEC²
Weight Added: 12 LBS

*25° C Ambient with a maximum case temperature of 100° C on motor. Motor mounted on a 12" x 12" x 1/2" aluminum heatsink. Thermostat in stator windings will open if winding temperature exceeds 155° C. This allows for an approximate +10% headroom in the continuous torque rating before thermostat opens.

Mechanical Notes:

1. Axial Load: 50 LBS. Max.
2. Radial Load: 150 LBS. Max. @ 1" from face
3. Motor Sealed to IP65

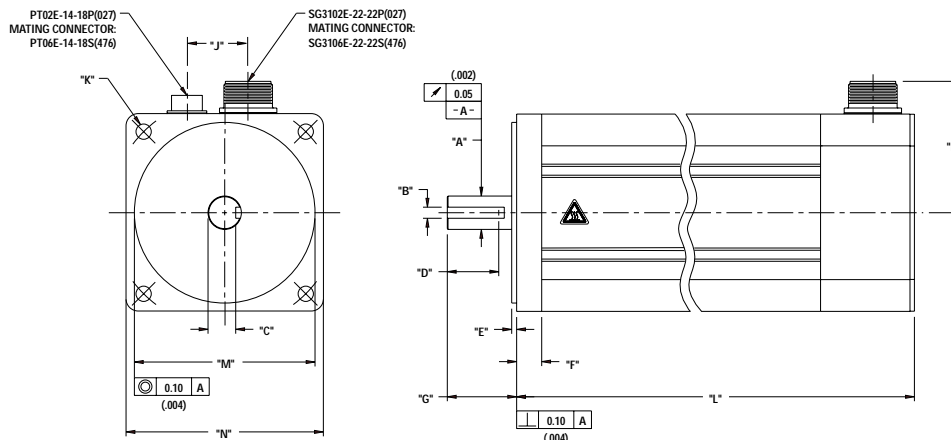

6" (142) English and Metric Connectorized Termination-Option 1 Motors

Model	"A"	"B"	"C"	"D"	"E"	"F"	"G"
MPM1420***6***	∅ .8750 (22.225) .8745 (22.212)	.1890 (4.801) .1875 (4.763)	.774 (19.66)	1.41 (35.8) Min	.13 (3.2)	.73 (18.4)	1.97 (50.0) 1.93 (49.0)
MPM1420***7***	∅ 24.000 (9449) 23.988 (9444)	7.998 (.3149) 7.963 (.3135)	19.91 (.784)	37.0 (1.46) Min	3.6 (.14)	18.0 (.71)	50.5 (1.99) 49.5 (1.95)
MPM1421***6***	∅ .8750 (22.225) .8745 (22.212)	.1890 (4.801) .1875 (4.763)	.774 (19.66)	1.41 (35.8) Min	.13 (3.2)	.73 (18.4)	1.97 (50.0) 1.93 (49.0)
MPM1421***7***	∅ 24.000 (9449) 23.988 (9444)	7.998 (.3149) 7.963 (.3135)	19.91 (.784)	37.0 (1.46) Min	3.6 (.14)	18.0 (.71)	50.5 (1.99) 49.5 (1.95)
MPM1422***6***	∅ .8750 (22.225) .8745 (22.212)	.1890 (4.801) .1875 (4.763)	.774 (19.66)	1.41 (35.8) Min	.13 (3.2)	.73 (18.4)	1.97 (50.0) 1.93 (49.0)
MPM1422***7***	∅ 24.000 (9449) 23.988 (9444)	7.998 (.3149) 7.963 (.3135)	19.91 (.784)	37.0 (1.46) Min	3.6 (.14)	18.0 (.71)	50.5 (1.99) 49.5 (1.95)
MPM1423***6***	∅ .8750 (22.225) .8745 (22.212)	.1890 (4.801) .1875 (4.763)	.774 (19.66)	1.41 (35.8) Min	.13 (3.2)	.73 (18.4)	1.97 (50.0) 1.93 (49.0)
MPM1423***7***	∅ 31.999 (1.2598) 31.986 (1.2593)	10.000 (.3937) 9.964 (.3923)	26.90 (1.059)	37.0 (1.46) Min	3.6 (.14)	18.0 (.71)	50.5 (1.99) 49.5 (1.95)
MPM1424***6***	∅ .8750 (22.225) .8745 (22.212)	.1890 (4.801) .1875 (4.763)	.774 (19.66)	1.41 (35.8) Min	.13 (3.2)	.73 (18.4)	1.97 (50.0) 1.93 (49.0)
MPM1424***7***	∅ 31.999 (1.2598) 31.986 (1.2593)	10.000 (.3937) 9.964 (.3923)	26.90 (1.059)	37.0 (1.46) Min	3.6 (.14)	18.0 (.71)	50.5 (1.99) 49.5 (1.95)

Model	"H"	"J"	"K"	"L"	"L" w/ Brake	"M"	"N"
MPM1420***6***	3.7 (95) Max	1.74 (44.1)	3/8-16UNC-2B THRU (4) EQ SPD AS SHOWN ON ∅5.875 (149.22) B.C.	9.96 (253.0) Max	12.66 (321.6) Max	∅ 4.500 (114.30) 4.499 (114.27)	□ 5.59 (142.0)
MPM1420***7***	95 (3.7) Max	44.1 (1.74)	∅11.00 (.433) THRU (4) EQ SPD AS SHOWN ON ∅165.00 (6.496) B.C.	252.5 (9.94) Max	321.1 (12.64) Max	∅ 130.00 (5.118) 129.97 (5.117)	□ 142.0 (5.59)
MPM1421***6***	3.7 (95) Max	1.74 (44.1)	3/8-16UNC-2B THRU (4) EQ SPD AS SHOWN ON ∅5.875 (149.22) B.C.	11.31 (287.3) Max	14.01 (355.9) Max	∅ 4.500 (114.30) 4.499 (114.27)	□ 5.59 (142.0)
MPM1421***7***	95 (3.7) Max	44.1 (1.74)	∅11.00 (.433) THRU (4) EQ SPD AS SHOWN ON ∅165.00 (6.496) B.C.	286.8 (11.29) Max	355.3 (13.99) Max	∅ 130.00 (5.118) 129.97 (5.117)	□ 142.0 (5.59)
MPM1422***6***	3.7 (95) Max	1.74 (44.1)	3/8-16UNC-2B THRU (4) EQ SPD AS SHOWN ON ∅5.875 (149.22) B.C.	14.01 (355.9) Max	16.71 (424.4) Max	∅ 4.500 (114.30) 4.499 (114.27)	□ 5.59 (142.0)
MPM1422***7***	95 (3.7) Max	44.1 (1.74)	∅11.00 (.433) THRU (4) EQ SPD AS SHOWN ON ∅165.00 (6.496) B.C.	355.3 (13.99) Max	423.9 (16.69) Max	∅ 130.00 (5.118) 129.97 (5.117)	□ 142.0 (5.59)
MPM1423***6***	3.7 (95) Max	1.74 (44.1)	3/8-16UNC-2B THRU (4) EQ SPD AS SHOWN ON ∅5.875 (149.22) B.C.	16.71 (424.4) Max	19.41 (493.0) Max	∅ 4.500 (114.30) 4.499 (114.27)	□ 5.59 (142.0)
MPM1423***7***	95 (3.7) Max	44.1 (1.74)	∅11.00 (.433) THRU (4) EQ SPD AS SHOWN ON ∅165.00 (6.496) B.C.	423.9 (16.69) Max	492.5 (19.39) Max	∅ 130.00 (5.118) 129.97 (5.117)	□ 142.0 (5.59)
MPM1424***6***	3.7 (95) Max	1.74 (44.1)	3/8-16UNC-2B THRU (4) EQ SPD AS SHOWN ON ∅5.875 (149.22) B.C.	19.41 (493.0) Max	22.11 (561.6) Max	∅ 4.500 (114.30) 4.499 (114.27)	□ 5.59 (142.0)
MPM1424***7***	95 (3.7) Max	44.1 (1.74)	∅11.00 (.433) THRU (4) EQ SPD AS SHOWN ON ∅165.00 (6.496) B.C.	492.5 (19.39) Max	561.1 (22.09) Max	∅ 130.00 (5.118) 129.97 (5.117)	□ 142.0 (5.59)

English = 6
Metric = 7

For Mechanical Dimensions on Termination Option 2 Consult Factory.



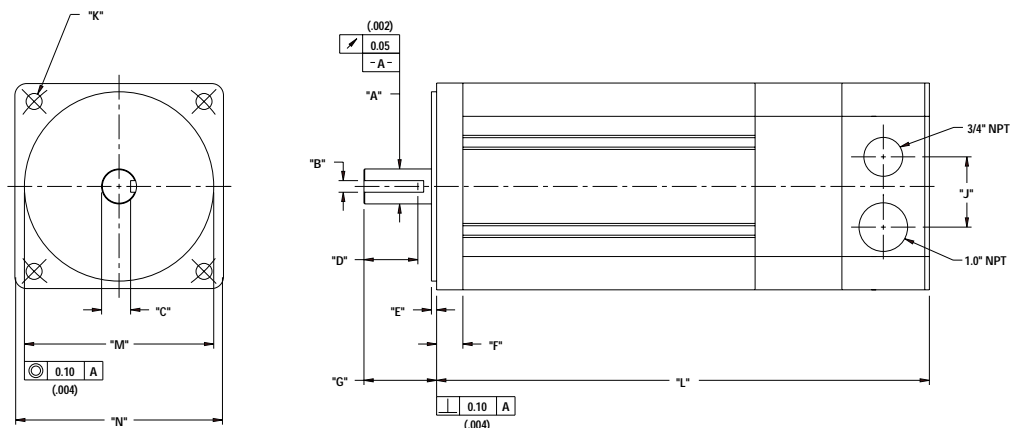

6" (142) English and Metric NPT Termination-Option 3 Motors

Model	"A"	"B"	"C"	"D"	"E"	"F"	"G"
MPM1420***6***	∅ .8750 (22.225) ∅ .8745 (22.212)	.1890 (4.801) .1875 (4.763)	.774 (19.66)	1.41 (35.8) Min	.13 (3.2)	.73 (18.4)	1.97 (50.0) 1.93 (49.0)
MPM1420***7***	∅ 24.000 (.9449) ∅ 23.988 (.9444)	7.998 (.3149) 7.963 (.3135)	19.91 (.784)	37.0 (1.46) Min	3.6 (.14)	18.0 (.71)	50.4 (1.98) 49.4 (1.94)
MPM1421***6***	∅ .8750 (22.225) ∅ .8745 (22.212)	.1890 (4.801) .1875 (4.763)	.774 (19.66)	1.41 (35.8) Min	.13 (3.2)	.73 (18.4)	1.97 (50.0) 1.93 (49.0)
MPM1421***7***	∅ 24.000 (.9449) ∅ 23.988 (.9444)	7.998 (.3149) 7.963 (.3135)	19.91 (.784)	37.0 (1.46) Min	3.6 (.14)	18.0 (.71)	50.4 (1.98) 49.4 (1.94)
MPM1422***6***	∅ .8750 (22.225) ∅ .8745 (22.212)	.1890 (4.801) .1875 (4.763)	.774 (19.66)	1.41 (35.8) Min	.13 (3.2)	.73 (18.4)	1.97 (50.0) 1.93 (49.0)
MPM1422***7***	∅ 24.000 (.9449) ∅ 23.988 (.9444)	7.998 (.3149) 7.963 (.3135)	19.91 (.784)	37.0 (1.46) Min	3.6 (.14)	18.0 (.71)	50.4 (1.98) 49.4 (1.94)
MPM1423***6***	∅ .8750 (22.225) ∅ .8745 (22.212)	.1890 (4.801) .1875 (4.763)	.774 (19.66)	1.41 (35.8) Min	.13 (3.2)	.73 (18.4)	1.97 (50.0) 1.93 (49.0)
MPM1423***7***	∅ 31.999 (1.2598) ∅ 31.986 (1.2593)	10.000 (.3937) 9.964 (.3923)	26.90 (1.059)	37.0 (1.46) Min	3.6 (.14)	18.0 (.71)	50.4 (1.98) 49.4 (1.94)
MPM1424***6***	∅ .8750 (22.225) ∅ .8745 (22.212)	.1890 (4.801) .1875 (4.763)	.774 (19.66)	1.41 (35.8) Min	.13 (3.2)	.73 (18.4)	1.97 (50.0) 1.93 (49.0)
MPM1424***7***	∅ 31.999 (1.2598) ∅ 31.986 (1.2593)	10.000 (.3937) 9.964 (.3923)	26.90 (1.059)	37.0 (1.46) Min	3.6 (.14)	18.0 (.71)	50.4 (1.98) 49.4 (1.94)

Model	"J"	"K"	"L"	"L" w/ Brake	"M"	"N"
MPM1420***6***	1.90 (48.3)	3/8-16UNC-2B THRU (4) EQ SPD AS SHOWN ON ∅5.875 (149.22) B.C.	12.02 (305.3) Max	14.72 (373.9) Max	∅ 4.500 (114.30) ∅ 4.499 (114.27)	□ 5.59 (142.0)
MPM1420***7***	48.3 (1.90)	∅11.00 (.433) THRU (4) EQ SPD AS SHOWN ON ∅165.00 (6.496) B.C.	304.8 (12.00) Max	373.4 (14.70) Max	∅ 130.00 (5.118) ∅ 129.97 (5.117)	□ 142.0 (5.59)
MPM1421***6***	1.90 (48.3)	3/8-16UNC-2B THRU (4) EQ SPD AS SHOWN ON ∅5.875 (149.22) B.C.	13.37 (339.6) Max	16.07 (408.2) Max	∅ 4.500 (114.30) ∅ 4.499 (114.27)	□ 5.59 (142.0)
MPM1421***7***	48.3 (1.90)	∅11.00 (.433) THRU (4) EQ SPD AS SHOWN ON ∅165.00 (6.496) B.C.	339.0 (13.35) Max	408.0 (16.05) Max	∅ 130.00 (5.118) ∅ 129.97 (5.117)	□ 142.0 (5.59)
MPM1422***6***	1.90 (48.3)	3/8-16UNC-2B THRU (4) EQ SPD AS SHOWN ON ∅5.875 (149.22) B.C.	16.07 (408.2) Max	18.77 (476.8) Max	∅ 4.500 (114.30) ∅ 4.499 (114.27)	□ 5.59 (142.0)
MPM1422***7***	48.3 (1.90)	∅11.00 (.433) THRU (4) EQ SPD AS SHOWN ON ∅165.00 (6.496) B.C.	408.0 (16.05) Max	477.0 (18.75) Max	∅ 130.00 (5.118) ∅ 129.97 (5.117)	□ 142.0 (5.59)
MPM1423***6***	1.90 (48.3)	3/8-16UNC-2B THRU (4) EQ SPD AS SHOWN ON ∅5.875 (149.22) B.C.	18.77 (476.8) Max	21.47 (545.3) Max	∅ 4.500 (114.30) ∅ 4.499 (114.27)	□ 5.59 (142.0)
MPM1423***7***	48.3 (1.90)	∅11.00 (.433) THRU (4) EQ SPD AS SHOWN ON ∅165.00 (6.496) B.C.	477.0 (18.75) Max	546.0 (21.45) Max	∅ 130.00 (5.118) ∅ 129.97 (5.117)	□ 142.0 (5.59)
MPM1424***6***	1.90 (48.3)	3/8-16UNC-2B THRU (4) EQ SPD AS SHOWN ON ∅5.875 (149.22) B.C.	21.47 (545.3) Max	24.17 (613.9) Max	∅ 4.500 (114.30) ∅ 4.499 (114.27)	□ 5.59 (142.0)
MPM1424***7***	48.3 (1.90)	∅11.00 (.433) THRU (4) EQ SPD AS SHOWN ON ∅165.00 (6.496) B.C.	546.0 (21.45) Max	613.3 (24.15) Max	∅ 130.00 (5.118) ∅ 129.97 (5.117)	□ 142.0 (5.59)

English = 6
Metric = 7

For Mechanical Dimensions on Termination Option 2 Consult Factory.





6" Motor with Resolver Feedback

Option 1

Motor Connector 270-00017 (SG3102E-22-22P(027))

Pin	Function	Wire Color
A	ϕ R	RED
B	ϕ S	BLACK
C	ϕ T	BLUE
D	PE GND	GRN/YEL



Resolver Connector 270-00024 (PT02E-14-18P(027))

Pin	Function	Wire Color
U	THERM	BLACK
N	THERM	BLACK
H	SIN	YELLOW
G	COS GND	BLACK
S	COS	RED
F	SIN GND	BLUE
R	REF GND	YEL/WHT
E	REF	RED/WHT
D	RES SHLD	GRN/YEL
P	GND	GRN/YEL
*A	BRK (+) 	DIODE
*B	BRK (-) 	1N4007
*C	BRK SHLD	-
J	-	-
K	-	-
L	-	-
M	-	-
T	-	-

* USE ONLY WITH BRAKE OPTION

Option 2

Motor Connector 270-00325 (CEGA258NN0000001000)

Pin	Function	Wire Color
U	ϕ R(U1)	RED
V	ϕ S(V1)	BLACK
W	ϕ T(W1)	BLUE
PE	PE GND	GRN/YEL
*+	BRK (+) 	DIODE
*-	BRK (-) 	1N4007
1	THERM	BLACK
2	THERM	BLACK



* USE ONLY WITH BRAKE OPTION

Resolver Connector 270-00257 (AEGA052NN00000013000)

Pin	Function	Wire Color
1	-	-
2	REF (R1)	RED/WHT
3	REF GND (R2)	YEL/WHT
4	COS GND (S1)	BLACK
5	COS (S3)	RED
6	SIN (S2)	YELLOW
7	SIN GND (S4)	BLUE
8	-	-
9	-	-
10	-	-
11	-	-
12	-	-

Option 3

Connection Chart (NPT) Resolver

Terminal	Function	Wire Color	Terminal Block
1	ϕ R	RED	TB3 (MOTOR CONN)
2	ϕ S	BLACK	
3	ϕ T	BLUE	
4	PE GND	GRN/YEL	
*S11	BRK (+) 	BLUE	TB2 (BRAKE CONN)
*S10	BRK (-) 	BLUE	
S9	REF GND	YEL/WHT	TB1 (RESOLVER & THERM CONN)
S8	REF	RED/WHT	
S7	SIN	YELLOW	
S6	COS	RED	
S5	COS GND	BLACK	
S4	SIN GND	BLUE	
S3	THERM	BLACK	
S2	THERM	BLACK	
S1	RES SHLD	GRN/YEL	

* USE ONLY WITH BRAKE OPTION

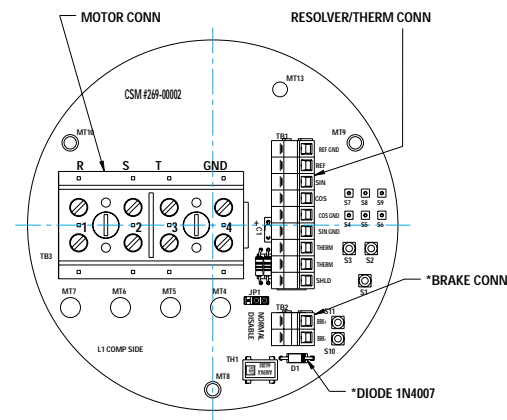

6" Motor with Encoder Feedback

Option 1

Motor Connector 270-00017 (SG3102E-22-22P(027))

Pin	Function	Wire Color
A	ϕ R	RED
B	ϕ S	BLACK
C	ϕ T	BLUE
D	PE GND	GRN/YEL

Encoder Connector 270-00024 (PT02E-14-18P(027))

Pin	Function	Wire Color
T	GROUND	BLACK
K	+5VDC	RED
B	CH A	BLUE
C	CH A\	BLUE/BLK
N	CH B	GREEN
P	CH B\	GRN/BLK
M	CH Z	YELLOW
U	CH Z\	YEL/BLK
E	CH U	BROWN
R	CH U\	BRN/BLK
F	CH V	GRAY
S	CH V\	GRAY/BLK
G	CH W	WHITE
H	CH W\	WHT/BLK
D	GND/CABLE	SHLD
A	THERM	BLACK
L	THERM	BLACK
J	GND	GRN/YEL

Option 1 with brake

Encoder Brake Connector 270-00219 (PT02E-16-23P(027))

Pin	Function	Wire Color
T	GROUND	BLACK
K	+5VDC	RED
B	CH A	BLUE
C	CH A\	BLUE/BLK
N	CH B	GREEN
P	CH B\	GRN/BLK
M	CH Z	YELLOW
U	CH Z\	YEL/BLK
E	CH U	BROWN
R	CH U\	BRN/BLK
F	CH V	GRAY
S	CH V\	GRAY/BLK
G	CH W	WHITE
H	CH W\	WHT/BLK
D	GND/CABLE	SHLD
A	THERM	BLACK
L	THERM	BLACK
J	GND	GRN/YEL
V	BRK (+)	DIODE
W	BRK (-)	1N4007
X	BRK SHLD	-
Y	-	-
Z	-	-

Option 2

Motor Connector 270-00325 (CEGA258NN0000001000)

Pin	Function	Wire Color
U	ϕ R(U1)	RED
PE	PE GND	GRN/YEL
W	ϕ S(W1)	BLACK
V	ϕ T(V1)	BLUE
*+	BRK (+)	DIODE
*-	BRK (-)	1N4007
1	THERM	BLACK
2	THERM	BLACK

* USE ONLY WITH BRAKE OPTION

Motor Connector 270-00257 (AEGA052NN00000013000)

Pin	Function	Wire Color
1	GND(OV)	BLACK
2	CH A\ (A)	BLUE/BLK
3	CH A (A)	BLUE
4	CH B (B)	GREEN
5	CH B\ (B)	GRN/BLK
6	CH Z (Z)	YELLOW
7	CH Z\ (Z)	YEL/BLK
8	+5V(+5V)	RED
9	-	-
10	CH U (RLG U)	BROWN
11	CH V (RLG V)	GRAY
12	CH W (RLG W)	WHITE

Option 3-Consult Factory