

# ACCU ELECTRIC MOTORS INC

USA: (888) 932-9183

CANADA: (905) 829-2505

- ✓ Over 100 years cumulative experience
- ✓ 24 hour rush turnaround / technical support service
- ✓ Established in 1993



The leading independent repairer of servo motors and drives in North America.

Visit us on the web:

[www.servo-repair.com](http://www.servo-repair.com)

[www.servorepair.ca](http://www.servorepair.ca)

[www.ferrocontrol.com](http://www.ferrocontrol.com)

[www.sandvikrepair.com](http://www.sandvikrepair.com)

[www.accuelectric.com](http://www.accuelectric.com)

**Scroll down to view your document!**

For 24/7 repair services :

USA: 1 (888) 932 - 9183

Canada: 1 (905) 829 -2505

Emergency After hours: 1 (416) 624 0386

Servicing USA and Canada



## **MOTION TECHNOLOGY DIVISION**

110 Fordham Road  
Wilmington, MA 01887  
(978) 988-9800  
Fax (978) 988-9940

Part# MA6410  
List Price \$25 U.S.  
October, 1998  
Rev E

# **M A 6 4 1 0**

# **6 4 1 0 D r i v e**

## **Installation & Hardware Reference Manual**



---

This document is copyrighted by Pacific Scientific Company. It is supplied to the user with the understanding that it will not be reproduced, duplicated, or disclosed in whole or in part without the express written permission of Pacific Scientific Company.



---

## WARRANTY AND LIMITATION OF LIABILITY

Includes software provided by Pacific Scientific

Pacific Scientific warrants its motors and controllers (“Product(s)”) to the original purchaser (the “Customer”), and in the case of original equipment manufacturers or distributors, to their original consumer (the “Customer”) to be free from defects in material and workmanship and to be made in accordance with Customer’s specifications which have been accepted in writing by Pacific Scientific. In no event, however, shall Pacific Scientific be liable or have any responsibility under such warranty if the Products have been improperly stored, installed, used or maintained, or if customer has permitted any unauthorized modifications, adjustments, and/or repairs to such Products. Pacific Scientific’s obligation hereunder is limited solely to repairing or replacing (at its option), at its factory any Products, or parts thereof, which prove to Pacific Scientific’s satisfaction to be defective as a result of defective materials or workmanship, in accordance with Pacific Scientific’s stated warranty, provided, however, that written notice of claimed defects shall have been given to Pacific Scientific within two (2) years after the date of the product date code that is affixed to the product, and within thirty (30) days from the date any such defect is first discovered. The products or parts claimed to be defective must be returned to Pacific Scientific, transportation prepaid by Customer, with written specifications of the claimed defect. Evidence acceptable to Pacific Scientific must be furnished that the claimed defects were not caused by misuse, abuse, or neglect by anyone other than Pacific Scientific.

Pacific Scientific also warrants that each of the Pacific Scientific Motion Control Software Programs (“Program(s)”) will, when delivered, conform to the specifications therefore set forth in Pacific Scientific’s specifications manual. Customer, however, acknowledges that these Programs are of such complexity and that the Programs are used in such diverse equipment and operating environments that defects unknown to Pacific Scientific may be discovered only after the Programs have been used by Customer. Customer agrees that as Pacific Scientific’s sole liability, and as Customer’s sole remedy, Pacific Scientific will correct documented failures of the Programs to conform to Pacific Scientific’s specifications manual. **PACIFIC SCIENTIFIC DOES NOT SEPARATELY WARRANT THE RESULTS OF ANY SUCH CORRECTION OR WARRANT THAT ANY OR ALL FAILURES OR ERRORS WILL BE CORRECTED OR WARRANT THAT THE FUNCTIONS CONTAINED IN PACIFIC SCIENTIFIC’S PROGRAMS WILL MEET CUSTOMER’S REQUIREMENTS OR WILL OPERATE IN THE COMBINATIONS SELECTED BY CUSTOMER.** This warranty for Programs is contingent upon proper use of the Programs and shall not apply to defects or failure due to: (i) accident, neglect, or misuse; (ii) failure of Customer’s equipment; (iii) the use of software or hardware not provided by Pacific Scientific; (iv) unusual stress caused by Customer’s equipment; or (v) any party other than Pacific Scientific who modifies, adjusts, repairs, adds to, deletes from or services the Programs. This warranty for Programs is valid for a period of ninety (90) days from the date Pacific Scientific first delivers the Programs to Customer.

---

THE FOREGOING WARRANTIES ARE IN LIEU OF ALL OTHER WARRANTIES (EXCEPT AS TO TITLE), WHETHER EXPRESSED OR IMPLIED, INCLUDING WITHOUT LIMITATION, ANY WARRANTY OF MERCHANTABILITY OR OF FITNESS FOR ANY PARTICULAR PURPOSE, AND ARE IN LIEU OF ALL OTHER OBLIGATIONS OR LIABILITIES ON THE PART OF PACIFIC SCIENTIFIC. PACIFIC SCIENTIFIC'S MAXIMUM LIABILITY WITH RESPECT TO THESE WARRANTIES, ARISING FROM ANY CAUSE WHATSOEVER, INCLUDING WITHOUT LIMITATION, BREACH OF CONTRACT, NEGLIGENCE, STRICT LIABILITY, TORT, WARRANTY, PATENT OR COPYRIGHT INFRINGEMENT, SHALL NOT EXCEED THE PRICE SPECIFIED OF THE PRODUCTS OR PROGRAMS GIVING RISE TO THE CLAIM, AND IN NO EVENT SHALL PACIFIC SCIENTIFIC BE LIABLE UNDER THESE WARRANTIES OR OTHERWISE, EVEN IF PACIFIC SCIENTIFIC HAS BEEN ADVISED OF THE POSSIBILITY OF SUCH DAMAGES, FOR SPECIAL, INCIDENTAL, OR CONSEQUENTIAL DAMAGES, INCLUDING WITHOUT LIMITATION, DAMAGE OR LOSS RESULTING FROM INABILITY TO USE THE PRODUCTS OR PROGRAMS, INCREASED OPERATING COSTS RESULTING FROM A LOSS OF THE PRODUCTS OR PROGRAMS, LOSS OF ANTICIPATED PROFITS, OR OTHER SPECIAL, INCIDENTAL, OR CONSEQUENTIAL DAMAGES, WHETHER SIMILAR OR DISSIMILAR, OF ANY NATURE ARISING OR RESULTING FROM THE PURCHASE, INSTALLATION, REMOVAL, REPAIR, OPERATION, USE OR BREAKDOWN OF THE PRODUCTS OR PROGRAMS, OR ANY OTHER CAUSE WHATSOEVER, INCLUDING NEGLIGENCE.

The foregoing shall also apply to Products, Programs, or parts for the same which have been repaired or replaced pursuant to such warranty, and within the period of time, in accordance with Pacific Scientific's date of warranty.

No person, including any agent, distributor, or representative of Pacific Scientific, is authorized to make any representation or warranty on behalf of Pacific Scientific concerning any Products or Programs manufactured by Pacific Scientific, except to refer purchasers to this warranty.

---

# Table of Contents

.....

<b>1 Overview of the 6410</b>	<b>1-1</b>
1.1 6410 Definition . . . . .	1-1
1.2 Other System Components . . . . .	1-4
1.3 How to Use this Manual . . . . .	1-5
1.4 Warranty . . . . .	1-5
<b>2 Installing the 6410</b>	<b>2-1</b>
2.1 Unpacking and Inspecting . . . . .	2-1
2.2 Installing and Using the 6410. . . . .	2-2
2.3 Selecting Other System Components . . . . .	2-3
2.4 Mounting the 6410 Unit . . . . .	2-4
2.5 Connecting to the 6410 . . . . .	2-7
2.5.1 J3 Motor Connections . . . . .	2-9
2.5.2 J2 Power Connector. . . . .	2-17
2.5.3 J1 Signal Interface Connector . . . . .	2-20
<b>3 Powering Up the 6410 Drive</b>	<b>3-1</b>
3.1 Setting Switch S1 & Jumper J6. . . . .	3-1
3.1.1 Step Size . . . . .	3-3
3.1.2 Digital Electronic Damping Control . . . . .	3-4
3.1.3 Idle Current Reduction . . . . .	3-5
3.1.4 Setting Motor Current . . . . .	3-6
3.1.5 Enable Sense Control . . . . .	3-6
3.1.6 Step Bandwidth Adjustment . . . . .	3-6
3.2 Testing the Installation . . . . .	3-7
<b>4 Maintaining/Troubleshooting</b>	<b>4-1</b>
4.1 Maintaining the 6410 Drive. . . . .	4-1
4.2 Troubleshooting the 6410 Drive . . . . .	4-1



---

<b>Appendix A Specifications</b>	<b>A-1</b>
<b>Appendix B Ordering Information</b>	<b>B-1</b>
<b>Appendix C Power Supply Considerations</b>	<b>C-1</b>
<b>Appendix D CE Installation</b>	<b>D-1</b>
<b>Index</b>	

---

# 1 Overview of the 6410

---

**In this chapter** This chapter introduces the 6410 stepper drive. Topics covered are:

- 6410 definition
- Other system components
- System diagram
- How to use this manual
- Warranty information

## 1.1 6410 Definition

---

### Overview

The Pacific Scientific 6410 converts step and direction inputs into motor winding currents to control a two-phase stepper motor. Principal features include microstepping and mid-band instability compensation for high resolution and smooth operation through both the low speed and mid-band resonance regions.

The output current of the 6410 is dip switch selectable from 5A rms (7.1 A peak in microstep mode) to 0.625A rms (0.88A peak in microstep mode).

The drive supplies regulated phase currents for supply voltages between 24 and 75 Vdc. It is designed for use with Pacific Scientific's line of hybrid stepping motors and will work with either the standard line or the enhanced performance line.

**Note:** *The motor winding must be compatible with the output current of the drive.*

---

## Drive features

**Bipolar chopper drive** - patented 4-phase PWM (pulse width modulation) chopping electronically controls the motor winding currents at 20 KHz frequency. This combines the best of recirculating and non-recirculating current regulation producing high back EMF rejection with low chopping ripple current. Benefits include: reduced heat dissipation, low electric noise and improved current control during motor breaking.

**Microstepping** - switch selectable: full, 1/2, 1/5, 1/10, 1/25, 1/50, 1/125, and 1/250 step capability with decimal jumper installed and 1/2, 1/4, 1/8, 1/16, 1/32, 1/64, 1/128, and 1/256 with decimal jumper removed.

**Digital Electronic Damping** - patented circuit eliminates torque and/or motor stalling through mid-speed region that is inherent in all open loop stepper applications.

**Short circuit protection circuitry** - disables the drive if a short circuit occurs on the motor outputs. The drive must be power cycled to clear fault.

**MOSFET power devices** - allows chopper frequency of approximately 20 kHz, eliminating acoustical noise often associated with choppers.

**Optically isolated signal interface connection** - optical isolation is provided on the step, direction and enable inputs in addition to the enabled output. The use of optical isolation increases the options available for system grounding. The source commanding the step and direction lines is not tied directly to the motor power supply ground, allowing the system ground point for these signals to be made external to the unit.

**UL Recognized - 508C (Type R)** - File Number E-137798. This also complies with CSA Standard for Process Control Equipment, C22.2 No. 142-M1987.

---

**User adjustments**

using DIP switch S1

**Motor current** - sets the motor phase current to 5.0, 4.375, 3.75, 3.125, 2.5, 1.875, 1.25, or 0.625 A rms.

**Step size** - sets the amount of shaft rotation per step (with the decimal jumper installed). The settings are full, half, 1/5, 1/10, 1/25, 1/50, 1/125, and 1/250 steps per (micro)step. This corresponds to 200, 400, 1000, 2000, 5000, 10,000, 25,000, and 50,000 (micro)steps per revolution with a standard 1.8° motor. With the decimal jumper removed, the settings are 1/2, 1/4, 1/8, 1/16, 1/32, 1/64, 1/128, and 1/256 steps per (micro) step. This corresponds to 400, 800, 1600, 3200, 6400, 12,800, 25,600, and 51,200 (micro) steps per revolution.

**Digital Electronic Damping control** - enables this patented feature which eliminates loss of torque and possible motor stalling conditions when operating at mid-range speeds. This instability is a phenomenon of the electronic, magnetic and mechanical characteristics of a stepping motor system. The compensation circuit damps mid-range oscillations by advancing or delaying switching of the output current relative to the incoming pulse train.

**Idle current reduction (ICR)** - enables or disables idle current reduction which reduces motor winding current by 50% of its rated value during motor dwell periods. ICR begins 0.1 second after the last input step pulse occurs. This delay can also be set to 0.05 seconds or 1 second using a plug-on jumper.

**Note:** *The current will return to 100% at the next step pulse.*

using plug-on jumpers

**Step filter** - when enabled (jumper installed) rejects noise pulses on step input less than 500ns wide. Useful if maximum step rate is 500 KHz.

**Enable sense** - allows the polarity of the enable input to be reversed. With the jumper installed, the enable input opto-isolator must be driven to enable drive. With the jumper removed, enable input opto-isolator must be driven to disable.

---

### **Typical applications**

Typical applications for 6410 include:

- X-Y tables and slides
- Packaging machinery
- Robotics
- Specialty machinery
- Index feed of material
- Labeling machines

## **1.2 Other System Components**

---

### **Overview**

The other components that, along with the drive, comprise a complete motor control system are:

- Indexer or step source
- Single power supply (24-75 volts)
- Motor

Installation guidelines for these components are described in Chapter 2, "Installing the 6410 Stepper Motor Drive."

**System Diagram** The following diagram shows an installation of the drive in a typical system.

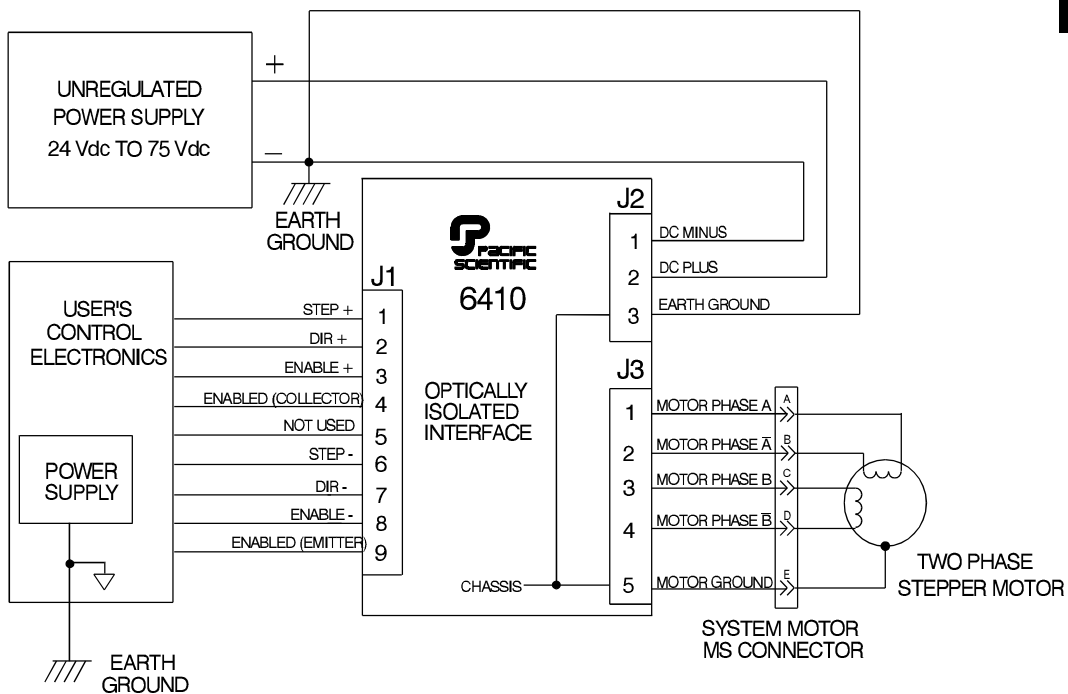

**Note:** Your installation may vary from this configuration.

### 1.3 How to Use this Manual

This manual contains information and procedures to install, setup, and troubleshoot the 6410 stepper motor drive.

The most effective way to use this manual is to follow the installation and power up instructions contained in Chapter 2 and Chapter 3.

---

## 1.4 Warranty

---

The Pacific Scientific 6410 drives have a **two year warranty** against defects in material and assembly. Products that have been modified by the customer, physically mishandled, or otherwise abused through miswiring, incorrect switch settings, and so on, are exempt from the warranty plan.

---

## 2 Installing the 6410

---

**In this chapter** This chapter explains how to install the 6410 stepper motor drive. Topics covered are:

- Unpacking and inspecting the 6410
- Installing and using the 6410 unit safely
- Selecting other system components
- Mounting the 6410 in your installation
- Connecting input/output cables

### 2.1 Unpacking and Inspecting

---

**Unpacking procedure**

1. Remove the 6410 from the shipping carton. Make sure all packing materials are removed from the unit.
2. Check the items against the packing list. A label located inside the chassis of the unit identifies the unit by model number, serial number, and date code.

---

**Inspection procedure**

Inspect the unit for any physical damage that may have been sustained during shipment.

If you find damage, either concealed or obvious, contact your buyer to make a claim with the shipper. Do this within 10 days of receipt of the unit.

---

**Storing the unit**

After inspection, store the controller in a clean, dry, place. The storage temperature must be between -55 degrees C and 70 degrees C. To prevent damage during storage, replace the unit in the original shipping carton.



---

## 2.2 Installing and Using the 6410 Unit Safely

---

### Your responsibility

As the user or person applying this unit, you are responsible for determining the suitability of this product for any application you intend. In no event will Pacific Scientific Company be responsible or liable for indirect or consequential damage resulting from the misuse of this product.

**Note:** *Read this manual completely to effectively and safely operate the 6410 unit.*



### Safety guidelines

---

#### **Warning**

***The circuits in the 6410 drive are a potential source of severe electrical shock. Follow the safety guidelines to avoid shock.***

To avoid possible personal injury whenever you are working with the 6410 unit:

- Do not operate the drive without the motor case tied to earth ground.  
**Note:** *This is normally done by connecting the motor's case to J3-5 of the 6410 and connecting J2-3 of the 6410 to earth ground.*
- Do not make any connections to the internal circuitry. The input and output signals are the only safe connection points.
- Always remove power before making or removing connections from the unit.
- Be careful of the J3 motor terminals when disconnected from the motor. With the motor disconnected and power applied to the drive, these terminals have high voltage present, even with the motor disconnected.
- Do not use the ENABLE input as a safety shutdown. Always remove power to the drive for a safety shutdown.

---

## 2.3 Selecting Other System Components

---

### Selecting an indexer

The 6410 drive requires STEP and DIRECTION inputs. Select an indexer that provides, as a minimum, these commands. A compatible indexer will provide the capability to drive the input circuits shown in Section 2.5.3. For most applications that operate at speeds above 300 rpm, an indexer that can ramp the step frequency is required.

---

### Selecting a motor

The 6410 is designed for use with Pacific Scientific's line of hybrid stepper motors or most other 2 phase stepper motors. The drive works with either the standard line or the enhanced high performance line of stepper motors. The motor winding current rating must be compatible with the output current of the drive package.

Refer to the Torque/Speed Curves in the Pacific Scientific "Motion Control Solutions Catalog" or contact your local Pacific Scientific distributor for sizing and motor compatibility assistance.

---

### Selecting power supply

A single power supply is required to operate the 6410 unit.

**Note:** *In multi-axis applications, it is preferable to run each power connection from supply to drive and not daisy-chain the power connections.*

The power supply can vary from +24 to 75 Volts maximum at a maximum current of 5 amps. It does not have to be a regulated supply.

**Note:** *The supply voltage cannot exceed 75 volts.*

#### **IMPORTANT NOTE**

**Important information about the power supply is outlined in Section 2.5.2 and Appendix C. Read these sections carefully before applying power to the drive.**



---

## 2.4 Mounting the 6410 Unit

---

### Cooling plate mounting

For optimal thermal performance and minimum panel usage, mount the 6410 bookcase style to a cooling plate (typically an Aluminum plate or heatsink with enough thickness and surface area to maintain the 6410's chassis below 60°C ) using two M4 or 6-32 screws inserted through the mounting slots on the back of the unit. Use a thermal pad or grease if surface is irregular. The maximum temperature of the 6410's back plate must be held below 60°C. The graph of 6410 power dissipation vs. current setting shown below may be used to design the cooling plate or direct measurements can be taken during normal operations and adjustments made to plate area or airflow over the plate if necessary. Make sure that any difference between the ambient temperature during the measurement and worst case ambient temperature is accounted for. The 6410 can also be mounted with its side against the cooling plate using 4 M4 or 6-32 screws if mounting depth is of greater concern than panel area. The same thermal considerations apply as for back mounting.

### Power dissipation vs. current

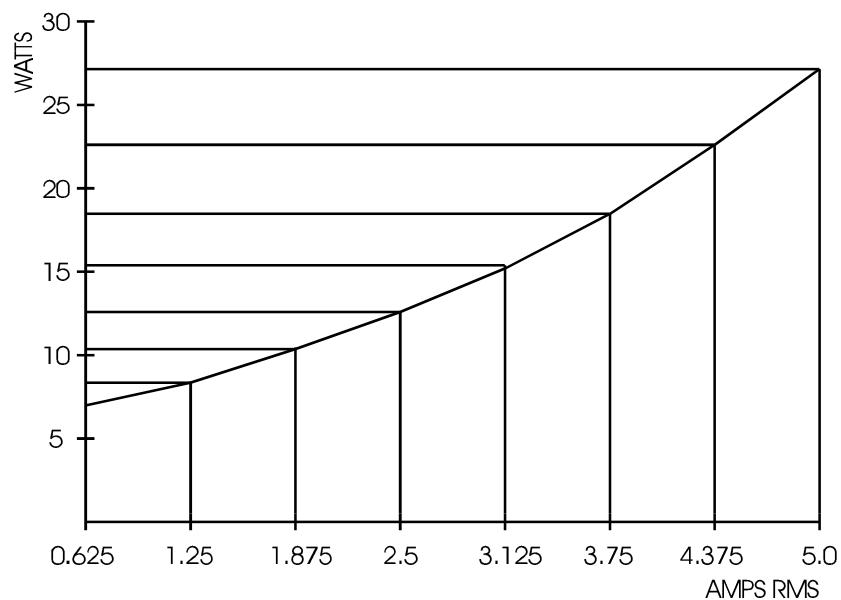

---

### Heatsink mounting

If a cooling plate is not provided, the optional heatsink available from Pacific Scientific can be mounted to the side of the 6410 and the combined unit mounted to a panel using the slots on the back of the 6410 as described above (bookcase mounting). With a minimum unobstructed space of four inches above and below the unit, and cooling accomplished solely through convection (no fan), the 6410 can be run at 5 Amps RMS maximum for ambient temperatures of 25°C or less and 2.5 Amps RMS maximum for ambient temperatures of 45°C or less. Using a fan to blow air past the heatsink will increase the allowable current significantly. It is always required that the 6410's chassis temperature not exceed 60°C. It is best to confirm this by direct measurement with a temperature probe during system operation. Any difference between the ambient temperature during the measurement and the worst case should be added to the measured chassis temperature. The resulting sum must be under 60°C.

### Panel mounting

If the 6410 is mounted to a panel with no cooling plate and no heat sink, a minimum unobstructed space of four inches above and below and one inch between the side plate and any other object must be provided. If cooling is accomplished solely through convection air flow (no fan), the unit can be run at 2.5 Amps RMS maximum if the ambient temperature is 25°C or less and 1.25 Amps RMS maximum if the ambient temperature is 45°C or less. Again, use of a fan to blow air past the side plate of the 6410 will increase the allowable current. The same considerations given above for the optional heatsink apply.

**Mounting dimensions**

When mounting the 6410, please refer to the dimensions below:

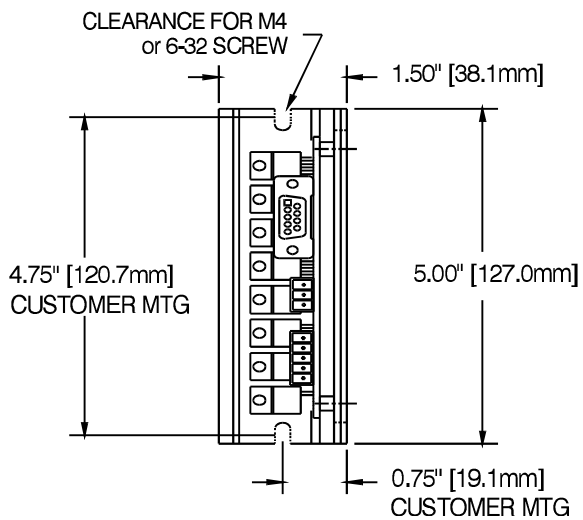
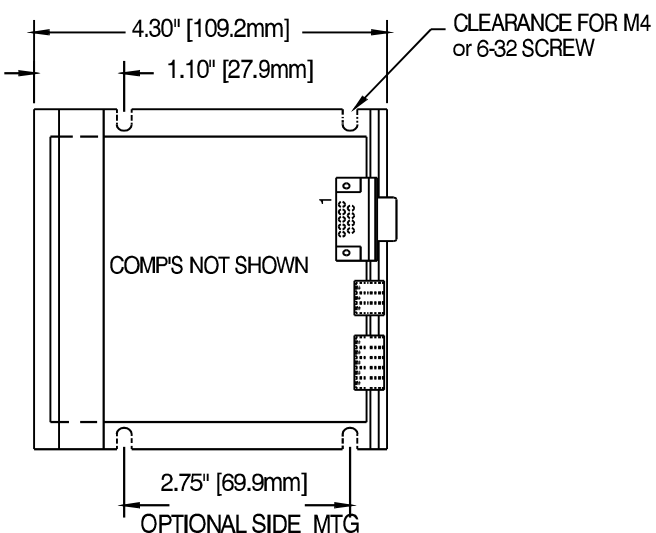

---

## Mounting guidelines

Your installation should meet the following guidelines:

- Vertical orientation for the unit.
- Flat, solid surface capable of supporting the approximate 1.0 lb. weight (0.5 kg. mass) of the unit.
- Free of excessive vibration or shock.
- Minimum unobstructed space of 4 inches (10 cm) above and below the unit.
- Maximum ambient temperature of 50° C and maximum 6410 chassis temperature of 60° C.

## 2.5 Connecting to the 6410

---

### Introduction

The three input/output (I/O) connectors are:

- J1 - Signal connector
- J2 - Power connector
- J3 - Motor connector

These inputs and outputs are shown on the following page.

**Connection diagram**

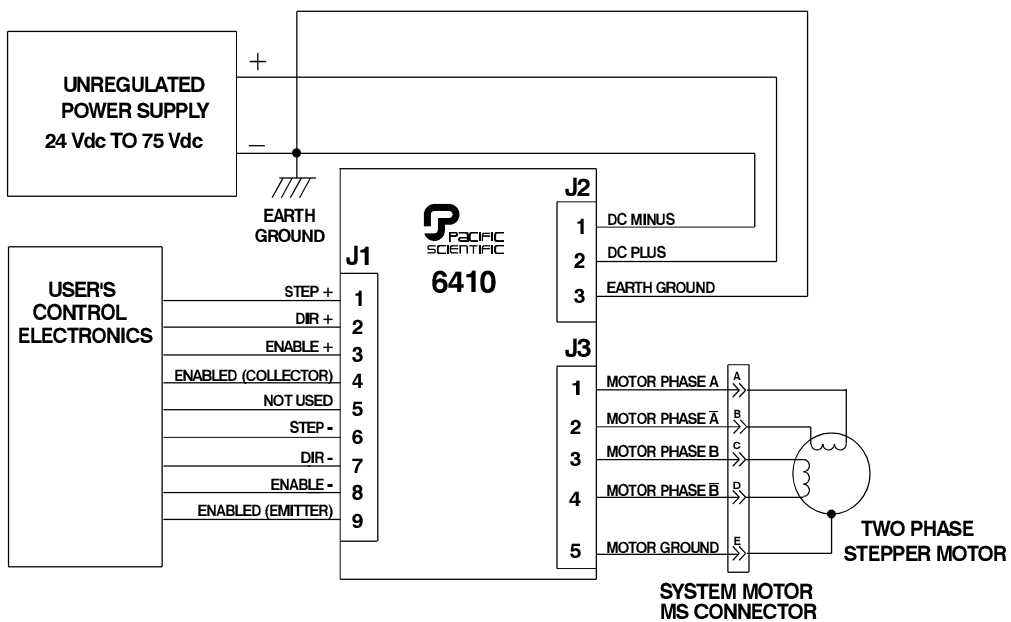

---

**Wiring is application specific**

Wiring sizes, wiring practices and grounding/shielding techniques described in the following section represent common wiring practices and should prove satisfactory in the majority of applications.



**Caution**

*Non-standard applications, local electrical codes, special operating conditions, and system configuration wiring needs take precedence over the information included here. Therefore, you may need to wire the drive differently than described here.*

**Noise pickup reduction**

Use shielded and twisted cabling for the signal and power cables as described below. This precaution reduces electrical noise.

**Shock hazard reduction**

Refer to section 2.2 for safety information that must be followed to reduce shock hazard.

---

## 2.5.1 J3 Motor Connections

**Introduction**

The J3 motor cable connects the controller to the motor windings and motor case. J3 utilizes a plug-in screw terminal/type connector to simplify assembly and allow quick connect and disconnect.

**Pacific Scientific cable**

Pacific Scientific makes cables that connect directly from J3 to our system motors. To order the cable from Pacific Scientific, use the order number SPC-xxx-6410, where “xxx” is the length, in feet (one-foot increments) up to 50 feet. For example, SPC-050 is a cable 50 feet long.



**Pacific Scientific cabling diagram** If you are using Pacific Scientific motor cable, with the mating connectors already attached, install as follows:

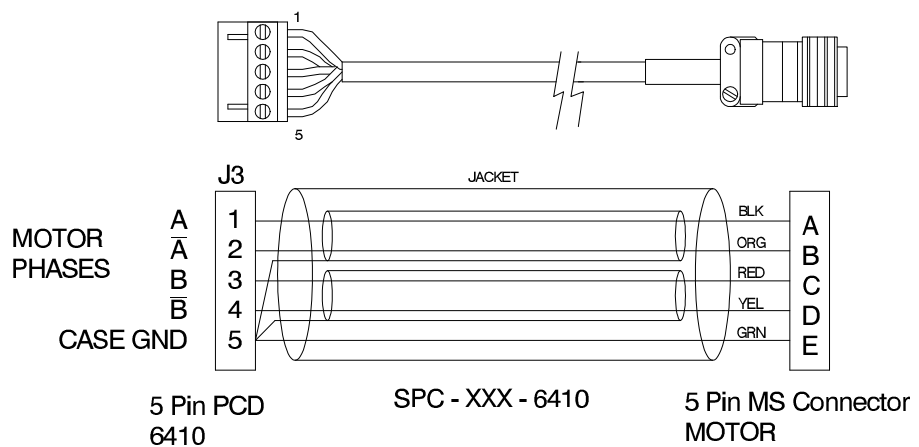

**Note:** All wires are #16 AWG.

---

**Making your own cable** To make your own motor cable, follow the guidelines given below for wiring to the J3 mating connector. Depending on your motor configuration, refer to the appropriate diagram at the end of this section to determine the motor connections required.

---

#### J3 connection table

Output	Pin	Explanation
Motor Phase A	J3-1	Motor Phase A excitation. Twisted Pair.
Motor Phase $\bar{A}$	J3-2	
Motor Phase B	J3-3	Motor Phase B excitation. Twisted Pair.
Motor Phase $\bar{B}$	J3-4	
Drive Case (Earth) Ground	J3-5	Connected to the motor case ground.

#### Mating connector

The J3 motor connector on the 6410 mates to a 5-pin PCD screw cable connector. The mating cable connector is type ELVP05100.

#### Cable requirements

The mating connector terminals will accept #16 to #28 AWG wire. However, use #16 AWG or heavier for motor phase excitations.

For the motor cable, use cable with two twisted pairs twisted at about 3 to 4 turns per inch (1 to 1.5 turns per centimeter) for the motor phase excitations and a fifth wire for the case ground. As an option, the cable may be shielded to reduce radiated noise. A single shield can be used around both phase excitations and the ground wire or each phase excitation (twisted pair) can be individually shielded as in the Pacific Scientific cables. Connect shields to pin 5 of the mating connector.

---

### Cabling diagram - J3 motor

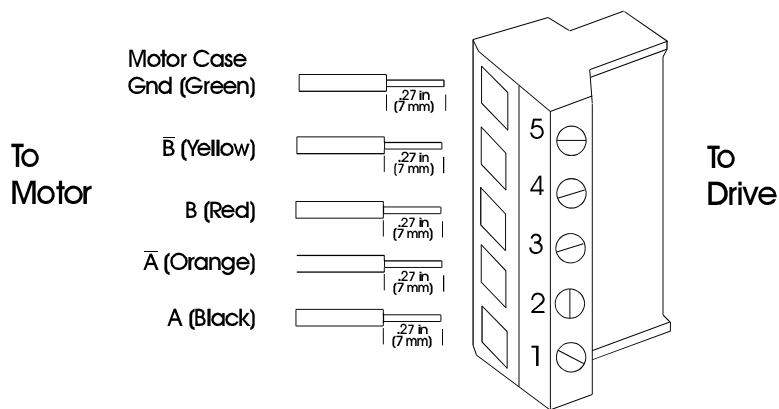

**Note:** The colors in the diagram follow the Pacific Scientific stepper motor cable color code.

---

### Procedure

1. Strip the wires to 0.27 in (7mm).
2. Attach wires to connector as indicated in the diagram.

**Note:** Make sure the screws on the PCD connector are tightened down firmly on the wiring.

### Caution

**Do not solder the tips of the cables before insertion into the connector. Solder can contract and cause a loose connection over time.**



## Flying Lead Connection

The figure below shows the connections required between the 6410 connector J3 and Pacific Scientific motors having flying leads. Connections are shown for 4 lead motors, 8 lead motors with paralleled windings, and 8 lead motors with series windings. Wire nuts may be used for the winding connections at the motor end.

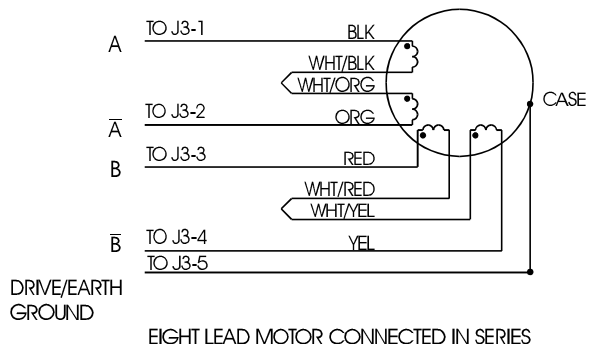
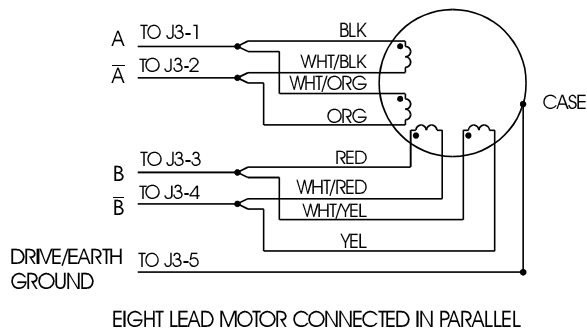
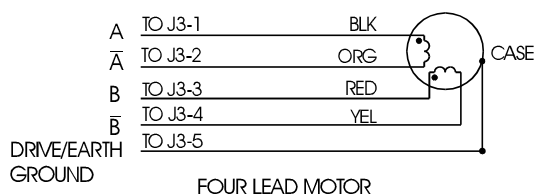

Installation

### Terminal board connections

The figure below shows the connections required between the 6410 connector J3 and Pacific Scientific stepper motors having a terminal board in the rear end bell. Connections are shown for 4 lead motors, 8 lead motors with paralleled windings, and 8 lead motors with series windings.

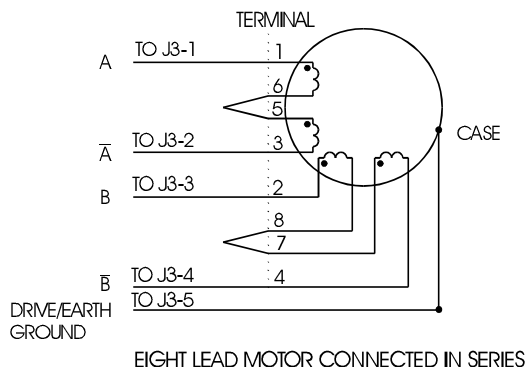
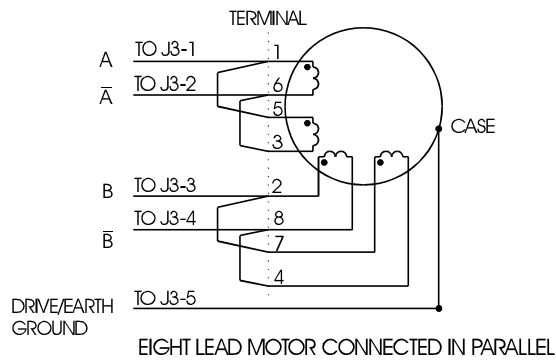
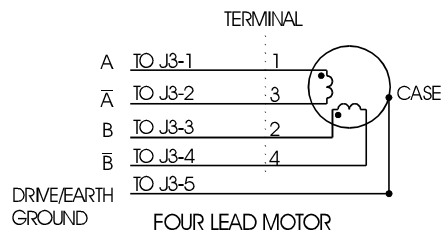

## MS connectors connection

The figure below shows the connections required between the 6410 J3 connector and Pacific Scientific stepper motors having MS connectors. Connections are shown for 4 lead motors, 8 lead motors with paralleled windings, and 8 lead motors with series windings.

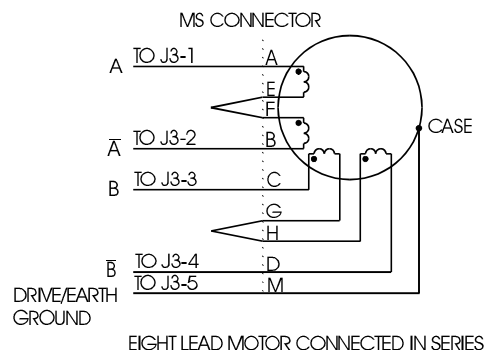
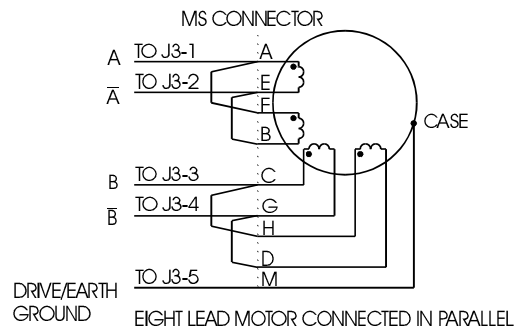
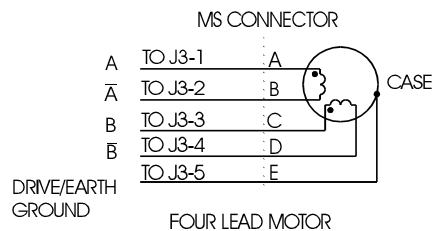

Installation

**Power Max motor connections**

The figure below shows the connections required between the 6410 and Pacific Scientific Power Max Motors. Power Max motors have an eight pin connector and can be configured with either parallel or series windings.

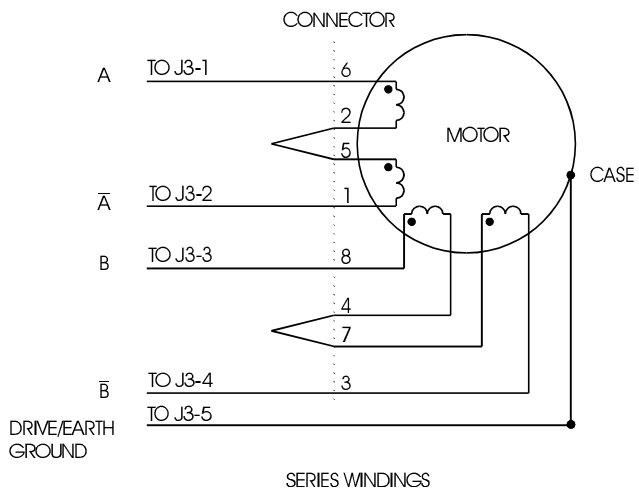
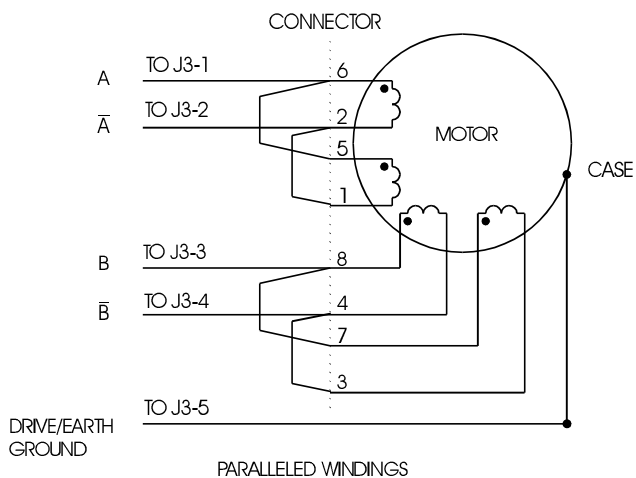

## 2.5.2 J2 Power Connector

### Introduction

The J2 power cable connects the 6410 to the power supply. Please refer to Appendix C for additional information on power supply considerations.

### J2 power table

Input	Pin	Explanation
DC -	J2-1	+24 to +75 Vdc max at 5 amps
DC +	J2-2	The negative side of the power supply (connected to DC-) should be connected to Earth ground. No connection is made within the 6410 between J2-1 and J2-3.
Earth Ground	J2-3	Connected to 6410 Case and J3-5 (Motor Ground)

### Power connection

Connections between the 6410 and power supply are shown in the diagram on the following page. A simple non-regulated supply is used for this example. DC+ and DC- should be run from the power supply's capacitor to the 6410 as a twisted pair no longer than 3 feet in length (shielding, with the shield connected to earth ground, can reduce noise emissions). A Buss MDA 10 A, slow-blow fuse (or equivalent) should be included in the power supply between the rectifier and capacitor as shown.

#### **IMPORTANT NOTE**

*It is extremely important that the supply voltage never exceed 75 volts even on a transient basis. This is one of the most common causes of drive failures. Wiring inductance between the 6410 power input and the external capacitor is significant because a PWM chopper drive requires pulse currents. Therefore, it is extremely important that the two be connected by a twisted pair no longer than three feet in length.*





**Connection diagram**

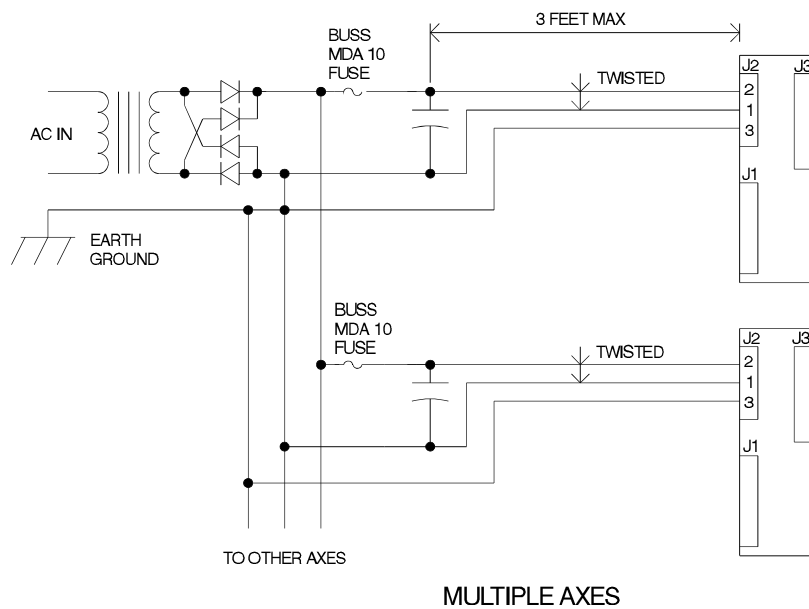
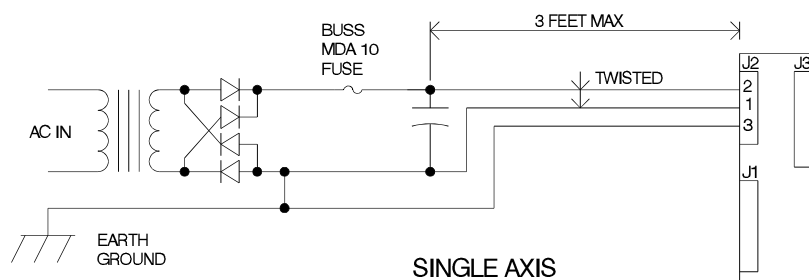

**Cable requirements**

Use #16 AWG for the power supply cable. Use cable twisted at about 3 to 4 turns per inch (1 to 1.5 turns per centimeter).

---

Cable diagram -  
J2 power cable

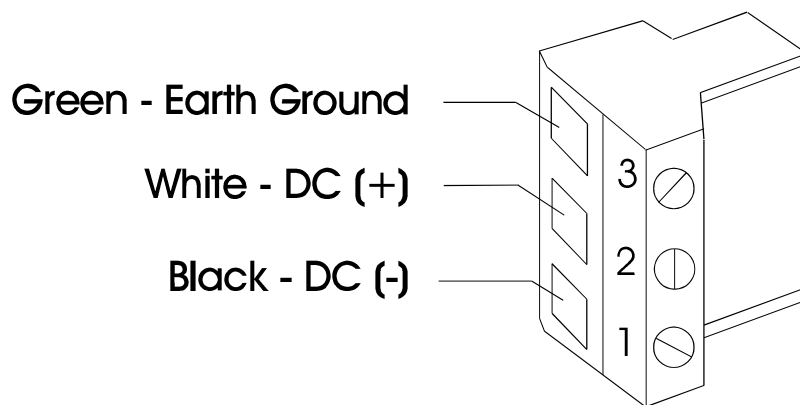

Installation

---

**Procedure**

1. Strip the wires 0.27 inch (7mm).
2. Attach the wires to the connector as indicated in the diagram.

**Note:** Make sure the screws on the PCD connector are tightened down firmly on the wiring.



**Caution**

**Do not solder the tips of the cables going into the PCD connector. This can result in a loose connection.**

---

### 2.5.3 J1 Signal Interface Connection

**Introduction**

The J1 signal interface accepts step, direction and enable signals from an indexer or other source and outputs an enabled signal which indicates the 6410 is applying current to the motor windings.

---

**J1 signal table****Note:** *All inputs and outputs are optically isolated.*

<b>Input/Output</b>	<b>Pin</b>	<b>Explanation</b>
<b>STEP +</b>	J1-1	Input used to command motor rotation. See figure at the end of the table for circuit and timing information.
<b>DIR +</b>	J1-2	Input that determines the direction of motor rotation. If standard motor wiring is followed, the motor will turn clockwise if the opto current is zero. The sense of the DIR + input can be reversed by reversing the connection of either (but not both) motor phase connectors (i.e. switching A & $\bar{A}$ OR B & $\bar{B}$ ). Refer to the figure at the end of the table for timing and circuit information.
<b>ENABLE +</b>	J1-3	Input used to enable or disable the 6410's power stage. With the J6 5-6 jumper out (factory default) the power stage is enabled if the opto current is zero and disabled if the opto is driven. Inserting the jumper reverses this functionality. See figure at the end of the table for circuit information. There is a delay of approximately 500 $\mu$ s after enabling the drive and the power stage becoming active.
<b>Enabled Collector</b>	J1-4	Output. Collector of transistor that is on when the 6410's power stage is active. See figure at the end of the table for circuit information.
	J1-5	Not used.
<b>STEP -</b>	J1-6	Input used to command motor rotation. See figure at the end of the table for circuit and timing information.

Table cont'd

Input/Output	Pin	Explanation
<b>DIR -</b>	J1-7	Input that determines the direction of motor rotation. If standard motor wiring is followed, the motor will turn clockwise if the opto current is zero. The sense of the DIR + input can be reversed by reversing the connection of either (but not both) motor phase connectors (i.e. switching A & $\bar{A}$ <b>OR</b> B & $\bar{B}$ ). Refer to the figure at the end of the table for timing and circuit information.
<b>ENABLE -</b>	J1-8	Input used to enable or disable the 6410's power stage. With the J6 5-6 jumper out (factory default) the power stage is enabled if the opto current is zero and disabled if the opto is driven. Inserting the jumper reverses this functionality. See figure at the end of the table for circuit information. There is a delay of approximately 500 $\mu$ s after enabling the drive and the power stage becoming active.
<b>Enabled Emitter</b>	J1-9	Output. Emitter of transistor that is on when the 6410's power stage is active. See figure at the end of the table for timing and circuit information.

### Typical interface

The figure on the following page shows a typical interface between the user's electronics and the 6410. The TTL gates should have totem pole outputs and be capable of sinking at least 10.0 mA at 0.4 volts.

**Interface diagram**

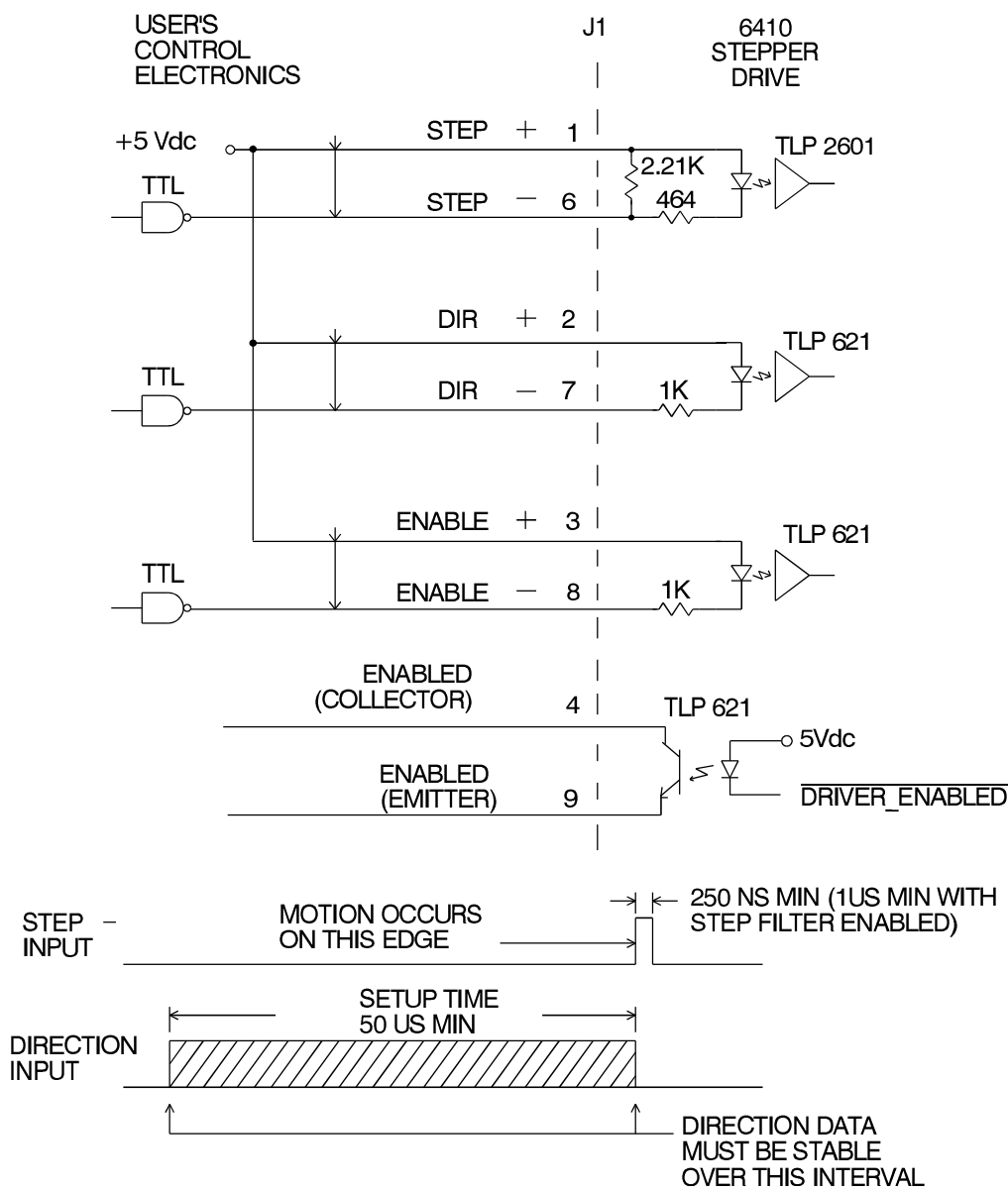

## Higher voltage interface

Voltages up to 30 volts can be used for the opto power input to the 6410 drive. However, a resistor must be put in series with the command inputs as shown below. Values for several common supply voltages are given in the following table.

If the drives have open collector outputs, pull up resistors (R3) should be added as shown. A typical value of R3 is 2.7K.

Opto Supply to 6410	R1	R2
+12 Vdc	1 Kohm	1.5 K
+15 Vdc	1.5 Kohm	2.2 K
+30 Vdc	3.3 Kohms	6.8 K

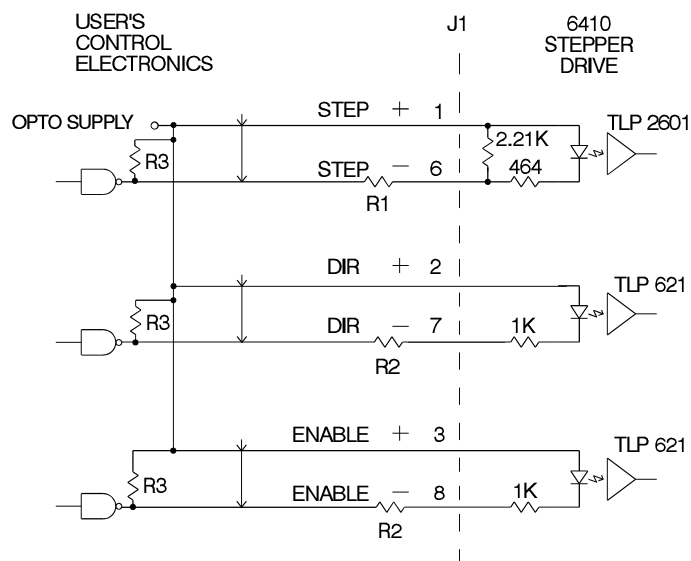

Installation

---

**Mating  
connector**

The J1 signal interface connector is 9 contact female D connector.  
The mating cable connector is an ITT Cannon DE-9P with ITT  
Cannon DE110963 Hood and D20419 Clamp Kit.

---

## 3 Powering Up the 6410 Drive

---

**In this chapter** This chapter explains how to power up the 6410 drive after installation. Topics covered are:

- Setting up functions using switch S1 and Jumper J6
- Testing the installation

This section is intended to familiarize the 6410 user with the hardware adjustments and settings required to power up and operate the 6410 drive.

### 3.1 Setting Switch S1 & Jumper J6

---

**Introduction** DIP switch S1 and Jumper J6 set the following:

- Step size
- Motor current level
- Digital electronic damping ON/OFF
- Idle current reduction
- Enable sense
- Step filter response time

Powering Up



## Location of S1

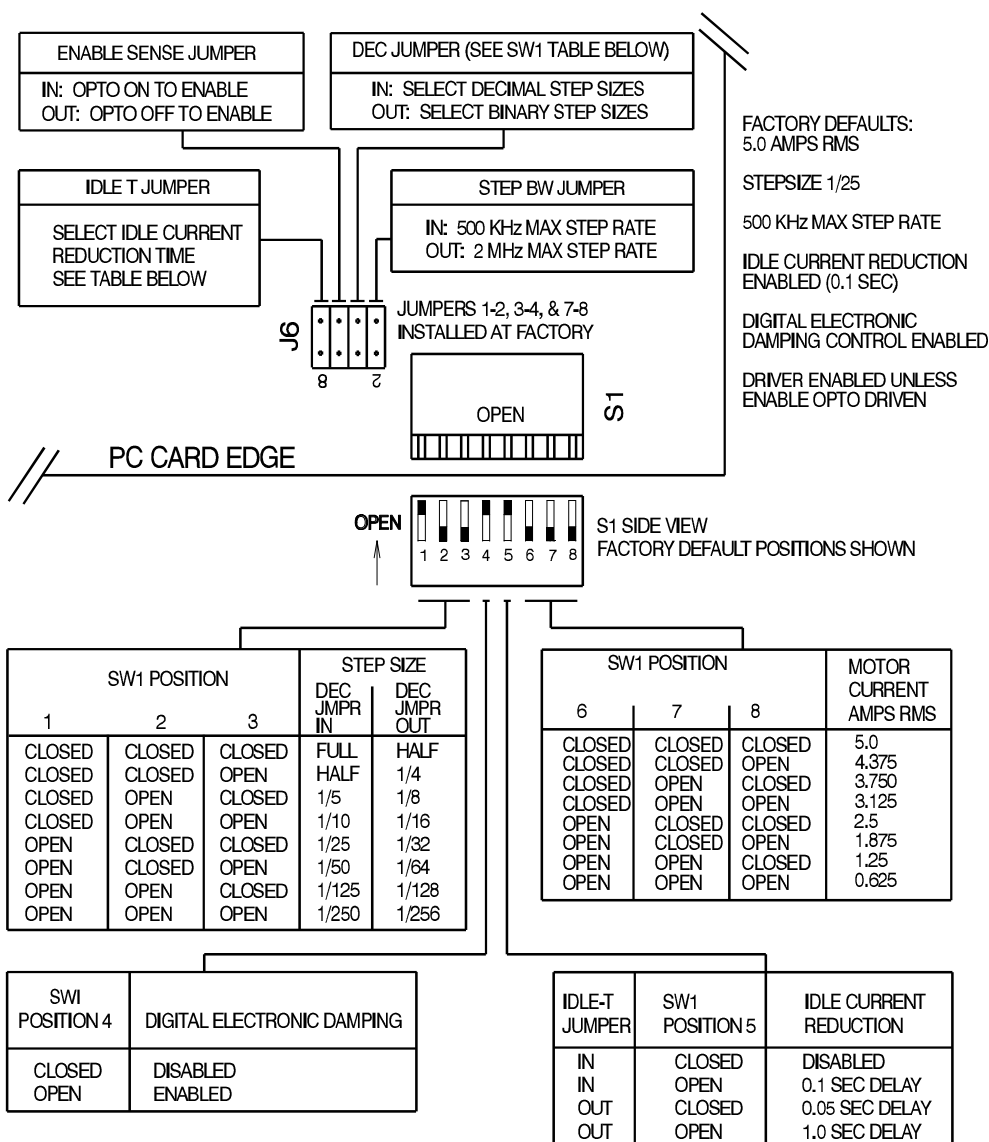

---

### 3.1.1 Step Size

---

#### Definition

The step size sets the amount of rotation per input step. Fifteen step sizes are available using Jumper J6 position 3-4 and DIP switch S1 positions 1-3 as shown. For all Pacific Scientific stepper motors and all 1.8° step motors, step size can be converted to steps per rotation using the following table:

Decimal		Binary	
Full	200	Half	400
Half	400	1/4	800
1/5	1,000	1/8	1,600
1/10	2,000	1/16	3,200
1/25	5,000	1/32	6,400
1/50	10,000	1/64	12,800
1/125	25,000	1/128	25,600
1/250	50,000	1/256	51,200

Powering Up

---

#### Benefits

Selecting a microstep size of 1/4 or smaller results in:

- higher resolution
- smoother low speed operation
- ability to operate in low-speed resonance regions

---

### 3.1.2 Digital Electronic Damping Control

---

**Definition**

Mid-speed instability and the resulting loss of torque occurs in any step motor/drive system due to the motor back EMF modulating the motor winding currents at certain speeds. Mid-speed instability can be explained as a region of potential instability that occurs as a result of the electronic, magnetic, and mechanical characteristics of any stepping motor system. The circuitry used to control this phenomenon does so by advancing or delaying the switching of the output current with respect to the incoming pulse train. This should be taken into account if the user is attempting to employ pulse placement techniques.

Enable the digital electronic damping function by placing DIP switch S1 position 4 in the open position as shown. This is the default position and should be used for most applications if your application is affected by loss of torque at mid-range speeds. If pulse placement techniques are being used, disable the digital electronic damping function by placing DIP switch S1 position 4 in the open position.

---

**Benefit**

This feature controls torque loss at mid-range speeds. When enabled, the motor maintains torque at mid-range operation, provided the torque load does not exceed motor torque ratings.

---

### 3.1.3 Idle Current Reduction

---

**Definition**

The Idle Current Reduction (ICR) function reduces the phase current at times when no motion is commanded. Motor current is reduced when no step commands are received for a given time. This time can be set to 0.05 seconds, 0.1 seconds or 1.0 second. Current to both motor windings is reduced by one-half.

The ICR function can be enabled/disabled and the time delay between the last step command and current reduction can be set to 50 ms, 0.1 seconds, or 1.0 second using DIP switch S1 position 5 and Jumper J6 position 7-8. With the jumper installed (factory default), ICR is disabled when DIP Switch S1 position 5 is in the closed position and enabled with a delay of 0.1 second (current is reduced by 50% when no step command is received for 0.1 second when the switch is open. With the jumper removed, ICR is enabled and the delay can be set to 0.05 second or 1.0 second by placing DIP Switch S1 position 5 in the closed or open position respectively.

**Note:** *When ICR is active, both the holding torque generated by the motor and the motor stiffness around the holding position are reduced by approximately 50%.*

---

**Benefits**

The ICR function:

- Reduces motor and drive heating during stand-by operation

---

### 3.1.4 Setting Motor Current

---

Motor current can be set using DIP Switch S1 positions 6, 7, and 8 as shown. Current should be compatible with motor current ratings.

**Note:** *Power dissipation in the 6410 drive increases as the output current is increased, so that more cooling is required at high motor currents.*

### 3.1.5 Enable Sense Control

---

The polarity of the enable input can be changed using Jumper J6 position 5-6. With the jumper removed (factory default), the drive is enabled when the enable input is not driven and disabled when driven (current flows in enable opto). This allows the 6410 to be used with no connection to the enable input. With the J6 5-6 jumper installed, the enable input must be driven (current in opto) for the 6410 power stage to be enabled.

### 3.1.6 Step Bandwidth Adjustment

---

A digital filter can be enabled which reduces susceptibility to noise on the step input at the expense of a lower limit on maximum step frequency. With Jumper J6 positions 1-2 installed (factory default) the filter is enabled and step pulses must have a minimum width of one microsecond. Pulses less than 0.5 microseconds in width will be rejected. With the filter disabled, Jumper J6 position 1-2 removed, step pulses must be a minimum of 0.25 microseconds wide. Therefore, the maximum step frequency is 500 KHz with the filter enabled and 2 MHz with the filter disabled.

---

## 3.2 Testing the Installation

---

**Background** The following procedure verifies that the 6410 is installed properly and that it was not damaged during shipment.

**Procedure** After installing the 6410 as described in Chapter 2, test your installation as follows.



**Warning**

*Perform this initial power up with the motor shaft disconnected from the load. Improper wiring or undiscovered shipping damage could result in undesired motor motion. Be prepared to remove power if excessive motion occurs.*

- Connections test**
1. Check all wiring and mounting to verify correct installation.
  2. With the power Off, check that S1 is set as follows (factory default settings):

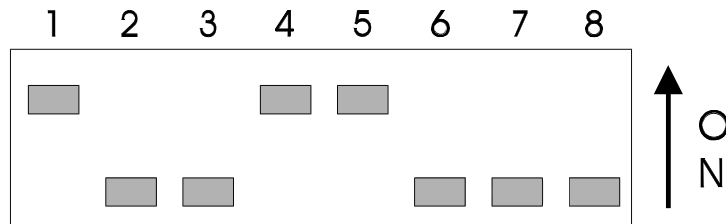

These settings reflect the following:

- Step size of 1/25
- Digital electronic damping enabled
- Idle current reduction enabled
- 5 A rms motor current

**Warning**

*If the motor is rated at less than 5 A rms winding current, set positions 6, 7, & 8 accordingly.*



Powering Up

---

## Procedure cont'd



### **Warning**

***Make sure power is removed before proceeding.***

3. Check that Jumper J6 is set as follows:

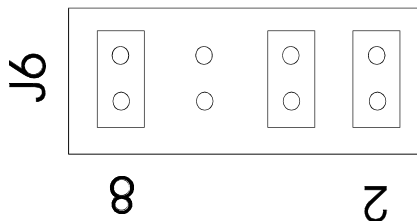

These settings reflect the following:

- Idle Current Reduction Enabled (0.1 second delay)
  - 6410 enabled without enable input driven
  - Decimal step size selected
  - Step input filter enabled
4. Switch On power.

---

## Signals test

1. Verify that the motor has holding torque by attempting to rotate the motor shaft. The energized motor shaft is either immovable or is resistant to rotation.
2. Input a step command and verify that the motor moves.
3. Reverse the polarity of the DIRECTION signal and step the motor. The direction of rotation should change.

---

## Getting help

If you need further assistance with your installation, please contact your local distributor.

---

## 4 Maintaining/Troubleshooting

---

**In this chapter** This chapter covers maintenance and troubleshooting of the 6410 unit.

### 4.1 Maintaining the 6410 Drive

---

**Introduction** The 6410 drives are designed for minimum maintenance. The following cleaning procedure, performed as needed, will minimize problems due to dust and dirt build-up.

---

**Procedure** Remove superficial dust and dirt from the unit using clean, dry, low-pressure air.

### 4.2 Troubleshooting the 6410 Drive

---

**Introduction** The 6410 has an “enabled” output which is on when the drive is enabled and off when the drive is disabled or faulted due to any of the following:

- Output overcurrent (line-to-line or line-to-neutral short)
- Bus overvoltage
- Low voltage supply out of tolerance.



---

Use the troubleshooting table and the simple circuit shown below to diagnose and correct most problems. If you are unable to achieve satisfactory operation, contact your local Pacific Scientific Distributor or the Applications Engineering Department.

**Simple circuit diagram**

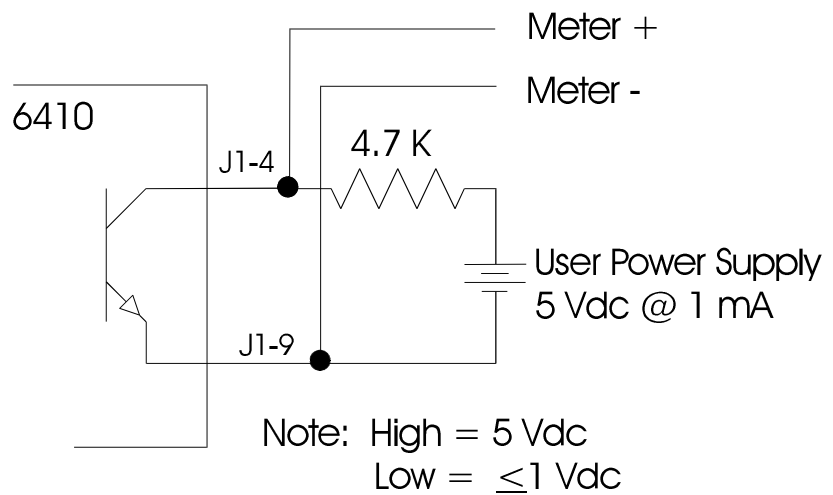

***IMPORTANT NOTE!***

*If you suspect that the 6410 drive has been damaged, DO NOT simply replace it with another and apply power. Re-check the power supply design and verify that it meets all requirements. Improper supply design is the most common cause for damaged drives.*



**Corrective action table**

<b>SYMPTOM</b>	<b>CORRECTIVE ACTION</b>
Motor produces no torque, Meter read high.	<p>Ensure that the J6 5-6 jumper is out, or if in, that the enable input opto is driven with at least 3 mA.</p> <p>Disconnect the motor cable and cycle the J2 power supply Off and On. If the meter reads low, check motor cable and motor for shorts across the windings or between the windings and the motor case.</p> <p>Check that the J2 power supply voltage is <math>\geq 24</math> Volts and <math>\leq 75</math> Vdc. If possible, check with an oscilloscope to verify that this is true on a transient basis.</p>
Motor produces no torque, meter reads low	<p>Verify that DIP Switch S1 position 6, 7, and 8 (current select) are set correctly.</p> <p>Re-check that the motor cable is wired correctly and properly plugged into the drive.</p>
Motor produces torque but does not turn.	<p>Make sure that the STEP input is switching and meets specified electrical and timing requirements.</p>
Motor rotates in the wrong direction	<p>Check polarity of the DIRECTION input. Also, check that the DIRECTION input satisfies the specified electrical and timing requirements.</p> <p>Reverse the A and <math>\bar{A}</math> motor phases.</p>
Motor does not reach expected position	<p>Check that the step size setting of the drive is the same as the step size setting of the indexer.</p> <p>Verify that the motor does not stall. If it does:</p> <ol style="list-style-type: none"> <li>1. Re-check sizing calculations. Be sure that the power supply voltage is high enough for the required torque vs. speed curve.</li> <li>2. Use a finer step size to avoid low-speed resonance problems.</li> <li>3. Enable Mid-Band Instability Compensation (S1 position 4 OFF).</li> </ol> <p>Check that the STEP and DIRECTION Inputs satisfy all electrical and timing requirements.</p>

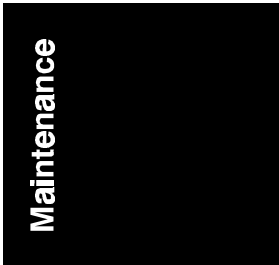

---

**If the drive is defective**

If you cannot correct the drive problem, or if it is defective, return it to Pacific Scientific for repair or replacement.

Return procedure

1. Call Pacific Scientific at (815) 226-3100 from 8am to 6pm Eastern Standard Time to get a Returned Materials Authorization Number (RMA#).

**Note:** *Do not attempt to return the 6410 or any other equipment without a valid RMA#. Returns received without a valid RMA# will not be accepted and will be returned to the sender.*

2. Pack the drive in its original shipping carton. Pacific Scientific is not responsible or liable for damage resulting from improper packaging or shipment.
3. Ship the drive to:

Pacific Scientific  
Motion Technology Division  
110 Fordham Road  
Wilmington, MA 01887  
Attn: Repair Department, RMA# \_\_\_\_\_

**Note:** *Do not ship Pacific Scientific motors to the above address. The correct address for motors is:*

Pacific Scientific  
Motor Products Division  
4301 Kishwaukee Street  
Rockford, IL 61105  
Attn: Stepper Repair Department, RMA# \_\_\_\_\_

***Shipment of your drive or motor to Pacific Scientific constitutes authorization to repair the unit.*** Refer to Pacific Scientific's repair policy for standard repair charges. Your repaired unit will be shipped via UPS Ground delivery. If another means of shipping is desired, please specify this at the time of receiving an RMA#.

---

# Appendix A Specifications

---

## Electrical

---

**Input power supply**      24 - 75 Vdc @ 5.0 Amps

<b>Rated drive current (motor phase current)</b>	<b>Setting</b>	
	5 A	5A ± 0.25A
	4.375	4.375 ± 0.2A
	3.75	3.75 ± 0.2 A
	3.125	3.125 ± 0.15 A
	2.5	2.5 ± 0.15 A
	1.875	1.875 ± 0.125
	1.25	1.25 ± 0.125
	0.625	0.625 ± 0.1 A

**Drive circuit**      Two-phase bipolar, chopper current regulated

**Chopper frequency**      20 KHz, nominal

<b>Step size</b>	<b>Switch settable</b>	<b>Steps/motor revolution (1.8° stepper motor)</b>
	Full (1/2)	200 (400)
	1/2 (1/4)	400 (800)
	1/5 (1/8)	1000 (1600)
	1/10 (1/16)	2000 (3200)
	1/25 (1/32)	5000 (6400)
	1/50 (1/64)	10000 (12800)
	1/125 (1/128)	25000 (25600)
	1/250 (1/256)	50000 (51200)

**Signal input requirements** (See circuit diagram, Section 2.5.3)

Optically Isolated Inputs:

<b>Input</b>	<b>Min Input Current - Opto ON</b>	<b>Max Input Current</b>	<b>Max Reverse Voltage (Input to J1-9)</b>
J1-1, J1-6 - Step	5.5 mA	10 mA	5 volts
J1-2, J1-7 - Direction	3.0 mA	4.5 mA	5 volts
J1-3, J1-7 - Enable	3.0 mA	4.5 mA	5 volts

**Signal output characteristics** (See circuit diagram, Section 2.5.3)

J1-4, J1-9 Enabled (Optically isolated NPN transistor with open collector and open emitter)

Maximum low level voltage while sinking 2 mA: 0.5 volts

---

**Maximum step rate**      2 MHz with step filter disabled  
500 KHz with step filter enabled

**Step/Direction timing requirements**      The figure below show the required timing relationship between the STEP and DIRECTION inputs:

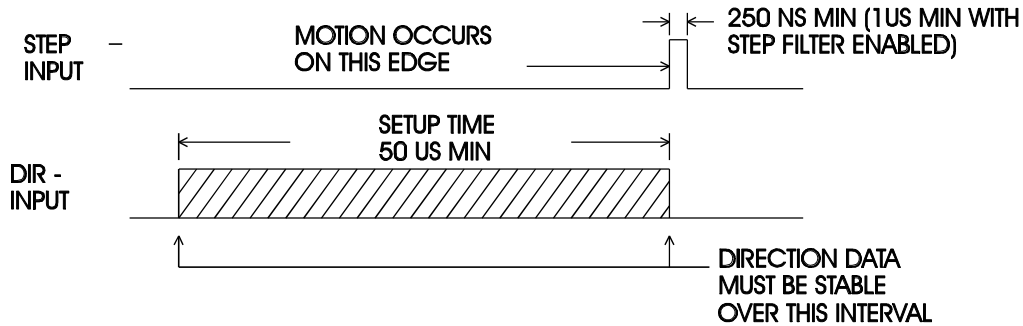

**Minimum ramp time for step rate (Accel/Decel)**      50 milliseconds (This restriction only applies with mid-band stability control circuit enabled).

**Drive state generator transition delay relative to input step**

1. With mid-band stability control circuit enabled, at pulse frequencies less than 500 full steps/sec, delay is less than 500  $\mu$ sec. At frequencies greater than 500 full steps/sec, delay is less than  $270^\circ$  of the input pulse period.
2. With mid-band stability control circuit disabled, delay is less than 10  $\mu$ sec at all step frequencies.

Specifications

---

## Environmental

---

**Operating Temperature** Full rated current 0 to 50° C ambient air with or without cover provided chassis properly mounted so as not to exceed 60° C.

**Storage temperature** -55° C to +70° C

**Maximum chassis temperature** 60° C

**Note:** *For optimal thermal performance, mount the 6410 chassis (back or side) to a cooling plate or heatsink. Use a thermal pad or grease if surface is irregular. A fan or idle current reduction may be employed to keep chassis below 60° C.*

**Humidity Range** 10 to 90%, non-condensing

**Convection Cooling** (6410 not mounted on cooling plate)

With optional heat sink Full rating (5 A) at 25° C Ambient  
2.5 A max at 45° C Ambient

Without heat sink 2.5 A max at 25° C Ambient  
1.25 A max at 45° C Ambient

See Figure 1 on the following page for plot of drive power dissipation vs. output current.



**Figure 1**

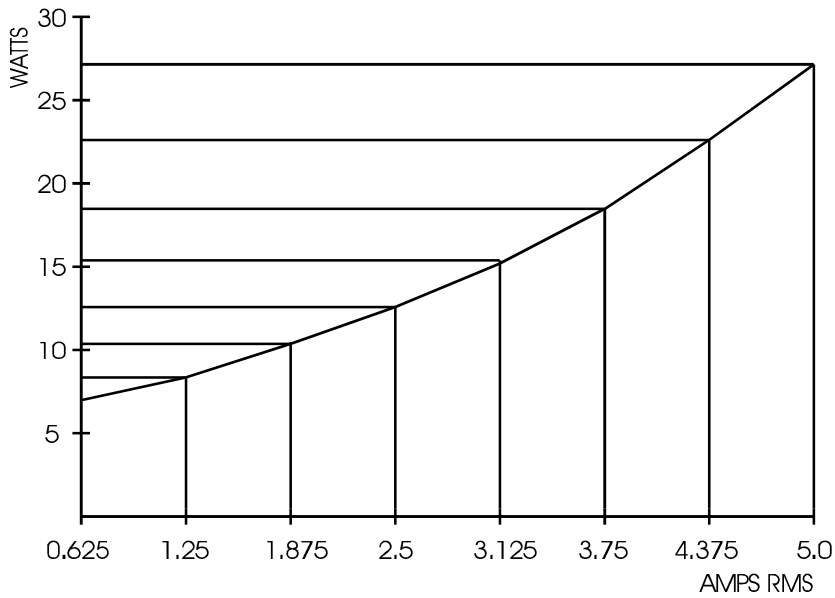

## Mechanical

**Dimensions** Refer to Section 2.4

**Weight** 1.0 lb nominal

### Connectors

- |              |  |
|--------------|--|
| Power Supply | PCD ELVH0310 connector. Mating connector: PCD ELVP03100.   |
| Signal       | 9 contact female D connector, Mating connector: ITT Cannon DE-9P with ITT Cannon DE110963 Hood and D20419 Clamp Kit. |
| Motor        | PCD ELVH0510 connector. Mating connector: PCD ELVP05100.   |

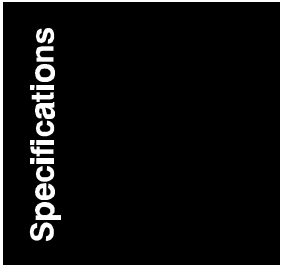





# Appendix B Ordering Information

**Background** This appendix lists 6410 part numbers and gives information on ordering.

6410 part number table

Part	Pacific Scientific Order #	Comment
Stepper Drive	6410	
Connector Kit	106-641000-01	9-pin D connector
		5-pin PCD
		3-pin PCD
Installation and Hardware Manual	MA6410	MA6410
Motor Cable	SPC-xxx-6410	xxx represents length in feet; for example, SPC-005 is a cable 5 feet long. For lengths over 50 feet contact Pacific Scientific. The connectors are MS on the motor end and PCD on the drive end to connect to Pacific Scientific motors.



---

<b>How to order</b>	Contact Pacific Scientific to order these parts.
Call	815-226-3100 from 8am to 6pm Eastern Standard Time.
Write	Pacific Scientific Customer Support 4301 Kishwaukee Street Rockford, IL 61105
Fax	(815) 226-3048

# Appendix C Power Supply Considerations

## C.1 Bridge, Capacitor Power Supply

The figure below shows the full-wave-bridge, capacitor-input configuration most commonly used to power one or more 6410 drive modules. A single transformer provides isolation and transforms the AC input voltage to a level that, when rectified, provides the desired DC bus voltage. Fusing should be between the rectifier and individual bus capacitors. This allows fuse size to be based upon the current requirements of a single module to provide the greatest protection. The capacitors must be connected to the 6410 DC+ and DC- inputs using twisted pairs no longer than three feet in length as shown to control winding inductive effects. A regen clamp to absorb power transferred from the motor to the 6410(s) is sometimes required. This section provides selection guidelines for the power supply components.

### Block diagram

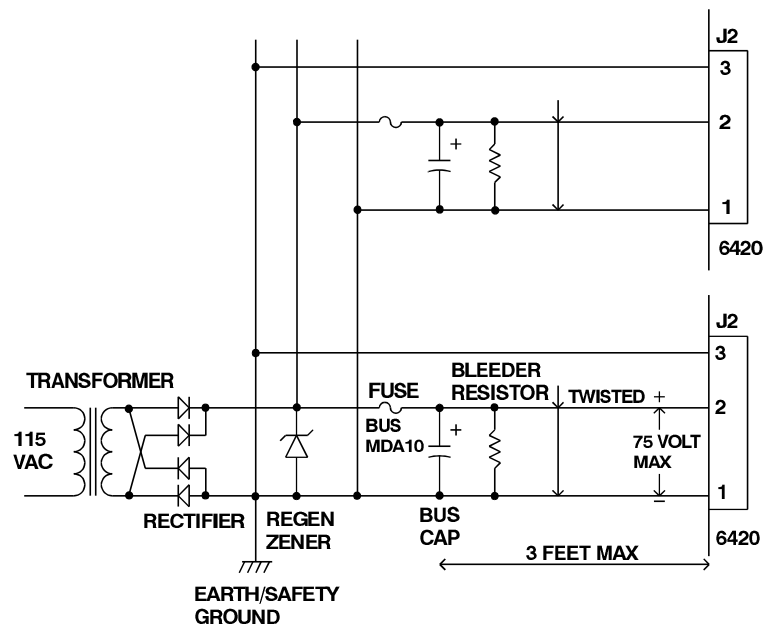



### **Warning**

*Power supply design must insure that the voltage between J2-2 and J2-1 never exceeds 75 volts under any operating conditions. These conditions include high line voltage, transformer regulation effects, voltage spiking due to current switching within the module and regeneration. Failure to do this can result in permanent damage to the 6410.*

## **C.1.1 Line Transformer Selection**

---

### **Primary voltage and frequency rating**

Make sure that the transformer is guaranteed to operate at the highest line voltage combined with the lowest line frequency that will ever be used to power your system. Failure to do so can result in saturation, large current increases and winding failure.

---

### **Secondary voltage rating**

Maximum motor speed performance will be achieved by using as high a motor supply voltage as possible without ever exceeding 75 volts. Of course lower voltages can also be used (so long as the voltage is greater than the minimum specified value of 24 volts) but motor torque will drop more rapidly as speed increases.

The peak bus voltage (excluding any spiking due to current switching in the drive module or any regeneration effects) is approximately equal to:

$$(1.414 * \text{Actual Secondary rms voltage}) - 1.5$$

**Note:** *This assumes a 0.75 volt drop across each rectifier diode. To insure this, as well as to discharge the bus capacitor when AC power is removed, it is recommended that a bleed resistor be placed across each bus capacitor as shown.*

---

### Example

If, for example, the secondary rms voltage is 40 Vac, the peak bus voltage will be  $1.414 * 40 - 1.5 = 55$  volts. A transformer with 115 Vac primary and 40 Vac secondary would produce 55 volts peak bus voltage under nominal line conditions and at rated loading.

However, if the line voltage increases 10% the peak bus voltage increases to:

$$(1.414 * 1.1 * 40) - 1.5 = 60.7 \text{ volts}$$

at rated transformer loading.

Load regulation must also be accounted for when selecting the transformer. Transformers are designed to produce their specified secondary voltage when loaded by their rated current. **For currents less than rated, the secondary voltage will increase.** Signal Transformer gives the following load regulation data for its line of rectifier transformers:<sup>1</sup>

VA Rating	Load Regulation
1 - 100	10%
100 - 350	8%
> 500	5% or less

This means that the secondary voltage of a 100 VA transformer will increase 10% over the specified voltage if the load current is reduced from rated current to zero. Since the stepper drive(s) might sometimes be disabled, the full regulation effect as well as maximum line voltage should be considered when selecting the transformer.

1 The VA product is obtained by multiplying the specified secondary voltage (Volts rms) by the rated secondary current (Amps rms). For example, a 24 Vac transformer with a rated secondary current of 1 Amp has a VA of 24.

---

Based upon these considerations, the table below gives the highest allowable rated secondary voltage when using a line with +10% voltage tolerance:

<b>Transformer VA Rating</b>	<b>Maximum Rated Secondary Voltage</b>
1 - 100	44.7 Vac
100 - 350	45.5 Vac
> 500	46.8 Vac

---

### Current Rating

The average current load of the 6410 is a function of the motor used as well as motor speed and torque. To optimize the power supply design, the supply current can be measured using a DC current meter when the motor is producing the highest shaft power. If it is difficult to make this measurement, assume the maximum average load current equals the selected phase current. Thus, if the DIP switch is set for 5 Amps RMS, assume the maximum average power supply current is 5 amps.

The average transformer secondary current equals the sum of the average currents for all 6410s powered by the supply. Because the transformer supplies pulses of current to charge the “bus” capacitor(s) on the other side of the diode bridge, the rms current is higher than the average current. The transformer should have a rated secondary rms current of at least 1.8 times the average current.

---

### Example

The transformer used to supply three 6410 drive modules, each set for 5 Amps rms should have a rated secondary rms current of  $1.8 * (5 + 5 + 5) = 27$  amps or greater.

**Note:** *It is generally not advisable to significantly oversize the transformer because this will increase rectifier surge current during turn on, as well as capacitor ripple current.*

---

## C.1.2 Rectifier Diode Selection

---

**Voltage rating** For the bridge rectifier configuration shown, the peak inverse voltage (PIV) equals 1.414 times the secondary rms voltage. For example, a 40 Vrms secondary will develop  $1.414 * 40 = 56.6$  PIV across the rectifier diodes. To allow for line variation and spiking, allow at least a 50% safety factor in the diode rating. Therefore, **the PIV rating of the rectifier diodes should be at least twice the rated secondary rms voltage.**

---

**Current Rating** Since each diode conducts only on alternate cycles, the average diode current will be half the supply's average DC current load on the supply. When power is first applied, there is a surge of current to charge the capacitor(s) which must be less than the diode's peak one cycle surge current ( $I_{FSM}$ ) rating. Typically, diodes are chosen with an average current rating of at least twice the average current load of the supply. It is often advisable to select diodes with an even greater average current rating because they have lower thermal resistance between junction and case and hence ease heat sinking requirements. It is good design practice to limit the maximum junction temperature to 125°C. Testing should be done to insure the power-on surge current is within the diode's  $I_{FSM}$  rating.



---

### C.1.3 Capacitor Selection

---

The table below gives the minimum bus capacitance value for a single 6410 as a function of the current setting and bus voltage. These values give approximately 10% peak-to-peak ripple voltage with a 60 Hz line (increase capacitor values by 20% for use with a 50 Hz line).

<b>Current Setting</b>	<b>30 Volt Bus</b>	<b>50 Volt Bus</b>	<b>70 Volt Bus</b>
5.0	14,000	8300	6000
4.375	12,000	7300	5200
3.75	10,000	6300	4500
3.125	8700	5200	3700
2.5	6900	4200	3000
1.875	5200	3100	2200
1.25	3500	2100	1500
0.625	1700	1000	740

Bus Capacitance in Micro farads

---

#### Ripple current rating

The bus capacitor's 120 Hz ripple current rating should equal or exceed the 6410's current setting. The capacitor's working voltage rating must exceed the maximum bus voltage under all line, load, and regen conditions. Select a capacitor rated for at least 1.3 times the nominal bus voltage.

#### Example

Suppose a 6410 is operating at 70 volts and is set for 5 A rms motor current. Assuming a 60 Hz line, a bus capacitor of 6000 micro farads should be used. The capacitor should have a 120 Hz ripple current rating of at least 5 amps rms and a working voltage of at least  $1.3 * 70 = 91$  volts.

The bus capacitor should be connected to the 6410 using a twisted pair, no longer than 3 feet in length.

---

## C.1.4 Fuse Selection

---

The BUS MDA 10 slow blow fuse or equivalent is recommended when the 6410 is set for 5 Amps. Fuses from the same family but with proportionally lower current rating can be used with lower current settings.

## C.1.5 Regeneration Considerations

---

The motor power supply voltage can be “pumped up” when the motor and load are decelerated by the drive. In effect, the motor becomes a generator converting mechanical energy stored in the spinning motor and load inertia into electrical energy. If the mechanical energy is less than the losses in the drive and motor, the supply voltage does not increase. If the mechanical energy is greater than these losses, the supply voltage will increase (be pumped up).

The mechanical energy of a spinning inertia is given by:

$$E = 3.87 * 10^{-5} * J * S^2$$

where: E = kinetic energy (joules)

J = inertia in oz-in-sec<sup>2</sup>

S = speed in rpm

---

### Final voltage

If this energy is converted to electrical energy in the form of charge on the bus capacitor(s), the voltage will be:

$$V = \sqrt{V_o^2 + \frac{2E}{C}}$$

where: V is the final voltage (after energy transferred to capacitor(s))

V<sub>o</sub> is the initial voltage

C is the total capacitance in farads

E is the initial kinetic energy in joules

---

### Example

If an unloaded E34 motor (rotor inertia = .035 oz-in-sec<sup>2</sup>) is rotating at 1500 rpm, the stored energy is:

$$3.87 * 10^{-5} * .035 * 1500^2 = 3.0 \text{ joules}$$

If all this energy is transferred to a 6800 mf capacitor, initially charged to 70 volts, the voltage on the capacitor after the transfer is equal to 76 volts.

**Note:** *This exceeds the volt maximum specification of the 6410 drive.*

In practice, most or all the kinetic energy is dissipated in the motor windings or in the drive power circuitry so that voltage pump-up is often not a problem. However, in systems running at high speeds and having large load inertia, the voltage might be pumped up significantly and circuitry must be added to insure that the 75 volt limit is never exceeded.

**Note:** *Regeneration effects should be considered in the presence of high line conditions.*

To find out if regenerative energy is a problem, run the system while monitoring the supply voltage with a storage oscilloscope. Alternatively, a simple peak detector made from a diode and a capacitor can be attached to the bus and the peak voltage measured using a digital voltmeter. Start the system with slow deceleration rates and monitor the motor power supply to see if the voltage rises during deceleration. Slowly increase the deceleration rate (shorten the deceleration time) while monitoring the voltage. If regeneration causes the supply voltage to exceed 75 Vdc peak, a clamping circuit is required.

**Note:** *Be sure to consider the effect of high line voltage when evaluating this test.*

## Clamping Circuit

If a clamp is required, a power zener diode can be used as shown in the figure. The maximum zener clamp voltage must not exceed 75 volts.

### Caution

*If a clamp is required, the transformer secondary voltage must be re-checked to insure that the minimum clamp voltage is not exceeded under high line and low load conditions when there is no regeneration. Otherwise, the zener might overheat and fail.*

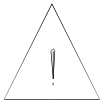

To determine the required diode power rating, start with a 5W device and monitor the zener current with a current probe. Power (in watts) is the average current (in amps) times the zener voltage. Estimate the average current from the oscilloscope trace and compute the power. Select a zener rated slightly higher than the measured power.

If the average power is too high to be conveniently dissipated in a zener diode, the active voltage clamp circuit shown below can be used instead. Power is dissipated in the 25Ω, 30W resistor if the Motor Power Supply voltage exceeds 75 volts.

## Active clamp circuit

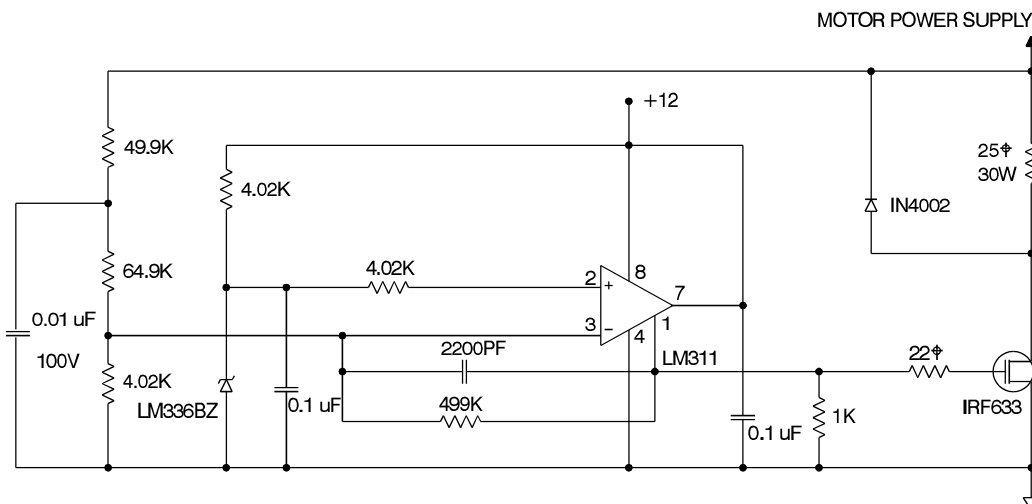

---

## C.2 Powering the 6410 from a Regulated Supply

---

Certain precautions should be taken when powering the 6410 drive from a regulated power supply. The 6410's bipolar chopper output stage draws current from the DC supply in the form of pulses with fast rise and fall times. This may be a problem for some regulated supplies designed to drive loads having relatively constant or slowly varying current drain. If a regulated supply is used and problems are encountered, a 470uF capacitor should be placed across the DC+ and DC-lines between the power supply and 6410. Ideally this capacitor is located close to the 6410 drive but it can be located near the power supply and connected to the 6410 with a twisted pair no longer than 3 feet in length. The capacitor should have a 20KHz ripple current rating of at least the 6410's current setting and a voltage rating of 1.3 times the nominal bus voltage.

A second precaution involves regenerated power (see section C.1.5). Regulated supplies are usually not designed to absorb power. This might cause their output voltage to rise during regeneration and lead to power supply and/or 6410 damage. The same considerations and solutions described in section C.1.5 apply.

**6410(s) powered by regulated supply**

The figure below illustrates powering the 6410 from a regulated supply where both an external capacitor and regenerated power dump circuit are required. The recommended fusing is also shown.

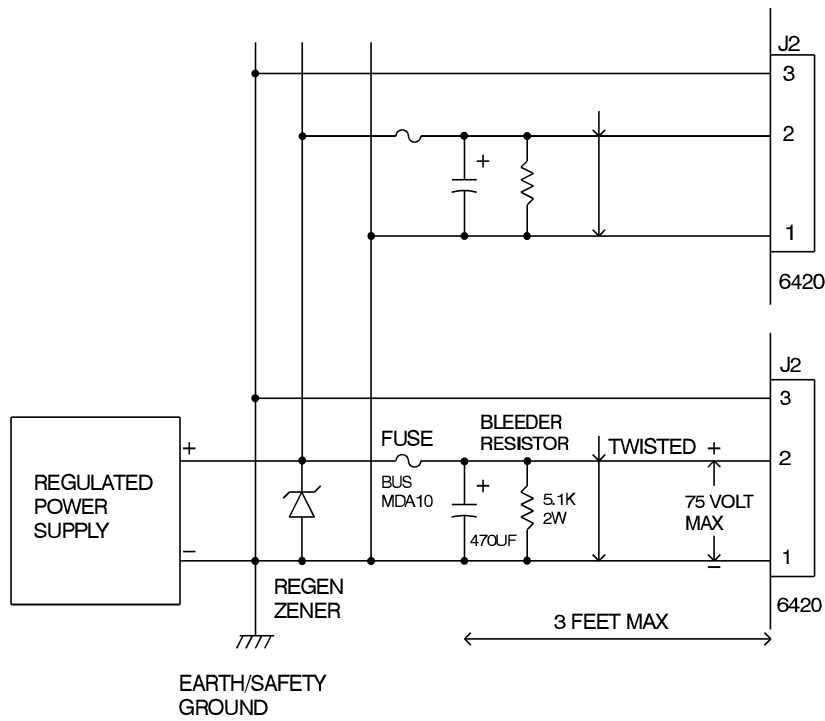



---

# Appendix D CE Installation Guide

---

## Introduction

The information contained in this appendix applies to the 6410 ONLY. The 6410 is designed for use within machines that require compliance with European Safety and EMC Directives. The standards that the 6410 complies with are described in the Declaration of Conformity on the following page.

**Note:** *The information contained in this appendix supplements the material in the MA6410.*

---

## Customer Responsibility

This appendix, supplied with all 6410 series drives, provides detailed information on installation. This appendix must be closely followed if EMC compliance is to be maintained. It covers details such as mechanical mounting, safety earth connections and motor wiring.

The 6410's input voltage is provided by a user supplied dc power supply. System harmonics and conducted emissions are dependent on the system chosen. Therefore, the machine builder is responsible to properly filter the installation thereby preventing unwanted conducted line noise.

EN 61800-3 also puts the responsibility of filtering on the machine builder. For additional information please see the "Assessment of Compatibility" section in EN 61800-3.



---

**CE Declaration of Conformity**

Pacific Scientific  
Motion Technology Division  
110 Fordham Road  
Wilmington, MA 01887 USA

This is to certify that:

Declares that the product(s):	
Designation	<i>STEPPER DRIVE</i>
Type	<i>6410, 6415, 6420</i>

comply with the following relevant regulations:	
CE Guideline	<i>89/336/EEC</i> <span style="float: right;"><i>EMC Directive</i></span>
Applied harmonized standards:	EN 61800-3: 19956

Manufacturer's Contact:	Peter Deneault Compliance Engineer
-------------------------	---------------------------------------

Issued By:	Pacific Scientific, Motion Technology Division President, William T. Fejes
Place, Date:	Wilmington, MA, USA, 10-29-98

Legally binding  
Signature

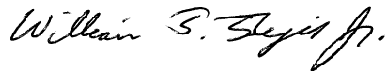

---

**CE Test Set Up** The 6420 was determined to be the noisiest configuration for the 64xx family. Therefore it was used for all EMC testing.

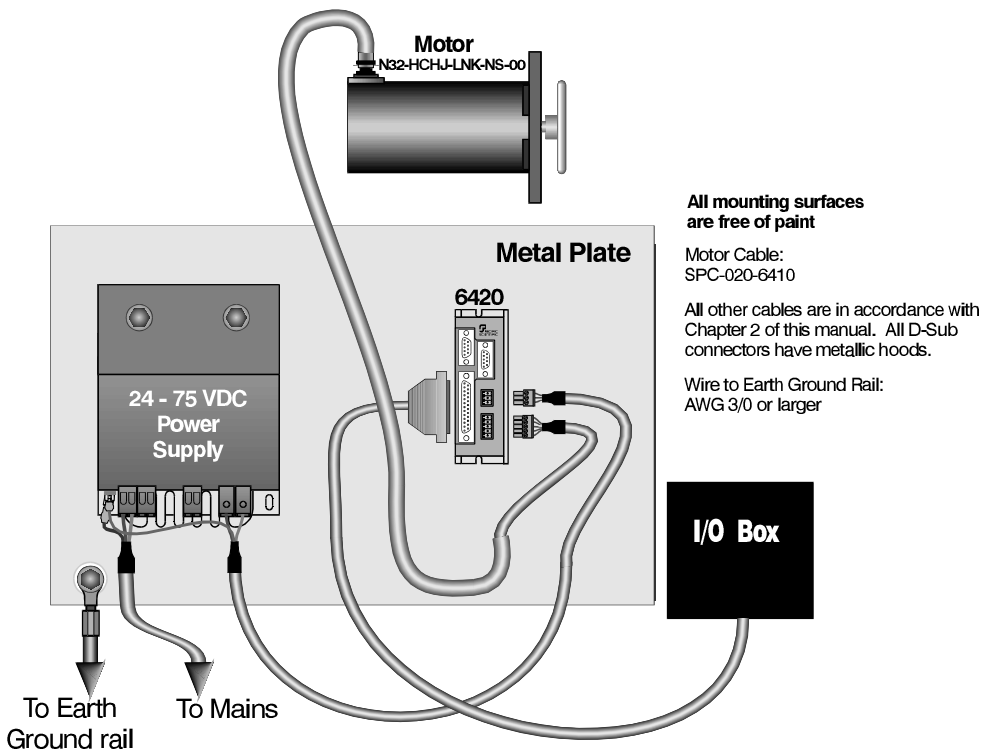

---

**Safety**

In addition to the safety guidelines given in Section 2.2, observe the following:

- Electronic drives contain electrostatic sensitive devices which can be damaged when handled improperly. Qualified personnel must follow ESD protection measures. For example: wear grounded heel and wrist straps when contacting drive.
- Follow IEC 536-2 and IEC 1140 for installation protection against electric shock.
- Installation shall be performed in accordance with local electric codes, local accident prevention rules, and EN 61800-3.
- All covers shall be closed during operation.
- Braided cable shields should be connected to protective earth ground.

**Drive mounting**

Mount the drive to a conductive surface of the machine chassis, to ensure a good high frequency ground. If the chassis is painted or coated with another nonconductive coating, remove the coating from the mounting location prior to mounting the drive.

**Cable Routing**

To avoid the risk of crosstalk, motor and command I/O cables should be kept away from sensitive signal cables such as telephone and intercommunication lines.

---

## Cable shielding and grounding

The following information is not required for CE compliance of a single axis installation. When planning a multi-axis installation, or if extra high frequency noise reduction is required, Pacific Scientific suggests:

- In addition to the cable requirements given in this manual the motor and signal interface cables should have a braided shield which can be grounded to reduce high frequency disturbances.
- The motor cable shield must be grounded near the drive with a suitable high frequency ground. Such a ground connection is made by removing the cable's outer insulation, to expose the braided shield, then clamping the exposed braid to a conductive surface of the machine chassis. If the chassis is painted or coated with another nonconductive coating, remove the coating from the clamping location prior to clamping the shield. It is important that the clamp chosen be conductive and provide a full 360 degree connection.

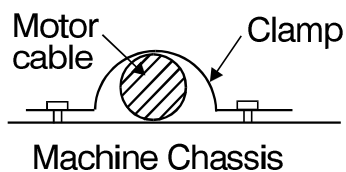
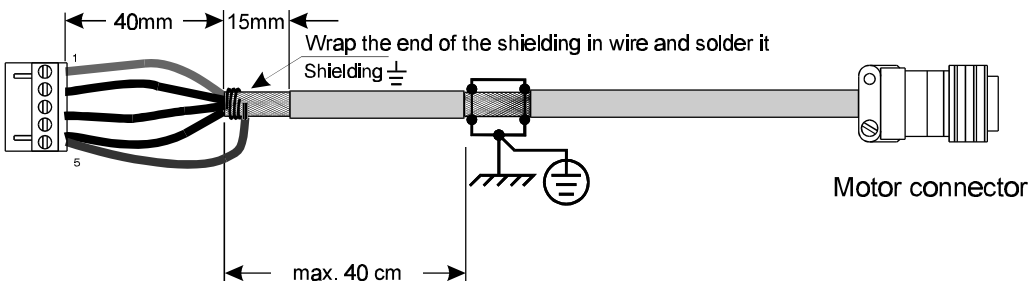

**Note:** Ground shield to machine chassis with a metal clamp providing a 360 degree termination cable.

---

The signal interface cable shield should be grounded to the drive through the 9 pin D-sub connector's conductive hood. If the cable connector does not provide a 360 degree ground connection to the shield, the signal interface cable should be grounded in accordance with the instructions given in the previous paragraph for the motor cable.

For additional information please contact the factory to request:

- Application Note 106 - Reducing Motor Drive Line Noise
- Application Note 107 - Reducing Motor Drive Radiated Emissions.

## Connection Diagram

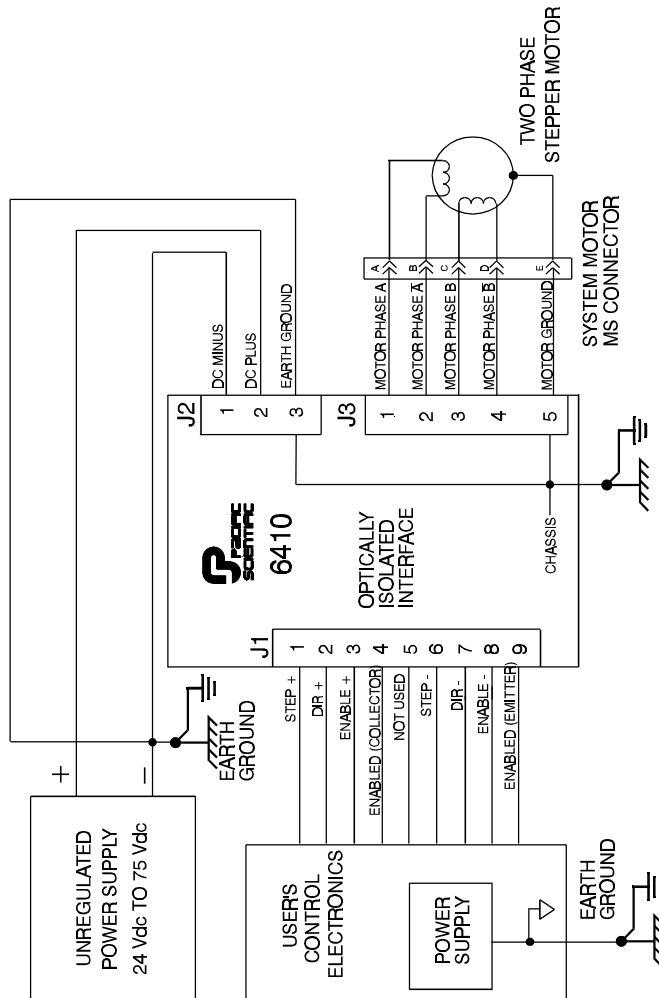



# Index

---

## A

Address , 4-4, B-2  
Applications, 1-4

## B

Bipolar chopper drive, 1-2

## C

Cable  
  CE, D-5  
  J3, 2-12  
  J2, 2-19  
Capacitor,  
  external, 2-17,  
  motor selection, C-6  
Chopper frequency, A-1  
CE installation, D-1  
  test set up, D-3  
Clamping circuit, C-9  
Cleaning unit, 4-1  
Components, system, 1-4, 2-3  
Connections  
  motor, 2-9  
  parallel, 2-13, 2-14, 2-15, 2-16  
  series, 2-13, 2-14, 2-15, 2-16  
  testing, 3-7  
Connectors, A-5  
  J3, 2-11  
  J1, 2-23

Current,  
  input, 2-3  
  motor, C-4  
  output, 1-1  
  rating, A-1, C-4, C-5

## D

Damage, 2-1  
Date code, 2-1  
Declaration of Conformity, D-2  
Defective unit, 4-4  
Definition, general drive, 1-1  
Digital electronic damping, 1-2, 3-4  
  benefits, 3-4  
  definition, 3-4  
Dimensions, 2-6  
Diode, selection, C-5  
DIRECTION  
  input, 2-20, 4-3, A-2  
Drive  
  circuit, A-1  
  current/stepsize, see S1 switch  
  features, 1-2



## **E**

- Earth ground, safety, 2-2
- Enabling the drive, 3-7
- External capacitor, 2-17

## **F**

- Fuse selection, C-7

## **G**

- Getting help, 3-8
- Grounding, D-5

## **H**

- Help, getting, 3-8
- Holding torque and  
idle current reduction, 4-3
- Humidity, A-4

## **I**

- ICR, see Idle current reduction
- Idle current reduction, 1-3, 3-5
  - benefits, 3-5
  - definition, 3-5
- Input/Output
  - connections diagram, 2-8
- Inputs, 2-7
- Inspecting, 2-1
- Installation, 2-2, 2-4
- Interface,
  - high voltage, 2-23
  - typical, 2-21

## **J**

- J3-Motor, 2-9
  - cable, making your own, 2-11
  - connector, 2-11
  - diagram, 2-12
  - PacSci, cable, 2-9
  - procedure, 2-12
  - safety, 2-2
  - table, 2-11
- J2-Power, 2-17
  - cable, 2-19
  - diagram, 2-18
  - procedure, 2-19
  - table, 2-17
- J1-Signal interface, 2-19
  - connector, 2-24
  - diagram, 2-22
  - I/O table, 2-20

## **L**

- Line transformer, selection, C-2

## **M**

- Maintenance, 4-1
- Manual, how to use, 1-4
- Microstepping, 1-2, 3-3

Motor, 2-3  
cable, making your own, 2-11  
connector, 2-11  
    Flying Lead, 2-13  
    MS connectors, 2-15  
    Power Max, 2-16  
    Terminal Board, 2-14  
PacSci, cable, 2-9  
selection, 2-3  
Mounting, 2-4  
    CE, D-4  
    dimensions, 2-6, D-8  
    guidelines, 2-7  
Multi-axis, 2-3

## N

Noise pickup reduction, 2-9

## O

Optically isolated connections, A-2  
    safety, 2-2  
Opto supply table, 2-23  
Order information, B-1  
Overview, general, 1-1

## P

Packing list, 2-1  
Parallel connection, 2-13 - 2-16  
Phase A,  $\bar{A}$ , 2-11  
Phase B,  $\bar{B}$ , 2-11  
Power supply, considerations, C-1  
    Motor, 2-17, C-1  
Power-up, 3-1

Problems/Solutions, 4-2

## R

Ramp time, A-3  
Rectifier diode, selection, C-5  
Regeneration, C-7  
Regulated supply, C-10  
Repair procedure, 4-4  
Return, procedure, 4-4

## S

S1 switch  
    location, 3-2  
    setting, 3-2  
    digital electronic damping  
        set up, 3-4  
    idle current reduction, setup, 3-5  
    step size set up, 3-3  
Safety, 2-2, D-4  
Series connection, 2-13 - 2-16  
Shock hazard, reduction, 2-9  
Short circuit protection, circuitry, 1-2  
Signal interface - J1  
    connector, 2-23  
    high voltage, 2-23  
    input/output table, 2-20  
    interface diagram, 2-22  
    opto supply, 2-23  
    requirements, A-2  
Specifications, A-1  
STEP, input, 2-20  
Step rate, A-3

- Step size set up, 3-3
  - benefits, 3-3
  - definition, 3-3
- Step size, 1-3, A-2
- Storage, 2-1
- System
  - components, 1-4
  - diagram, 1-5, 2-8

## T

- Temperature
  - operating, 2-4, A-4
  - storage, 2-1, A-4
- Testing, 3-7
  - connections, 3-7
  - procedure, 3-7
  - signals, 3-8
- Troubleshooting, 4-1

## U

- Unpacking, 2-1

## V

- Ventilation, 2-7
- Voltage,
  - motor supply, 1-1, 2-17, A-1, C-1

## W

- Warranty, 1-5
- Weight, 2-7, A-5